

Control Theory

Second Edition
JR Leigh

The Institution of Electrical Engineers

Published by: The Institution of Electrical Engineers, London,
United Kingdom

© 2004: The Institution of Electrical Engineers

This publication is copyright under the Berne Convention and the Universal Copyright Convention. All rights reserved. Apart from any fair dealing for the purposes of research or private study, or criticism or review, as permitted under the Copyright, Designs and Patents Act, 1988, this publication may be reproduced, stored or transmitted, in any forms or by any means, only with the prior permission in writing of the publishers, or in the case of reprographic reproduction in accordance with the terms of licences issued by the Copyright Licensing Agency. Inquiries concerning reproduction outside those terms should be sent to the publishers at the undermentioned address:

The Institution of Electrical Engineers,
Michael Faraday House,
Six Hills Way, Stevenage,
Herts., SG1 2AY, United Kingdom

www.iee.org

While the author and the publishers believe that the information and guidance given in this work are correct, all parties must rely upon their own skill and judgment when making use of them. Neither the author nor the publishers assume any liability to anyone for any loss or damage caused by any error or omission in the work, whether such error or omission is the result of negligence or any other cause. Any and all such liability is disclaimed.

The moral right of the author to be identified as author of this work has been asserted by him in accordance with the Copyright, Designs and Patents Act 1988.

British Library Cataloguing in Publication Data

Leigh, J. R. (James Ronald), 1931-
Control theory : a guided tour. - 2nd ed.
1. Control theory 2. Automatic control
I. Title
629.8'312

ISBN 0 86341 332 3 (hardback)
ISBN 0 86341 339 0 (paperback)

Typeset in India by Newgen Imaging Systems (P) Ltd., Chennai
Printed in England by MPG Books Ltd., Bodmin, Cornwall

To the colleagues who have enriched my professional life

Introduction to the second edition

In the ten years that have passed since the first edition of this book was published, the main developments in the subject of control have been:

- Within control theory proper, the rise of H_∞ and similar approaches, allowing a combination of practicality, rigour and user interaction to be brought to bear on complex control problems and helping to close the often discussed gap between control theory and practice.
- The rise of artificial intelligence (AI) techniques such as a neural networks that, within a computer intensive context, have become inextricably linked into the control subject.
- The rise in the availability of comprehensive software packages particularly designed for solving control related problems.

In this new edition, I have added two additional chapters devoted to H_∞ approaches and to AI approaches, respectively. I have also added a chapter that, placed at the end of the book, briefly reviews the development of control, so forming something of a context for what has gone before.

In addition to these major changes, I have reviewed and, where necessary, revised all the earlier material. In the spirit of the first edition, I have added ten additional diversionary 'Interludes' and of course taken the opportunity to update and enhance the references and suggestions for further reading. I very much hope that the resulting new edition is well placed to satisfy the aims of the first edition, which were as stated in the following section.

The structure, content and purpose of the book

This book is drastically different from other control books. It follows no well-trying formula but, thinking as it goes, imitates in a sense the author's discussions with students, supervisees and colleagues. Most of these discussions were interesting because they were concerned with concepts too general or too simple to be included in standard textbook material or alternatively they were too detailed, esoteric or unfinished to be there.

The book is structured around a few limited concepts that are central to control theory. The concepts are presented with a minimum of detail and, once sufficient work has been done to establish ideas, the reader is pointed off to specific references.

The treatment is augmented by more detailed interludes. These interludes appear in a different typescript and although they are always relevant to their context, they are not necessarily so easy to follow as the mainstream text. However, if they are skipped over, this will not be detrimental to understanding the main thread of the book.

The first three chapters, quite deliberately, contain no mathematics at all. It is intended that these chapters can form a useful introduction to control theory for a wide class of readers. These chapters largely answer the questions:

- What is control theory?
- What are the main ideas?
- What are the features that make the subject so fascinating and absorbing?

The features of the book may be summarised:

- Emphasis on concepts.
- Follow up for the reader by reference links from the text to easily available standard books.
- The first three chapters are entirely non-mathematical.
- The large number of interludes stimulates interest. Appearing in a distinctive typescript, they may be omitted without detriment in a first reading of the mainstream text.
- Very extensive annotated bibliography.

The policy for citation of references within this book is worthy of explanation:

Control is, in general, an integrated rather than disparate subject. Many of the references cited in this text are relevant to a number of different sections and chapters of the book and, on this basis, it is appropriate that references are cited as part of the whole work rather than by individual chapter. A complete list of references is therefore given in Chapter 19. However, the reader will also note that Chapters 8, 16 and 17 contain references that are not only of general use, but are of primary importance to the chapter in which they appear.

The intended readership for the book is:

- Students working at any level on control engineering. Despite the multiplicity of available control books at all levels, students still struggle to understand basic concepts. This book is intended as their companion and friend.
- Students of science, computing, mathematics and management. The book will supply these students with the main concepts of control, thus supporting the auxiliary control courses that are attended by these students.
- Industrialists, managers and professionals in a wide variety of fields. A large number of professionals from a wide variety of fields wish to understand the fundamentals and the potential of control, to an extent that will demystify the subject and that will allow them more effectively to assess the benefits of control to their particular areas.
- Engineers already familiar with control. They could actually find the book enjoyable, paralleling the enjoyment that I have obtained from writing it.

Every worthwhile discipline has a strong structure and underlying principles and is possessed of a continuous striving towards improved coherence so that what, at first sight, appeared to be isolated phenomena take their place in the structure in a consistent way. Thus, the science of physics has been brought, by generations of dedicated development, to its present well-unified state.

Here, we are concerned with the structure, principles and context of control theory.

Control theory is a very powerful body of knowledge indeed. It allows the synthesis of systems having specified characteristics. It can model and include within its control loops any complex object (for instance, an aircraft) that needs to be so included. It can produce adaptive solutions that change automatically as circumstances change. It can combine with pattern recognition, with expert systems and with artificial intelligence (AI) in general. It makes use of computer power to identify problems, to solve problems, to validate solutions and to implement the final solutions. Control has an impressive track record of successful applications across aircraft, ships, satellite and missile guidance, process industries (chemicals, oil, steel, cement, etc.), pharmaceuticals, domestic and computer goods (automatic cameras, etc.), public utilities (e.g. all aspects of electrical generation and supply), automatic assembly, robotics, prosthetics and increasingly it lends its basic ideas to other disciplines.

Control theory is built up around a few very simple ideas: such ideas as feedback loop and stability. The writing of this book has been motivated by a belief that it is

absolutely vital to obtain a robust understanding of these few simple ideas and not allow them to be submerged below a cloud of techniques or numerical detail.

Acknowledgments

I would like to thank the following for their help and guidance:

- Dr Glen Vinnicombe, for permission to adapt examples and material from his book (Vinnicombe, 2002), for use in Section 16.7 on the ν gap metric.
- Professor Derek Atherton for his many helpful suggestions when the book was at the manuscript stage.
- The editorial and production staff at the Institution of Electrical Engineers, for their helpfulness and professionalism.

Contents

Introduction to the second edition	xvii
The structure, content and purpose of the book	xix
1 Control concepts: a non-mathematical introduction	1
1.1 General systems ideas	1
1.2 What is control theory? – an initial discussion	3
1.3 What is automatic control?	6
1.4 Some examples of control systems	8
2 Control design ideas: a non-mathematical treatment	11
2.1 Initial discussion	11
2.2 Question: Can the best possible control actions be synthesised by some mechanism?	12
2.3 Requirements for an automatic control system	12
2.4 Automatic feedback control	14
2.5 Diagrams illustrating and amplifying some of the concepts described so far and showing relationships to a software engineering context	14
3 Synthesis of automatic feedback control loops: a more quantitative view	19
3.1 Feedback loops: further discussion	19
3.2 What sorts of control laws are there?	21
3.3 How feedback control works – a practical view	22
3.4 General conditions for the success of feedback control strategies	27
3.5 Alternatives to feedback control	28

4	How the Laplace transform greatly simplifies system representation and manipulation	29
4.1	Laplace transform techniques	29
4.2	Definition of the Laplace transform	29
4A	<i>Convergence of the integral that defines the Laplace transform</i>	30
4B	<i>Problems with 0^- and 0^+</i>	31
4.3	Use of the Laplace transform in control theory	31
4.4	The concept of transfer function	32
4.5	System simplification through block manipulation	32
4.6	How a transfer function can be obtained from a differential equation	33
4.7	Poles and zeros of a transfer function	34
4.8	Understanding system behaviour from a knowledge of pole and zero locations in the complex plane	34
4.9	Pole placement: synthesis of a controller to place the closed loop poles in desirable positions	38
4.10	Moving the poles of a closed loop system to desirable locations – the root locus technique	39
4.11	Obtaining the transfer function of a process from either a frequency response curve or a transient response curve	40
4C	<i>Convolution – what it is</i>	41
4.12	Determination of transfer functions by cross-correlation	43
4D	<i>Calculation of resonant frequencies from the pole–zero diagram</i>	43
4E	<i>Derivation of a formula for damped natural frequency</i>	45
4F	<i>The root locus of a system with open-loop poles and zeros located as in Figure 4.19 will include a circle centred on the zero</i>	46
5	Frequency response methods	47
5.1	Introduction	47
5.2	Design using frequency response methods – initial explanation	47
5.3	Frequency response of a linear system	48
5.4	The Bode diagram	48
5.5	Frequency response and stability: an important idea	49
5.6	Simple example of the use of the foregoing idea in feedback loop design	50
5.7	Practical point – the need for stability margins	51
5.8	General idea of control design using frequency response methods	51
5.9	Obtaining the frequency response of a system experimentally – a list of difficulties	52

5.10	Design based on knowledge of the response of a system to a unit step input	52
5.11	How frequency response is obtained by calculation from a differential equation	53
5.12	Frequency response testing can give a good estimate of a system's transfer function	55
5.13	Frequency response of a second order system	56
5A	<i>The frequency response of a system with poles and/or zeros near to the imaginary axis</i>	58
5B	<i>Some interesting and useful ideas that were originated by Bode</i>	58
5.14	Nyquist diagram and Nichols chart	60
6	Mathematical modelling	61
6.1	Approaches to mathematical modelling	61
6.2	Methods for the development of mathematical models	62
6.3	Modelling a system that exists, based on data obtained by experimentation	62
6.4	Construction of models from theoretical considerations	64
6.5	Methods/approaches/techniques for parameter estimation	64
6.6	Why modelling is difficult – an important discussion	66
6.7	Fixing of parameters	67
6.8	Parameter estimation	67
6.9	Regression analysis	67
6.10	Analysis of residuals	68
6A	<i>Doubt and certainty</i>	68
6B	<i>Anticipatory systems</i>	70
6C	<i>Chaos</i>	71
6D	<i>Mathematical modelling – some philosophical comments</i>	73
6E	<i>A still relevant illustration of the difficulty of mathematical modelling: the long march towards developing a quantitative understanding of the humble water wheel, 1590–1841</i>	76
6F	<i>A postscript on the effectiveness of thought experiments</i>	79
6G	<i>Experimentation on plants to assist in model development – the tests that you need may not be in the textbook!</i>	79
7	Limits to performance	83
7.1	Stability – initial discussion	83
7A	<i>Stability theory – a long term thread that binds</i>	84
7.2	Stability for control systems – how it is quantified	86
7B	<i>The ingenious method of Hurwitz</i>	88
7.3	Linear system stability tests	88
7.4	Stability margin	88
7.5	Stability tests for non-linear systems	89

7.6	Local and global stability	90
7.7	Lyapunov's second (direct) method for stability determination	91
7C	<i>Geometric interpretation of Lyapunov's second method</i>	92
7.8	What sets the limits on the control performance?	94
7.9	How robust against changes in the process is a moderately ambitious control loop?	96
7.10	Limits and constraints on synthesis: summary of points	98
7.11	Systems that are difficult to control: unstable systems	98
7D	<i>Cancellation of an unstable pole by a matching zero in the controller</i>	99
7E	<i>Shifting an unstable pole by feedback</i>	100
7.12	Systems that are difficult to control – non-minimum phase systems	101
7.13	Some interesting theoretical limitations on performance	102
	7.13.1 Sensitivity functions and their interrelation	102
7F	<i>Motivation for the name: non-minimum phase systems</i>	103
	7.13.2 Integral constraints in the time domain	104
	7.13.3 Design constraints caused by Bode's theorem	105
7G	<i>Mapping of complex functions – a few points that underlie classical control theory</i>	106
7H	<i>Derivatives of a complex function $G(s)$</i>	108
7I	<i>Singularities of a complex function $G(s)$</i>	108
8	Some practical aspects of control design, justification and implementation	111
8.1	How efficient is it to control an unknown process by a controller that consists only of a high gain of value C that in the limit becomes a relay controller?	111
8.2	An off-the-shelf approach to the control of an unknown process	113
	8.2.1 The three-term controller	113
	8.2.2 Illustration of the value of an integral term in removing any constant error	113
	8.2.3 Illustration of the value of a derivative term to control the degree of damping	114
	8.2.4 How can the three coefficients of a three-term controller be chosen quickly in practice	114
8A	<i>How to learn something from the first part of a step response</i>	120
8B	<i>New York to San Francisco telephony – an early illustration of the spectacular success of feedback in achieving high-fidelity amplifications of signals</i>	122
8.3	Converting a user's requirements into a control specification	123

8.4	Methodologies for deciding the scope and attributes of automatic control schemes for industrial application (methodologies for economic justification of investment in automation)	124
8.4.1	Methodologies and illustrations	124
8.5	References on methodologies for economic justification of investment in automation	130
9	Linearisation	131
9.1	The motivation for linearisation	131
9.2	What is linearisation?	131
9.2.1	An initial trivial example	131
9.2.2	Comments	132
9.3	Linearisation about a nominal trajectory: illustration	133
9.4	The derivative as best linear approximation	134
9A	<i>The inverse function theorem</i>	135
9B	<i>The concept of transversality</i>	136
10	Multivariable linear processes	137
10.1	Transfer function representations	137
10.2	State space representations	138
10.3	Design of feedback control systems	139
10.4	Time solution of the state space equation	139
10A	<i>It seems remarkable that an oscillatory solution can be generated by repeated multiplication by a constant matrix (see Figure 10.2)</i>	141
10.5	Discrete and continuous time models: a unified approach	141
10B	<i>Generation of a control sequence</i>	142
10.6	The concept of controllability for multivariable systems	143
10C	<i>Conservation of dimension under linear transformations</i>	143
11	Discrete time and computer control	145
11.1	Computers as system components – devices that can change their state only at discrete times	145
11A	<i>A simple and informative laboratory experiment</i>	146
11.2	Discrete time algorithms	147
11.3	Approaches to algorithm design	148
11B	<i>A clever manipulation – how the digital to analogue convertor (zero order hold) is transferred for calculation purposes to become part of the process to be controlled</i>	149
11C	<i>Takahashi's algorithm</i>	151
11.4	Overview: concluding comments, guidelines for algorithm choice and some comments on procedure	152

11D	<i>Some difficulties in moving from differential equations to approximating difference equations</i>	153
11E	<i>Discretisation</i>	153
11F	<i>A simple matter of quadratic behaviour</i>	154
11G	<i>Continuous is not the limit of discrete as $T \rightarrow 0$</i>	156
11H	<i>Non-uniqueness of inverse Z transforms</i>	157
11I	<i>Stability is normally considered to be a property of a system so that for any bounded input a stable system should produce a bounded output</i>	157
12	State estimation: the Kalman filter and prediction	159
12.1	State estimation – what it attempts to do	159
12.2	How a state estimator works – the Kalman filter	160
12.3	The Kalman filter – more detail	160
12.4	Obtaining the optimal gain matrix	162
12.5	Prerequisites for successful application of the Kalman filter in the form shown in Figure 12.4	163
12.6	Discussion of points arising	163
12.7	Planning, forecasting and prediction	164
	12.7.1 Approaches to prediction	165
	12.7.2 Physically based models for prediction	166
12.8	Predictive control	166
13	Non-linearity	167
13.1	What is meant by non-linearity	167
13.2	Approaches to the analysis of non-linear systems	169
13.3	The describing function method for analysis of control loops containing non-linearities	170
13.4	Linear second-order systems in the state plane	172
13.5	Non-linear second-order systems in the state plane	174
13.6	Process non-linearity – large signal problems	176
13.7	Process non-linearity – small signal problems	176
14	Optimisation	179
14.1	Initial discussion	179
14.2	Optimisation – a few ideas that can form building blocks	179
	14.2.1 Discussion	185
14.3	Time-optimal control	186
14A	<i>Time-optimal control – a geometric view</i>	188
14B	<i>The following geometric argument can form a basis for the development of algorithms or for the proof of the Pontryagin maximum principle</i>	191
14C	<i>Construction of time-optimal controls</i>	192

15	Distributed systems	195
15.1	The cosy idealisation that a system can be characterised by its behaviour at a point in space	195
15.2	Alternative approaches to the modelling of distributed systems	196
15.2.1	The representation of a spatial region as the summation of elemental regions	196
15.2.2	A ‘Fourier type’ approach, in which an arbitrary function f on an interval $[0, 1]$ is approximated by a summation of functions f_i	197
15A	<i>When can the behaviour in a region be well approximated at a point?</i>	198
15B	<i>Oscillating and osculating approximation of curves</i>	199
16	An introduction to robust control design using H_∞ methods	201
16.1	Motivation	201
16.2	Hardy spaces (H_p , $p > 0$ spaces) and their relevance to control problems	201
16.3	A simple view of H_∞ control loop design	204
16.3.1	Guaranteed stability of a feedback loop	204
16.3.2	Robust stability of a closed loop	205
16.4	Total internal stability and design for disturbance rejection	206
16.4.1	Setting the scene	206
16.4.2	Robust stability	207
16.4.3	Disturbance rejection	208
16.5	Specification of the ΔG envelope	210
16.6	Deriving H_∞ norms from dynamic process models	211
16.6.1	Singular values and eigenvalues	211
16.6.2	Eigenvalues of a rectangular matrix A	212
16.6.3	Singular values and their relation to eigenvalues	213
16.6.4	Relations between frequency and time domains	213
16.7	A promising visualisable design tool that works within the H_∞ frame: the ν gap metric	214
16.7.1	Introduction	214
16.7.2	Simple illustration of the use of the ν gap metric	215
16.7.3	More about the two metrics δ_ν and $b_{G,D}$	215
16.7.4	The insight provided by the ν gap metric	217
16.7.5	Taking into account the weights shown in Figure 16.13 to allow loop shaping	218
16.7.6	A discussion on the two metrics δ_ν and $b_{G,D}$	218
16.8	Adaptivity versus robustness	219
16A	<i>A hierarchy of spaces</i>	220
16.9	References on H_p spaces and on H_∞ control	222

17	Neural networks, fuzzy logic, genetic algorithms, learning systems, intelligent systems	225
17.1	Introduction	225
17.2	Artificial neural networks (ANN)	226
17.2.1	Motivation	226
17.2.2	A basic building block – the neuron	227
17.2.3	Simple properties of a neuron demonstrated in the two dimensional real plane	227
17.2.4	Multilayer networks	229
17.2.5	Neural network training	230
17.2.6	Neural network architectures to represent dynamic processes	231
17.2.7	Using neural net based self-organising maps for data-reduction and clustering	233
17.2.8	Upcoming rivals to neural networks? – support vector machines (SVMs) and adaptive logic networks (ALNs)	234
17.2.9	Neural nets – summary	234
17.3	Fuzzy set theory and fuzzy logic	235
17.3.1	Introduction and motivation	235
17.3.2	Some characteristics of fuzzy logic	237
17.3.3	References: early pioneering work	238
17.4	Genetic algorithms	238
17.4.1	Basic ideas	238
17.4.2	Artificial genetic algorithms	239
17.4.3	Genetic algorithms as design tools	240
17.4.4	GA summary	241
17.4.5	References	242
17.4.6	Rivals to GAs? Autonomous agents and swarms	242
17.5	Learning systems (systems that learn) with or without supervision	242
17.5.1	Basic ideas	242
17.5.2	Learning versus adaptivity	243
17.5.3	Structural characteristics of an abstract learning system	243
17.6	Intelligent systems	244
17.6.1	The properties that an intelligent system ought to possess	244
17.6.2	Selected references	246
17A	<i>The idea of a probing controller</i>	246
18	Review – the development of control theory and the emergence of artificial intelligence (AI) techniques	249
18.1	A rapid review of how control theory developed	249

18.2	The emergence of AI techniques	252
18.3	Control applications are now embedded within an IT infrastructure	253
18.4	Summary	253
18.5	How intelligent are AI (artificial intelligence) methods?	253
18.6	What is intelligent control?	254
19	References and further reading	255
19.1	Library books	255
19.2	Other sources	255
19.3	Mainstream control literature	256
19.4	Older mainstream control books	256
19.5	Methodologies for economic justification of investment in automation	257
19.6	State estimation	257
19.7	Non-linear systems	257
19.8	Optimisation	257
19.9	Distributed parameter systems	258
19.10	H_p spaces and H_∞ (robust) control	258
19.11	Neural networks and support vector methods	258
19.12	Fuzzy logic and fuzzy control	259
19.13	Genetic algorithms, genetic programming and other parallel evolutionary search methods	259
19.14	Intelligent and learning systems	259
19.15	Adaptive and model-based control	259
19.16	Stochastic aspects of control	260
19.17	Some other control topics	260
19.18	General mathematics references	260
19.19	Ordinary differential equations	261
19.20	Differential topology/differential geometry/differential algebra	261
19.21	Theory of equations	262
19.22	Operator theory and functional analysis applied to linear control	262
19.23	Books of historical interest	263
19.24	Miscellany	264
19.25	Useful tables	264
19.26	Alphabetical list of references and suggestions for further reading	264
	Notation	285
	Index	289

Chapter 1

Control concepts: a non-mathematical introduction

1.1 General systems ideas

The objects under study in control theory are systems. A system is any set of elements connected together by information links within some delineated system boundaries.

Referring to Figure 1.1, note that the system boundary is not a physical boundary but rather a convenient fictional device. Note also how information links may pass through the system boundary.

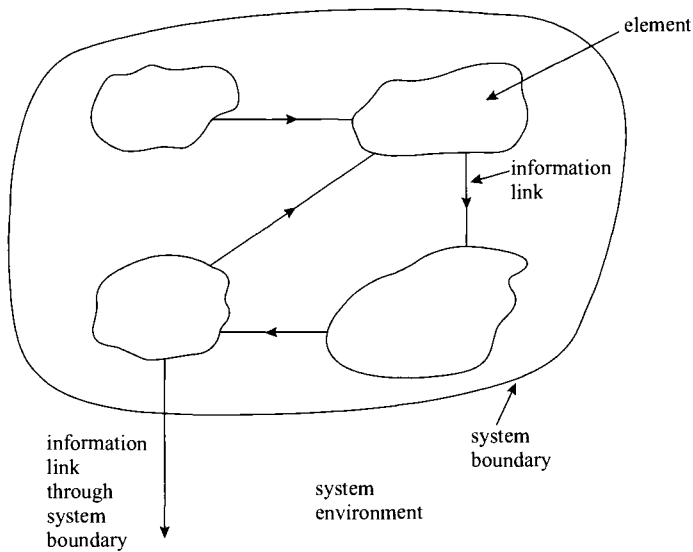

Figure 1.1 The structure of a system

Since control theory deals with structural properties, it requires system representations that have been stripped of all detail, until the main property that remains is that of connectedness. (The masterly map of the London Underground system is an everyday example of how useful a representation can be when it has been stripped of all properties except that of connectedness.)

Connectedness is a concept from topology. Topology, the discipline that studies the underlying structure of mathematics, offers fascinating reading to aspiring systems theorists. Recommended reading is given in the Bibliography. Clearly, a system is a very general concept; control theory is most interested in certain classes of system and to make progress we delineate the classes. First it is interested in dynamic systems – these are systems whose behaviour over a time period is of interest. Thus if a system were concerned with population aspects, a similar dynamic system would be concerned with population growth.

Secondly, it is most interested in and most powerful when dealing with linear systems. A linear system is characterised by the property shown in Figure 1.2. The upper part of the figure shows a system's response to some arbitrary stimulus. The lower part shows how, in the presence of linearity, the response to a scaled-up version of the stimulus is simply a scaled-up version of the previous response, with proportionality being preserved.

Finally, it is interested in feedback systems – these are systems where information flows in one or more loops, so that part of the information entering an element may be information that previously left that element (Figure 1.3).

Systems are often visualised in the form of block diagrams, illustrating the main functions, their supposed interconnection and (possibly) their interconnection to the environment of the system. Thus, a simple representation of the human temperature regulation system might be as shown in Figure 1.4.

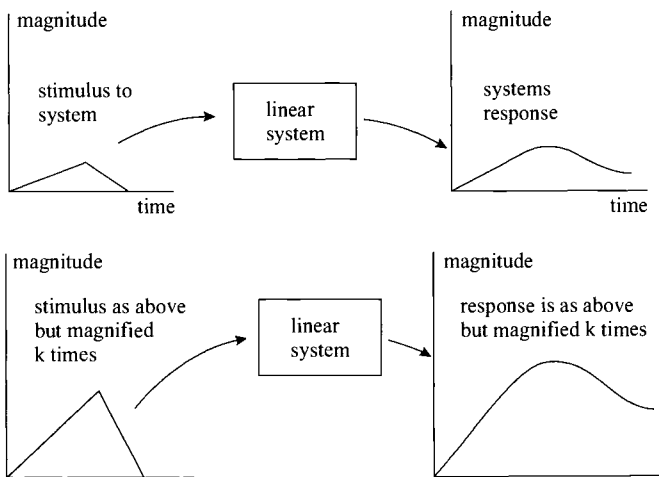

Figure 1.2 *Linear system characteristics*

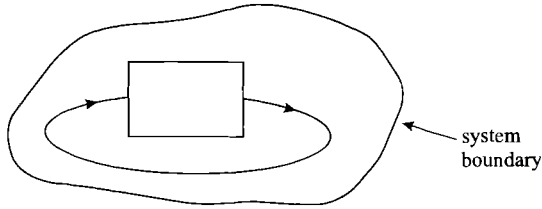

Figure 1.3 A simple feedback system

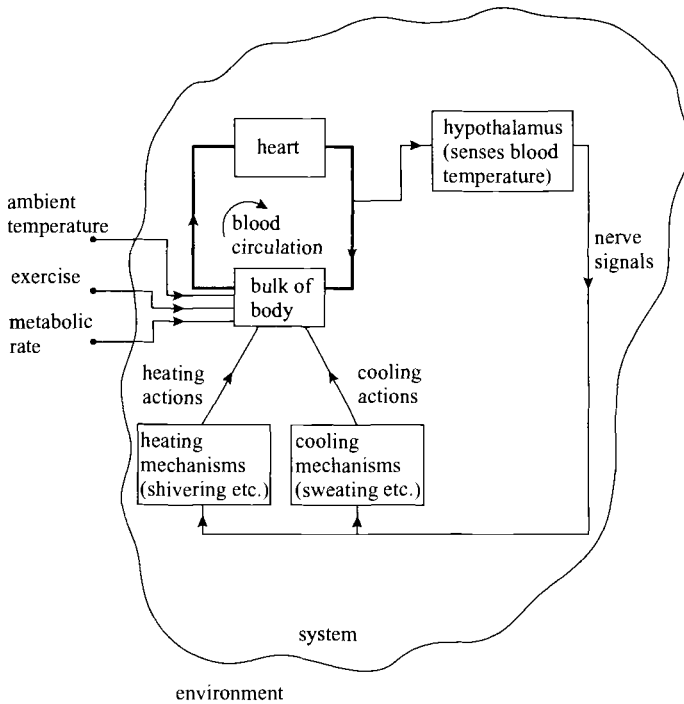

Figure 1.4 A simple representation of the human temperature regulation system

1.2 What is control theory? – an initial discussion

Many areas of study are fortunate in that their titles trigger an immediate image of their scope and content. For instance, the names ‘human anatomy’, ‘veterinary medicine’, ‘aeronautical engineering’ and ‘ancient history’ all conjure up coherent visions of well-defined subjects. This is not so for control theory although almost everyone is interested in control in the sense of being able to achieve defined objectives within some time frame. Rather specific examples occur in the named professions of ‘financial controller’ and ‘production controller’.

Control theory applies to everyday situations, as in the examples given above, just as well as it applies to the more exotic task of manoeuvring space vehicles. In fact, the concepts of control theory are simple and application-independent. The universality of control theory means that it is best considered as applied to an abstract situation that contains only the topological core possessed by all situations that need to be controlled. Such an abstract situation is called a system.

The argument is that if we know how to control a highly general situation called a system then we shall be able to control any and every particular situation. This is the viewpoint of control theory and it is this viewpoint that gives it its extraordinary power.

Thus any situation, delineated from its environment for study, is called a system. When control theory wishes to study temperature regulation in the human body, it concerns itself with a system involving blood circulation, heat generation and heat loss mechanisms and decision-making by the brain. Systems can usefully be defined in almost any discipline – they are not confined to science or engineering.

Control theory concerns itself with means by which to alter the future behaviour of systems. For control theory to be successfully applied, there needs to be available:

- (i) A purpose or objective that is linked with the future state of the system. (Clearly the past cannot be influenced nor, since no response can take place in any system in zero time, can the present.)

The objective of any control system in every case is connected with the performance of the system over some period of time – the accountant and the industrial manager want to see long periods of smooth and profitable operation. Sometimes this leads to conflicting requirements, in the sense that short term objectives are frequently in direct opposition to long term objectives. In general terms this objective can be considered to be the desired behaviour of the system.

- (ii) A set of possible actions that offers an element of choice. (If no variation of actions is possible, control cannot be exercised and the system will follow a course that cannot be modified.)
- (iii) (Unless a trial and error strategy is to be adopted) some means of choosing the correct actions (ii) that will result in the desired behaviour (i) being produced.

In general terms, this requirement is met by a model capable of predicting the effect of control actions on the system state. Such a model may be implicit and not even recognised as a model or it may consist of a large and complex set of equations.

For the accountant, the model is a balance sheet together with inherited wisdom. For the military commander, the model is a map of local terrain and a knowledge of the types and deployments of men and equipment. For the control of quantities that can be measured by sensors, mathematical models in the form of stored curves or sets of equations will usually be used.

We see then that to achieve successful control we must have a defined objective and be able to predict adequately, over some sufficient time scale, all the outcomes of all the actions that are open to us. For instance, a national power station building programme can only be planned once predictions of the future demand for electricity are available. Figure 1.5 summarises the three requirements needed for successful control.

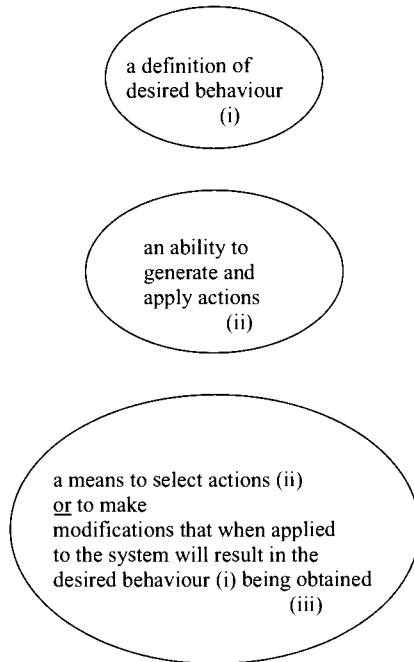

Figure 1.5 The three elements needed for successful control design

A major problem in control using a long term horizon is uncertainty of the long term accuracy of models, compounded by the likelihood of unforeseen events. That is to say, the possibility must be faced that, once uncertainty rises above a particular level, no meaningful control can be implemented and that policies that look ahead to anticipate future contingencies may call for immediate sacrifices that will never be repaid by the creation of more favourable future environments.

Feedback control, in which an error initiates corrective action, can be used only where corrective actions take effect relatively quickly. It is clearly unsatisfactory to wait until electricity demand exceeds the maximum possible supply level before starting to build a new power station. On the other hand, it is usually perfectly feasible to control the speed of a motor by an error-driven feedback correction.

None of the processes that we are called upon to control can be made to change its state instantaneously. This is because all processes have the equivalent of inertia. Suppose that we have the task of moving a large spherical boulder from A to B by brute force (Figure 1.6).

Clearly, considerable initial effort must be expended to get the boulder rolling and a similar effort must be expended to bring it to rest. In the case illustrated, it will be all too easy to overshoot the target or to spend too long arriving there if any miscalculation is made. The difficulty of achieving control in this situation is entirely typical and occurs because of the energy that needs to be stored in and then removed from the boulder to allow the task to be achieved. Only when we possess a prior

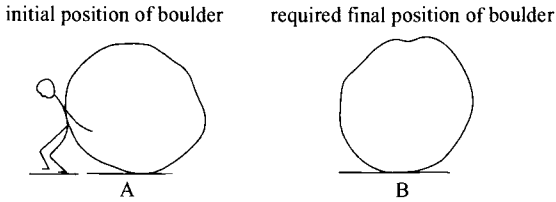

Figure 1.6 The problem of moving the boulder

quantitative knowledge of the energy storage mechanism can we hope to achieve fast and accurate control.

A system with internal energy storage is called a dynamic system. Thus, we can see that one of our chief problems is to synthesise actions that, when applied to a dynamic system, will produce the response that we are seeking.

1.3 What is automatic control?

Control theory was developed to support the emergent activity of automatic control. It is therefore a useful motivation to turn our attention to automatic control. Historically, the discipline of automatic control was concerned with the replacement of the human worker of Figure 1.7 by the automatic controller of Figure 1.8.

Although automatic control is nowadays a complex discipline, no longer primarily concerned with the replacement of human operators, it is a useful starting point to consider what sort of skills are necessary to move from an existing, manually controlled situation to a new automatically controlled situation, as in Figure 1.8.

- (1) A central idea of control theory is the control loop. All control loops have the same basic form, regardless of the particular application area. Thus, control theory uses an application-independent notation to convert all control problems into the same standard problem. We can consider that control theory concentrates on studying the universal situations that underlie all applications of quantitative control.

In broadest form a control loop appears as in Figure 1.9. The decisions govern actions that are taken. The effect of the actions is reported back by the information channel. Further decisions are taken and the loop operates continuously as described. A control loop provides an extraordinarily powerful means of control but, at the same time, the existence of the loop always brings the possibility of the potentially very destructive phenomenon of instability.

- (2) All control loops are error-driven, where error is defined as the difference between the behaviour that is desired and the behaviour that is measured.
- (3) An important performance measure for a control system relates to rate of error reduction. Often, performance is quoted in terms of the highest frequency that the control system can follow, when required to do so.

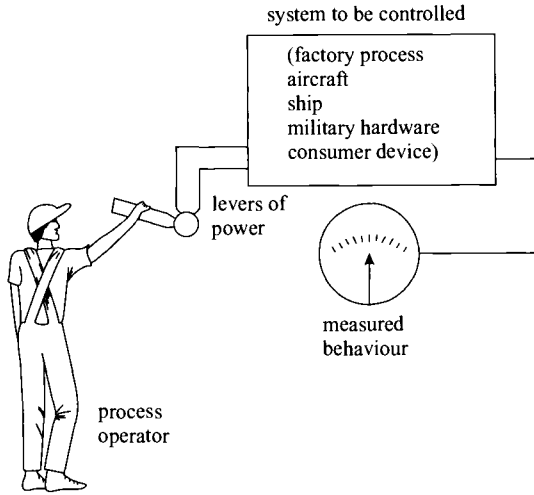

Figure 1.7 A manually controlled process

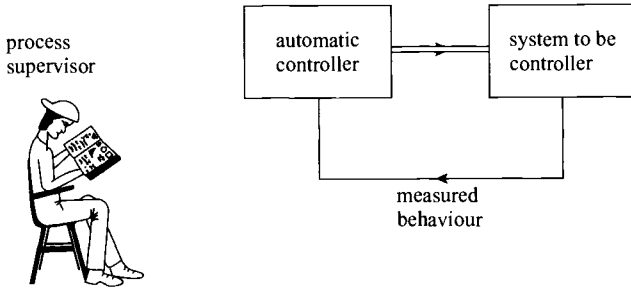

Figure 1.8 The process of Figure 1.7 now under automatic control

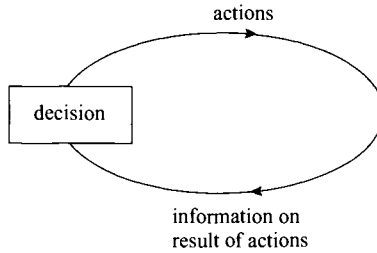

Figure 1.9 A control loop in its broadest form

- (4) All control loops tend to become unstable as higher and higher performance is sought. A good understanding of the topic of stability is central to understanding control theory.

1.4 Some examples of control systems

Four control systems are illustrated in Figure 1.10. All can be seen to have the form of Figure 1.11. A user, uninterested in the mechanics of all this, will see the simpler view of Figure 1.12. We refer to this single block (that has the control loop hidden inside) as the control system.

The following further points are important:

- (5) Control system performance can only be meaningfully specified in relation to the (total) control system of Figure 1.12.

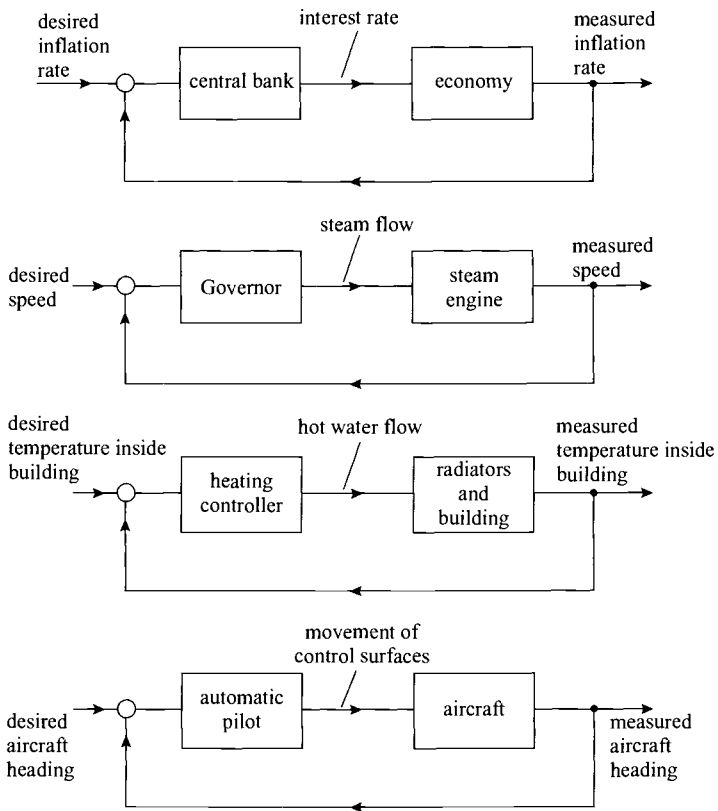

Figure 1.10 *Some examples of particular control applications*

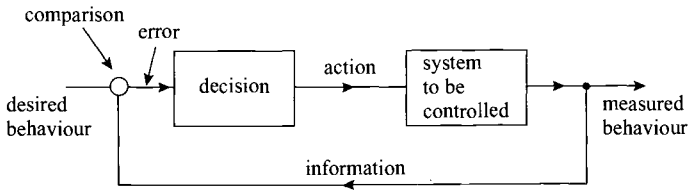

Figure 1.11 The general form of all the control systems in Figure 1.10

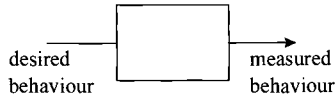

Figure 1.12 A user's view of the control system of Figure 1.11

- (6) The control system designer almost always has to incorporate into the control loop an element whose intrinsic behaviour is largely outside his own influence. (For instance, the control systems designer may have little influence on the design of a building although later he will be called upon to design temperature control systems for it.)
- (7) To quite a large extent, the controller must neutralise adverse characteristics in the process, compensating for non-ideal process configurations and for short and long term perturbations and variabilities.
- (8) For (7) to be possible, the process characteristics must be known to some degree of accuracy and be reasonably constant.
- (9) Ideally [see (6)] the control system designer will ensure that the process has the best possible inherent behaviour, even with no control. The control design cycle is therefore roughly:
 - (a) Decide on a necessary performance specification.
 - (b) Quantify the performance of any system-to-be-controlled element that is to be included in the control loop.
 - (c) Design, by one or other control design techniques, a controller so that the control system meets the specification of (a).
 - (d) Construct, commission and test the control system.

In the next chapter, we take these ideas further.

Chapter 2

**Control design ideas:
a non-mathematical treatment**

2.1 Initial discussion

In the previous chapter we saw that prerequisites for control design were broadly: a defined objective, a set of available actions and a model that could be interrogated to establish which of the available actions would best move the system towards meeting the objective. Now we add more structure to the concepts to put forward a possible design methodology (Figure 2.1). In this methodology, central use is made of a system model. This model is assumed able to rapidly calculate the expected behaviour of the system when subjected to any particular action.

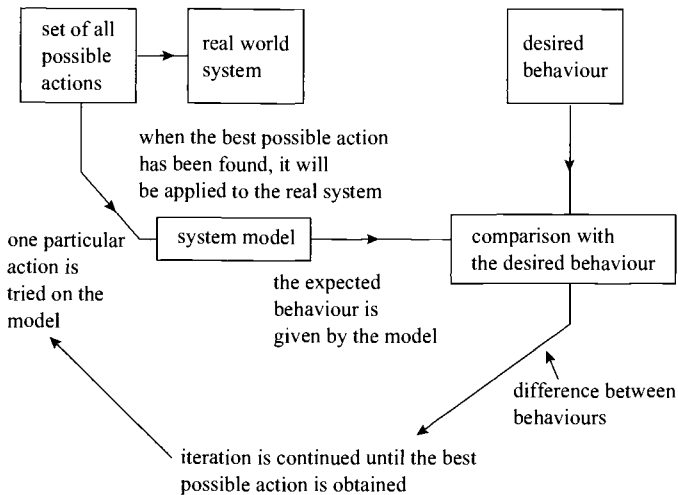

Figure 2.1 A possible methodology for control system design

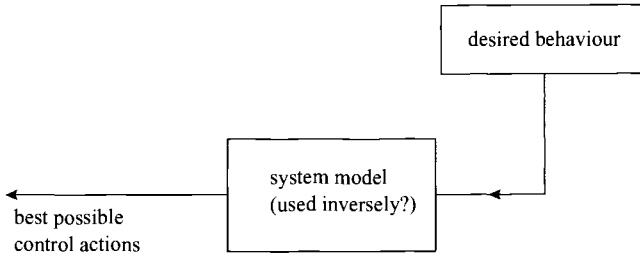

Figure 2.2 *The idea of using a system model inversely to synthesise actions*

Questions that immediately arise are:

- In practice can a realistic model be produced? If so how?
- By what mechanism can two sorts of behaviour be compared?
- Can the difference between desired behaviour and expected behaviour be meaningfully used to help the iteration towards the best possible choice of action?
- How fast would the iterative procedure, involving the model, have to operate in order for the real world system to be realistically controlled?

We answer none of these questions directly, preferring to state that Figure 2.1 remains largely symbolic. Meanwhile we ask a further question.

2.2 Question: Can the best possible control actions be synthesised by some mechanism?

If the system model and the desired behaviour are accurately defined should it not be possible, in one pass, to synthesise the necessary actions shown in Figure 2.1 without interactive searching?

This question is illustrated graphically in Figure 2.2.

2.3 Requirements for an automatic control system

If it is possible to synthesise the best possible actions continuously by some sort of algorithm, then we have arrived at automatic control.

In the best known and simplest form of automatic control, the desired behaviour is specified as a requirement that the measured system response (say y) should continuously and closely track a required system response (say v) that is input by the system user (Figure 2.3).

Of course, v may be constant or even always set equal to zero. In such cases, an automatic control system has the task of keeping a measured value of y always equal to the specified constant value of v , despite the presence of disturbing influences. These general requirements of an automatic control system are shown in Figure 2.4. Moving more towards the realisation of a practical system, Figure 2.5 results.

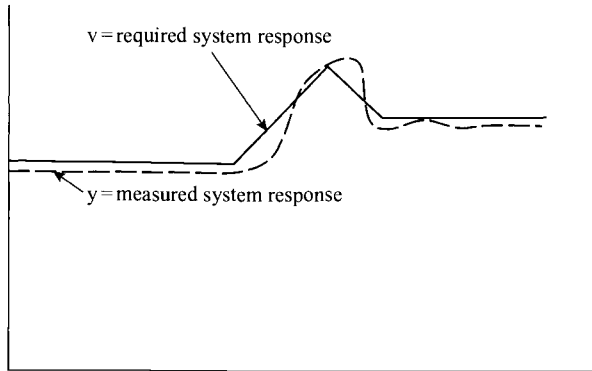

Figure 2.3 An automatic control system may be required to force the measured response y to track a user-specified desired response as closely as possible

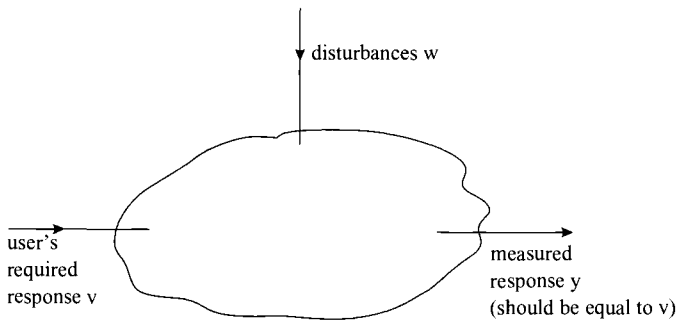

Figure 2.4 Requirements for an automatic control system

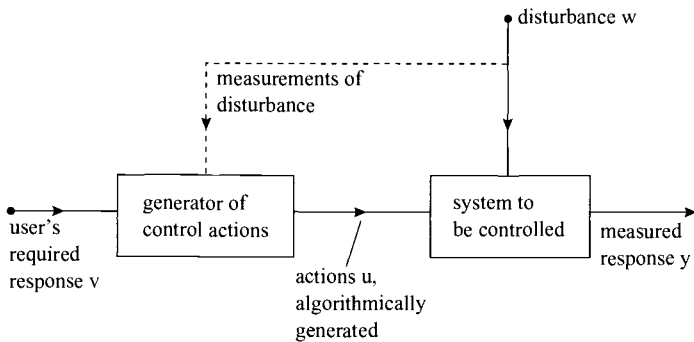

Figure 2.5 Realisation of an automatic control system

It is clear that the success of the scheme presented in Figure 2.5 depends on the disturbances w being measurable and on the existence of an accurate quantitative understanding of the system to be controlled, for otherwise the ‘generator of control actions’ cannot be accurately constructed. (Notice that no use is made of any measurement of the response.)

2.4 Automatic feedback control

Automatic feedback control overcomes both the above problems (possible unmeasurability of disturbances, difficulty of obtaining a sufficiently accurate model) by being error-driven as shown in Figure 2.6.

2.5 Diagrams illustrating and amplifying some of the concepts described so far and showing relationships to a software engineering context

- (1) Control theory is interested in systems behaviour and deals with generalised situations called systems. A system is a set of elements, interconnected by information links and existing within a system boundary outside which is the system environment. Figure 2.7 illustrates some of the rationale.
- (2) A broad task is to go from a statement of ‘desired behaviour’ to the synthesis of a system exhibiting that desired behaviour (Figure 2.8).
- (3) In more specific terms, control theory is first concerned with systems understanding, secondly with influencing systems behaviour, and thirdly with designing systems to exhibit particular behaviours (Figure 2.9).

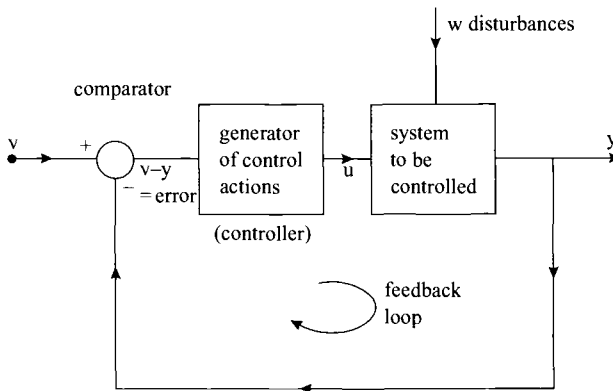

Figure 2.6 An ‘error driven system’: the feedback loop

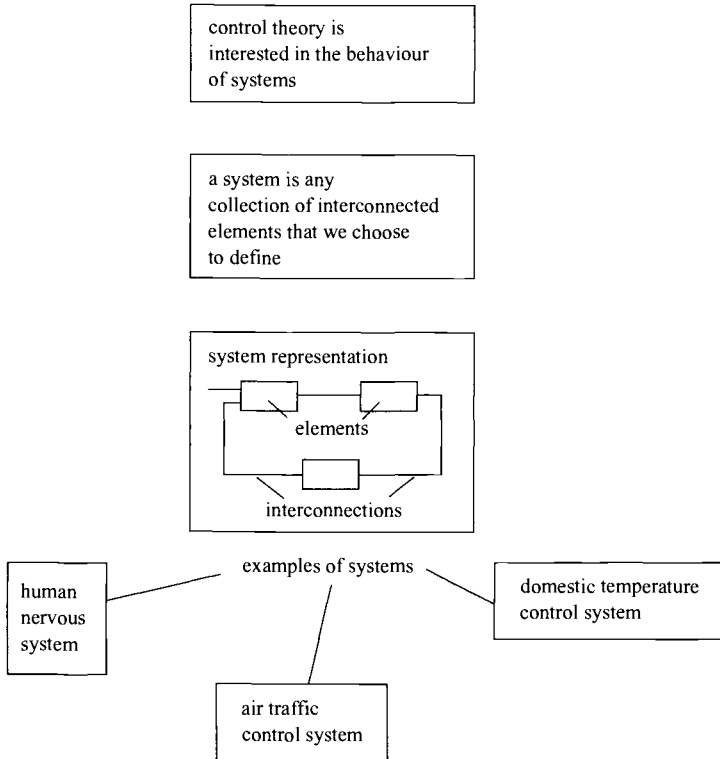

Figure 2.7 Some basic control ideas

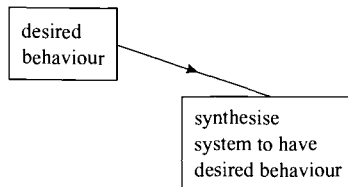

Figure 2.8 The broad task of control design

Virtually every important application of control theory is closely embedded within a complex software engineering context. Without attempting to go into details the following concept diagrams illustrate some of the interactions between control design approaches and the software context:

- (4) Once systems behaviour is considered, the questions arise: what types of behaviour do we have in mind? How can behaviour be quantified? What factors limit performance? (Figure 2.10).

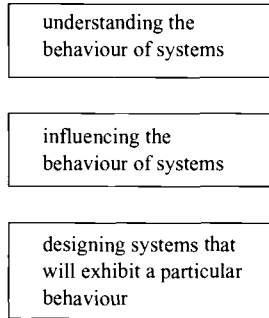

Figure 2.9 The sequence of objectives involved in a typical control project

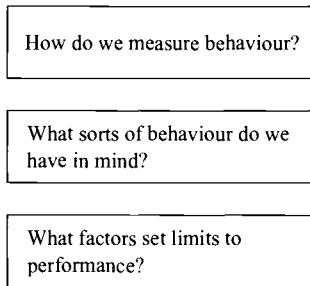

Figure 2.10 Fundamental questions related to system behaviour and system performance

- (5) Elaborating on the points in Figure 2.10, we turn to points of methodology. How can we find out what type of system is really required? How can we turn this knowledge into a specification and then into a design? What tools are available to assist us? Figure 2.11 illustrates these points.
- (6) Elaboration of the points in Figure 2.11 produces Figure 2.12. Here we see a stage called 'requirement capture' dedicated to establishing what the eventual user needs. Further stages of systems specification, system design, knowledge elicitation (aimed at feeding in particular expert knowledge) and data base design precede the writing of code (i.e. programming) and the proving, commissioning and maintenance that are essential parts of all real applications.
- (7) Figure 2.13 is a re-run of Figure 2.12 with a few enhancements. This figure illustrates how a user's conception of the ideal system is modified by additional enhancements as well as by restrictions suggested by a systems designer's expertise. The role of CASE (Computer Aided Software Engineering) tools can be seen in the diagram. These tools allow systematic top-down design,

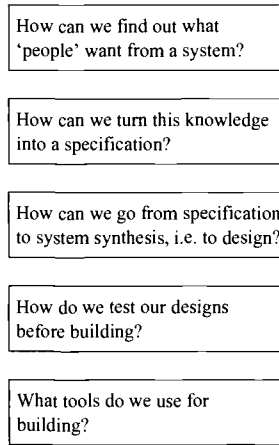

Figure 2.11 *The beginnings of a methodology for system design*

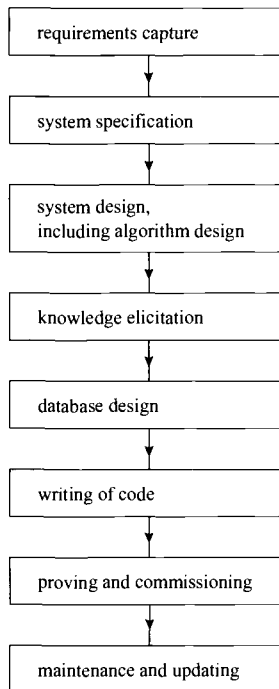

Figure 2.12 *System design from requirements capture to commissioning and maintenance*

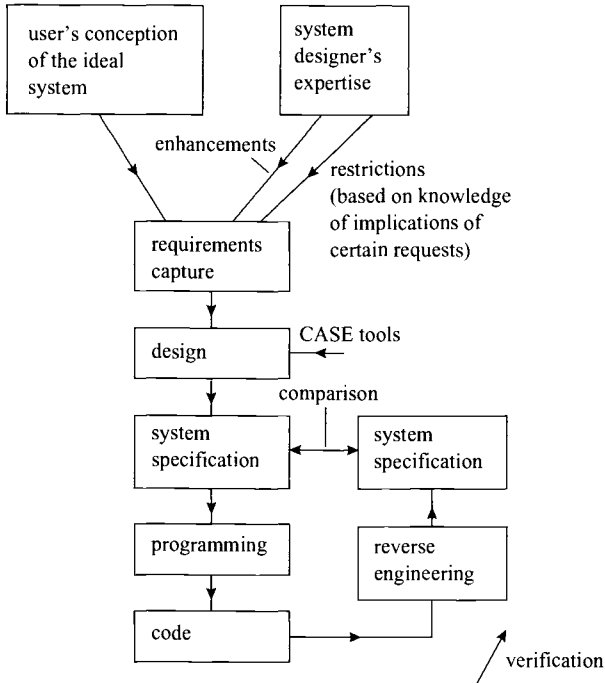

Figure 2.13 A more detailed view of system design showing the role of CASE tools and the place of verification using reverse engineering

partitioning of work tasks into manageable parcels, continuous checks on consistency and a graphical overview of the whole design project. The figure also illustrates how so called reverse engineering is used to check that the final codes are in complete and consistent agreement with the initial system specification.

Chapter 3

Synthesis of automatic feedback control loops: a more quantitative view

3.1 Feedback loops: further discussion

In automatic control a device called a controller issues commands that are physically connected to a process with the intention to influence the behaviour of the process in a particular way. The commands that will be issued by the controller in a particular set of circumstances are completely determined by the designer of the controller. Thus, automatic control can be seen to be completely pre-determined at the design stage.

The controller may be driven by time alone or it may be driven in a more complex way by a combination of signals. In feedback control, the controller is error driven. That is, the controller receives a continuous measurement of the difference between required behaviour and actual behaviour and its output is some function of this error (Figure 3.1).

In this type of system, excellent results can be obtained in practice with very simple controllers indeed, even when operating under conditions where the system to be controlled is not well understood. Roughly speaking, we can imagine that the controller will keep on taking corrective action until the error is reduced to zero.

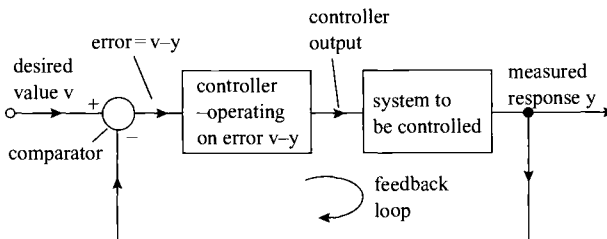

Figure 3.1 A feedback control loop

Notice that the output of the controller is a function of error $v - y$.

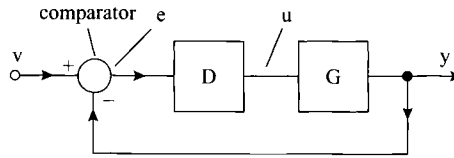

Figure 3.2 A feedback loop with the system to be controlled denoted G and the controller denoted D

An alternative view of the arrangement of Figure 3.1 is that the user sees an artificially enhanced system that has been synthesised to meet his wishes. If we represent the controller by an operator D and the system to be controlled by an operator G we obtain:

$$\left. \begin{array}{l} \text{System output} = Gu \\ \text{Controller output} = De \\ \text{Controller input} = e = v - y \end{array} \right\} \quad (3.1)$$

In feedback controller design, the task is to specify the controller, denoted by the operator D , so that in connection with the process, denoted by the operator G , in the format shown, a suitable overall behaviour will be obtained. We can imagine that the controller modifies the process characteristics in ways chosen by the designer.

We next assume that there exists a desired hypothetical process H . By suitable connection of a controller D to the actual process, are we able to produce a configuration that behaves the same as H ?

If we interconnect G and D as shown in Figure 3.2 and assume some benevolent mathematics that allows us to manipulate the symbols then, from the figure,

$$\begin{aligned} y &= GD(v - y) \\ \frac{y}{v} &= \frac{GD}{1 + GD} \end{aligned} \quad (3.2)$$

and setting

$$D = \frac{H}{G(1 - H)} \quad (3.3)$$

will be found to accomplish the objective of making y/v equal to H . In other words, this choice of D does indeed make the synthesised configuration behave like the chosen hypothetical process H .

Here we assume that well-behaved operators can be found to operate on the sort of functions that exist in the control loop and possessing those other properties of associativity and invertibility that are needed to make manipulation valid. (i.e. we assume that the operators G , D , H are elements in a group).

Laplace transforms or other techniques can produce these operators for specific examples but, for the moment, it is sufficient to know that such operators exist. Then,

from the set of equations above, it is clear that

$$y = [(1 + GD)^{-1}GD]v \quad (3.4)$$

and the system represented by the operators in the square brackets can be synthesised by choice of D to behave as the user requires.

We note and ask:

D contains G^{-1} , the inverse of the plant:

- This may be of high order.
 - Is it (G) known?
 - Does it (G) stay constant?
 - If G changes by (say) 10% will control become very poor?
- (i) Can our requirements be adequately represented by an operator H ?
 - (ii) How is H chosen?
 - (iii) Is it not disturbing that H is not in any way dependent on G ? For instance, can we turn a low-performance aircraft (G) into a high-performance aircraft (H) simply with the aid of a clever algorithm?
 - (iv) Does D turn out to be a possible, buildable, robust, practical controller?

Comment

Limits on attainable performance are set by the constraints in the process. These constraints are not at all modelled by the (linear) operator G , nor are they otherwise fed into the design procedure.

A key point is: if H is chosen too ambitiously then D will simply drive the process G into saturation.

In practice, a particular process G can nearly always be marginally improved to (say) a faster responding H whereas it will rarely be able to be improved by several orders of magnitude.

The chief difficulty therefore lies in specifying H – How ambitious can we be?

3.2 What sorts of control laws are there?

It would appear reasonable that an infinite variety of control laws might be possible including some highly exotic versions that would need considerable computer power for their implementation. However, we shall show that if the control law is restricted to be linear, then the range of possible control laws is very restricted indeed.

Without much loss of generality, we may assume that the control law is to be implemented by an idealised computer that occupies the ‘controller’ position in Figure 3.1.

The output of the controller at any instant of time can be any function of the current and/or previous error signal that is read into the controller. (Recall that the system is operating in real time and that, therefore, future values of error cannot, by definition, be available to the controller.)

If linearity is now insisted on in the controller, then the possible control laws are severely restricted to be of the form:

$$\begin{aligned} \text{Present output of the controller} = & \text{Some multiple of the present input} \\ & + \text{Multiples of the previous inputs} \\ & + \text{Multiples of the previous outputs} \end{aligned}$$

In other words, the present output of the controller is constrained to be just a weighted sum of present and past values of the input to and the output from the controller.

Corollaries

- (i) More ‘intelligent’ control laws may contain models of the process to be controlled and, using these models, for instance in rapid iterative simulation mode, they may calculate and produce a control output. Such control laws are not linear and theoretical calculation of their expected performance is therefore a difficult task.
- (ii) The restricted class of control laws that can be implemented linearly excludes many optimal control strategies. This is why so often optimal control solutions appear as pre-specified (open loop) functions of time that cannot be converted into automatic feedback controllers except in a minority of cases.
- (iii) Specifically non-linear controllers have found very little application. This is surprising since most processes that have to be controlled are fairly non-linear and it would seem that non-linearity in the process could surely be cancelled by ‘opposing’ non-linearities in the controller to give overall good control. Also, Nature is a well-known user of non-linear devices in most of its control applications, in, for instance, the human body, and we might reasonably expect control design to follow in this direction.

3.3 How feedback control works – a practical view

The illustrations use temperature control and foreign currency exchange control but the results are valid for any feedback loop.

Block G (Figure 3.3) is a heating process. It receives an input of ‘fuel flow’ and produces an output ‘temperature’.

Block D (Figure 3.4) is a motorised fuel valve. When the control signal is zero, the valve produces a fuel flow u_0 . When the control signal is positive the fuel flow is increased as shown in Figure 3.5. The larger the control signal, the steeper the rate

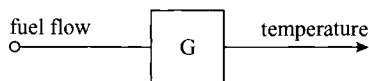

Figure 3.3 A heating process viewed as an input–output device

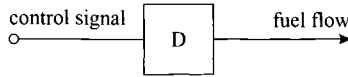

Figure 3.4 A controller for connection to the heating process

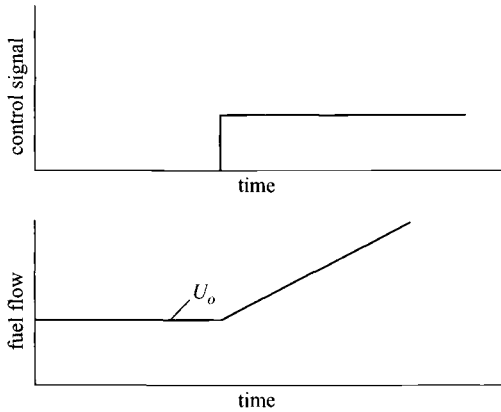

Figure 3.5 The characteristic of the controller D : how the control signal causes changes in fuel flow

of increase (Figure 3.6). Conversely, negative control signals produce decreasing fuel flows.

If now the feedback loop in Figure 3.7 is formed, the input to the motorised valve D is the difference between the temperature that is desired and the actual (measured) temperature.

Assume that the measured temperature is 80°C and the desired temperature is 100°C .

Then the input received by the valve D will be $100 - 80 = 20$. This is a positive signal and valve D will respond by increasing the fuel flow. Heating process G , on receiving an increased fuel flow, will respond by increasing its temperature so that it will climb above 80°C . The error will decrease and the fuel flow will settle eventually at that value that brings the measured and desired temperatures to be equal, i.e. to a zero error condition. The operation just described is illustrated in Figure 3.8.

Notice carefully that the temperature will arrive exactly at the desired value regardless of the particular characteristics of heating process and valve. For instance, even should the heating process suddenly and unexpectedly fall in efficiency (thereby requiring more fuel to achieve the same temperature) the feedback loop will compensate perfectly for this change since the fuel flow will be increased automatically to whatever level is required to give exactly the desired temperature. Here we see the great attraction of feedback control – an imperfectly understood process, even one subject to large unpredictable changes of basic characteristics, can be satisfactorily controlled using a control law that is specified in the vaguest of terms.

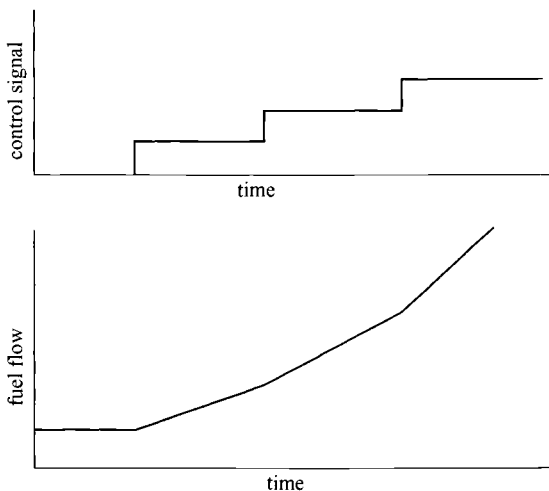

Figure 3.6 Further illustration of the characteristics of the controller D

How stepwise increases in control signal are translated into increasing rates of fuel flow

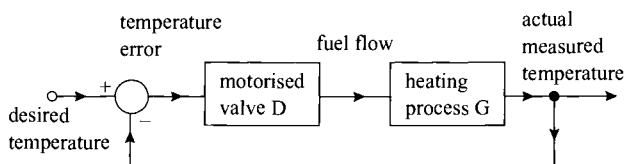

Figure 3.7 A feedback loop in which the motorised valve is connected to the heating process

Before we move on to consider the implications, let us illustrate the feedback control principle at work in a different, much wider context (Figure 3.9). Here let the element G be an economic element whose input is UK bank rate (%) and whose output is the exchange rate, number of US dollars per pound Sterling.

Assume that the Chancellor has in mind a desired exchange rate, say \$1.5 against the pound. It is 'generally accepted' that increasing the UK interest rate will increase the exchange rate. The Chancellor, D , in the feedback control loop, therefore manipulates the interest rate to whatever level is necessary to achieve the desired exchange rate (Figure 3.10).

Of course, the Chancellor does not ramp the exchange rate (as in the earlier fuel rate example) – rather he moves it in a succession of steps to form a staircase function that is all too familiar (Figure 3.11). Notice again that (fortunately) the Chancellor does not need to understand how the economy works to attain the exchange rate that he requires, using the principle of feedback.

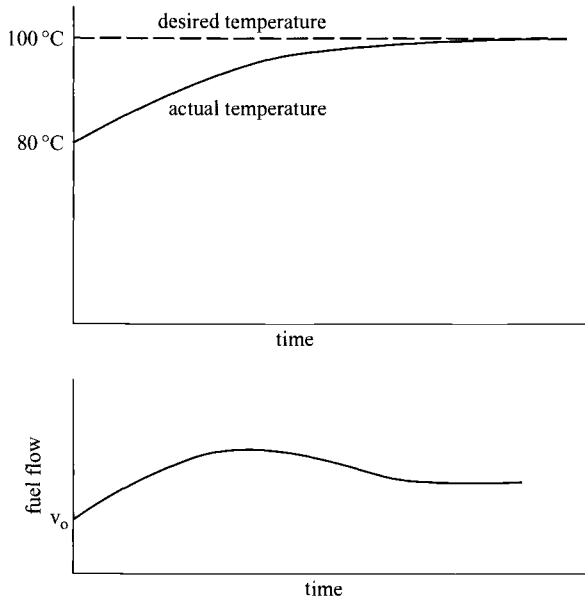

Figure 3.8 Expected behaviour of the heating process when under closed loop control

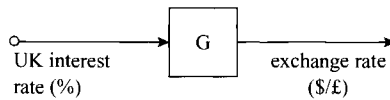

Figure 3.9 The economic element that relates exchange rate to UK interest rate

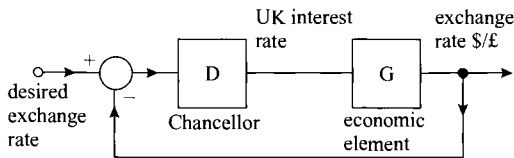

Figure 3.10 The economic element under closed loop control by the Chancellor

The feedback principle works extremely well provided that the available actions do not encounter constraints that limit their magnitudes. In the case of temperature control, there will always be some limit on fuel flow rate. In the case of exchange rate control, there will always be restraints, often of a political nature, on the magnitude of the interest rate that can be used. Linear systems have no such constraints and hence linear control theory can never deal satisfactorily with the inevitable boundedness of all real control actions.

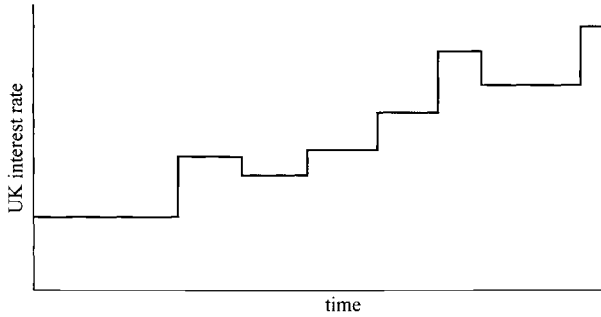

Figure 3.11 *A typical interest rate profile resulting from the Chancellor's actions*

We now return to the main theme of practical feedback control. We recall that the approach has the considerable merit that it offers exact control of vaguely specified and possibly changing mechanisms, using quite loosely specified control actions. The underlying rough idea is that the action in the control loop keeps on increasing/decreasing to whatever level is needed to make the error zero. So long as the error is non-zero, further action is taken in the direction that will reduce the error. When the error reaches zero, the value of the controlled variable is, by definition, equal to the specified desired value.

We have seen that an acceptable level of control can be obtained for imperfectly understood processes using vaguely specified actions. However it is now time to ask:

- (i) How long does it take for control to be achieved and what is the nature of the response curve?
 - (ii) Can a 'best possible response' be defined and, if so, how can it be achieved?
 - (iii) In a particular case, what sets the limit on performance?
 - (iv) What if the desired target is not constant (a moving target) or there are external influences outside our control?
- (i) Responses may range across the type of behaviour shown in Figure 3.12. It is clear that, for many applications, the nature of the response and the time taken to achieve control will be critical, yet these aspects cannot be predicted in the absence of quantitative data.
 - (ii) A 'best possible response' is only meaningful in general for problems where constraints are present. By definition, these problems do not belong to linear control theory.

Linear control systems can, by definition, use signals of any magnitude to produce responses that, in the limit, are instantaneous – such responses are clearly unattainable in practice. The difficulty is overcome in practice as follows. A required response that is realistic for the application but that is not expected to violate constraints is aimed for.

If this rather empirical approach shows that constraints would be violated, the problem has to be altered. In an engineering application more powerful motors, stronger practical components or additional amplifier stages may be needed.

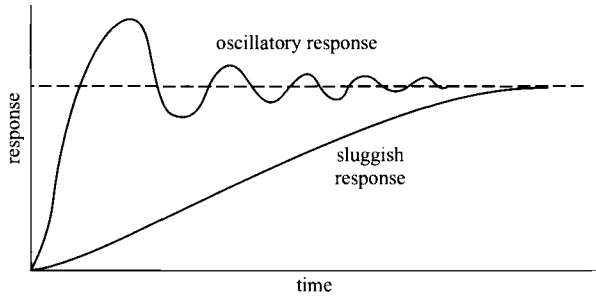

Figure 3.12 Typical transient responses ranging from highly oscillatory to sluggish

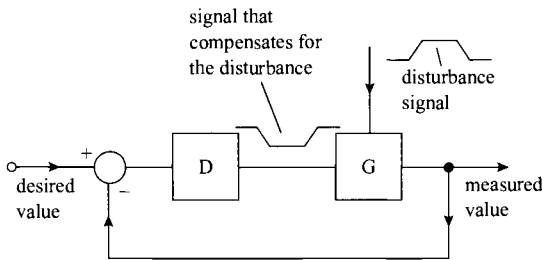

Figure 3.13 An (ideal) feedback controller will synthesise an equal and opposite signal to neutralise the effect of an incoming disturbance

The valuable point emerges: The limits of control performance are the constraints within the system; and these are not at all represented in linear control theory.

We have now reached the stage where ‘imported detail’ begins to crowd in on us, attempting to force us away from principles into a discussion of technique. At this point we are content to say that, even under conditions of moving targets, external influences and other factors yet to be discussed, viable feedback control systems can usually be designed and implemented.

3.4 General conditions for the success of feedback control strategies

By the nature of feedback control, corrective action can only begin once an error has been detected. Therefore, close control will only be possible in those cases where the rate of corrective action can at least match the rate of disturbance generation. This idea, of course, soon leads to requests for high bandwidth of control loops to allow, in one way of looking at it, the control loop to successfully synthesise a signal equal and opposite to the disturbance signal (see Figure 3.13).

In many cases, it is not possible to design a closed loop with a high enough bandwidth, and then feedback control has to be abandoned or relegated to a secondary role.

3.5 Alternatives to feedback control

Alternatives to feedback control are:

- (i) *Preprogrammed control*: Here a standard strategy, recipe or sequence of controls is calculated in advance and is implemented without regard to any signals that come from the system during the period of control.
- (ii) *Feedforward control*: Here the disturbing signals are measured and necessary corrective actions are calculated and implemented with the idea of eliminating error before it can occur. This approach requires that the disturbances are measurable independently (as opposed to the feedback approach which allows the error to be a measure of received disturbances) and that the necessary control actions are accurately calculable.
- (iii) *Prediction followed by control*: Here prediction of future conditions, either based on extrapolation algorithms, or on stored historical records, is used to allow the best possible positioning of a low bandwidth control system. A classical case is in electricity generation where rapidly changing consumer demand follows a reasonably predictable daily and seasonal pattern, thereby allowing the cumbersome process (time constant of several minutes) of bringing new generators onto the grid to be scheduled to match load predictions rather than attempting an unsuccessful feedback control in which the slow process of bringing new generators on-stream attempts to match the very much faster rate of change of consumer electricity demand.

Chapter 4

How the Laplace transform greatly simplifies system representation and manipulation

4.1 Laplace transform techniques

Many useful techniques depend on the Laplace transform. The Laplace transform of a function $f(t)$ is denoted sometimes by $\mathcal{L}\{f(t)\}$ and sometimes by $F(s)$. The inverse Laplace transform of $F(s)$ is denoted sometimes by $\mathcal{L}^{-1}\{F(s)\}$ and sometimes by $f(t)$. Figure 4.1 makes the relation clear; s is a complex variable whose role is defined by eqn. 4.1.

4.2 Definition of the Laplace transform

By definition

$$\mathcal{L}\{f(t)\} = \int_0^{\infty} \exp(-st) f(t) dt \quad (4.1)$$

Examples

- (1) Let $f(t) =$ a constant k , and let $R(s)$ denote the real part of the complex number s

$$\begin{aligned} \mathcal{L}(k) &= \int_0^{\infty} \exp(-st) k dt = -1/s \exp(-st) \Big|_0^{\infty} \\ &= 0 - (-k/s) = k/s \end{aligned}$$

provided that $R(s)$ is positive (for otherwise the integral does not exist).

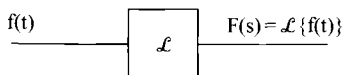

Figure 4.1 The Laplace transform operation

(2) Let $f(t) = \exp(at)$

$$\begin{aligned}\mathcal{L}\{\exp(at)\} &= \int_0^{\infty} \exp(-st) \exp(at) dt \\ &= \frac{1}{(a-s)} \exp(a-s)t \Big|_0^{\infty} = \frac{1}{s+a}\end{aligned}$$

This will be true provided that $\text{Re}(s) > a$.

The chore of calculating Laplace transforms of particular time functions and the converse problem – calculating the time function, by inverse Laplace transformation, corresponding with a particular Laplace transform – can be avoided by the use of software packages or tables of transform pairs. Small tables are to be found as appendices in many introductory control textbooks. A larger set of tables can be found in McCollum and Brown (1965) and a very comprehensive set in Prudnikov *et al.* (1992).

4A Convergence of the integral that defines the Laplace transform

It is quite typical, as in the last example, for the integral that defines the Laplace transform to be finite (and hence defined), only for restricted values of s . However, there seems to be a tacit agreement in the teaching of control theory to avoid any discussion of the distracting question: what is the significance of the region of convergence of the integral that defines the Laplace transform?

For example, let $a = 2$ in the transform $1/(s+a)$ that we have just derived. Then it is clear that the transform is only defined and valid in the shaded region in Figure 4.2 where the real part of s is strictly greater than 2. However, later in this chapter, we shall see that, for this transform, the value of s for which $s+a=0$ is highly significant

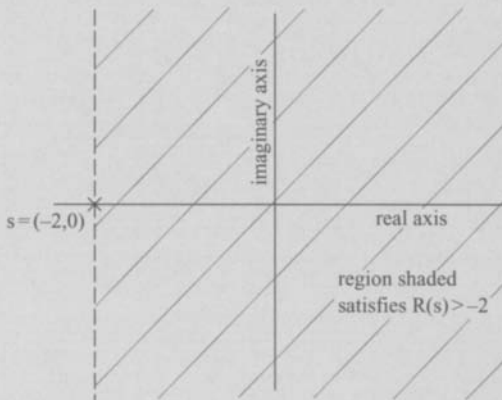

Figure 4.2 The transform $1/(s+2)$ is only defined in the shaded region, yet the point $s = (-2, 0)$ is the one of interest and the transform is universally used at that point without further question

(i.e. the point $s = (-2, 0)$). We, in common with the whole control fraternity, blithely use the transform at the point $s = (-2, 0)$ where it is undefined.
 Notice also that the region in which the integral converges may be empty. For example, the function $\exp(t^2)$ has no Laplace transform for this reason.

4B Problems with 0^- and 0^+

(i) Anyone who has used Laplace transforms to solve differential equations will be used to obtaining solutions such as

$$y(t) = y(0) \exp(-t)$$

where by $y(0)$ is meant $y(0^+)$ which has to be calculated independently. One is expected to know $y(0^+)$, but $y(0^+)$ is really part of the solution that is to be determined. Clearly $y(0^+)$ will be different from $y(0^-)$ only when there is a discontinuity at the origin. Such a situation occurs for instance in calculating the step response of a system containing a differentiator. The difficulty can sometimes but not always be overcome by exercising common sense.

(ii) A rigorous examination of the Laplace mechanism applied to a delta function unearths problems again due to the $0^-, 0^+$ phenomenon. Taking the phenomenon rigorously into account shows that $L\{\delta(t)\} = 0$, rather inconveniently, compared with $L\{\delta(t)\} = 1$, that we universally use. Zadeh and Desoer (1963) discusses the Laplace transform rigorously.

4.3 Use of the Laplace transform in control theory

(1) Consider a system (Figure 4.3) that receives an input $u(t)$ and in response produces an output $y(t)$. The response $y(t)$ is determined by the nature of the input signal $u(t)$ and by the nature of the system.

Suppose that $g(t)$ is the response of the system to a unit impulse applied at time $t = 0$. Then the response to any other input u is given by the convolution integral (see interlude 4C for further insight)

$$y(t) = \int_0^t g(t - \tau)u(\tau) d\tau \tag{4.2}$$

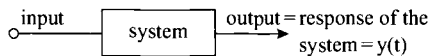

Figure 4.3 A simple input/output system

However, life is much simpler if we use the Laplace transforms of $u(t)$ and $g(t)$ to yield $u(s)$, $G(s)$, respectively, for then, equivalent to eqn. 4.2, we have

$$y(s) = G(s)u(s) \quad (4.3)$$

i.e. transform-domain multiplication is equivalent to time-domain convolution.

There is an additional advantage in that inverse transformation from $y(s)$ back to $y(t)$ is often not required – many interesting and significant questions can be answered most efficiently by reference directly to $y(s)$. The equivalence between eqns. 4.2 and 4.3 is very significant. Refer to Section 4.4 for an alternative viewpoint. Refer to Dorf (2001) for a more detailed derivation.

4.4 The concept of transfer function

The transfer function of a dynamic system with input $u(t)$ and output $y(t)$ is defined to be the Laplace transform of $y(t)$ under the condition that $u(t)$ is a unit impulse applied at time $t = 0$; or, more generally applicable in practice:

$$G(s) = y(s)/u(s), \text{ valid for any } u, y \text{ pair whose transforms exist.}$$

(2) Consider next the interconnected systems shown in Figure 4.4. Let the two systems have impulse responses $g_1(t)$, $g_2(t)$, respectively.

$$\begin{aligned} \text{Then } y(t) &= \int_0^t g_2(t - \tau)u(\tau) d\tau \\ &= \int_0^t g_2(t - \tau) \int_0^\tau g_1(t - p)v(p) dp d\tau \end{aligned} \quad (4.4)$$

However, using Laplace transformed signals and transfer functions (i.e. Laplace transformed impulse responses), we obtain, instead of eqn. 4.4,

$$y(s) = G_2(s)G_1(s)v(s) \quad (4.5)$$

4.5 System simplification through block manipulation

Block diagrams of any size and complexity can always be reduced to a single block by successive application of three rules that are summarised in Figure 4.5. The rules

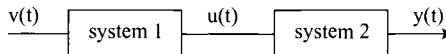

Figure 4.4 Two systems connected in series

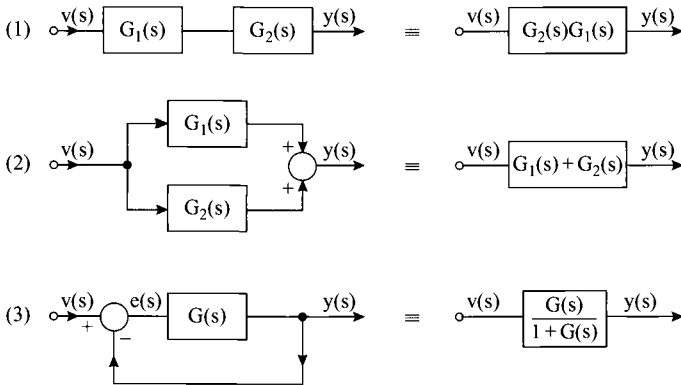

Figure 4.5 Three basic configurations and their equivalent single block representations

are easily derived as follows (rule 3 of Figure 4.5):

$$\begin{aligned}
 e(s) &= v(s) - y(s), & y(s) &= G(s)e(s) \\
 y(s) &= G(s)v(s) - G(s)y(s), & y(s)(1 + G(s)) &= G(s)v(s) \\
 y(s) &= \frac{G(s)v(s)}{1 + G(s)}
 \end{aligned}$$

Complicated block diagrams can with advantage be reduced with the aid of Mason’s rules (see Dorf, 2001).

4.6 How a transfer function can be obtained from a differential equation

If a differential equation

$$\frac{d^n y}{dt^n} + a_{n-1} \frac{d^{n-1} y}{dt^{n-1}} + \dots = b_r \frac{d^r u}{dt^r} + \dots$$

is Laplace transformed, we obtain

$$\begin{aligned}
 (s^n + a_{n-1}s^{n-1} + \dots)y(s) + \text{terms depending on initial conditions} \\
 = (b_r s^r + \dots)u(s) + \text{terms depending on initial conditions.}
 \end{aligned}$$

Transfer function analysis, but note not differential equation solution by Laplace transforms, assumes that initial condition effects have died away and that the output is a function of the input only. In that case, the transfer function corresponding with

the differential equation is

$$\frac{y(s)}{u(s)} = \frac{b_r s^r + \dots}{s^n + a_{n-1} s^{n-1}}$$

4.7 Poles and zeros of a transfer function

Any value of the complex variable s for which $G(s) = 0$ is called a zero of $G(s)$. Any value p of the complex variable s that satisfies $s \rightarrow 0 \Rightarrow G(s) \rightarrow \infty$ is called a pole of $G(s)$.

If $G(s)$ can be expressed $G(s) = P(s)/Q(s)$ then the zeros are the roots of the equation $P(s) = 0$ while the poles are the roots of the equation $Q(s) = 0$. In a pole-zero diagram, zeros are denoted by the symbol 0 and poles by the symbol \times in the complex plane.

The mathematical underpinning of the theory of transfer functions is provided by complex variable theory. Particularly relevant aspects of complex variable theory are Cauchy's integral theorem and Cauchy's integral formula, Laurent series and the associated concept of residues [These aspects can be pursued in Brown and Churchill (1996)].

4.8 Understanding system behaviour from a knowledge of pole and zero locations in the complex plane

The system to be investigated (Figure 4.6) has a single input u and a single output y . Suppose the transfer function of the system is $G(s) = P(s)/Q(s)$ where P , Q are polynomials with real coefficients in s . Since

$$y(s) = G(s)u(s) = \frac{P(s)}{Q(s)}u(s)$$

we can write

$$Q(s)y(s) = P(s)u(s)$$

Evidently $Q(s)$ governs the nature of the system's response to initial conditions and hence also its stability (since a response to initial conditions that dies away to zero belongs to a stable system and a response to initial conditions that grows with time belongs to an unstable system).

Conversely, $P(s)$ affects the manner in which the system responds to external inputs.

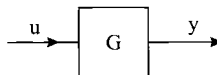

Figure 4.6 *A simple input/output system*

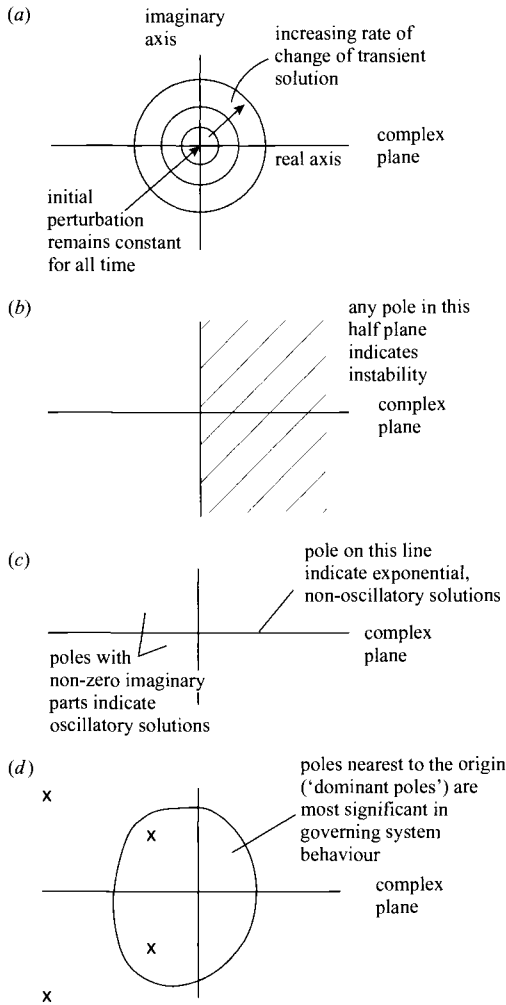

Figure 4.7 The meaning of pole locations

Meaning of pole locations

Figure 4.7 summarises some of the most important points related to the question: what is the relation between transfer function pole locations in the complex plane and the time-domain behaviour of the system?

Figure 4.7a shows how the rate of change of transient solution increases as the pole to origin distance increases; Figure 4.7b shows how any pole in the right half plane indicates instability; Figure 4.7c shows the split of the complex plane into the real line (poles on the real line indicate exponential responses) and the remainder (when poles indicate oscillatory responses); and Figure 4.7d shows how poles nearest the origin 'dominate' the response.

Zeros also have an effect on system response. Figure 4.8 gives examples of pole-zero diagrams and their associated system step responses.

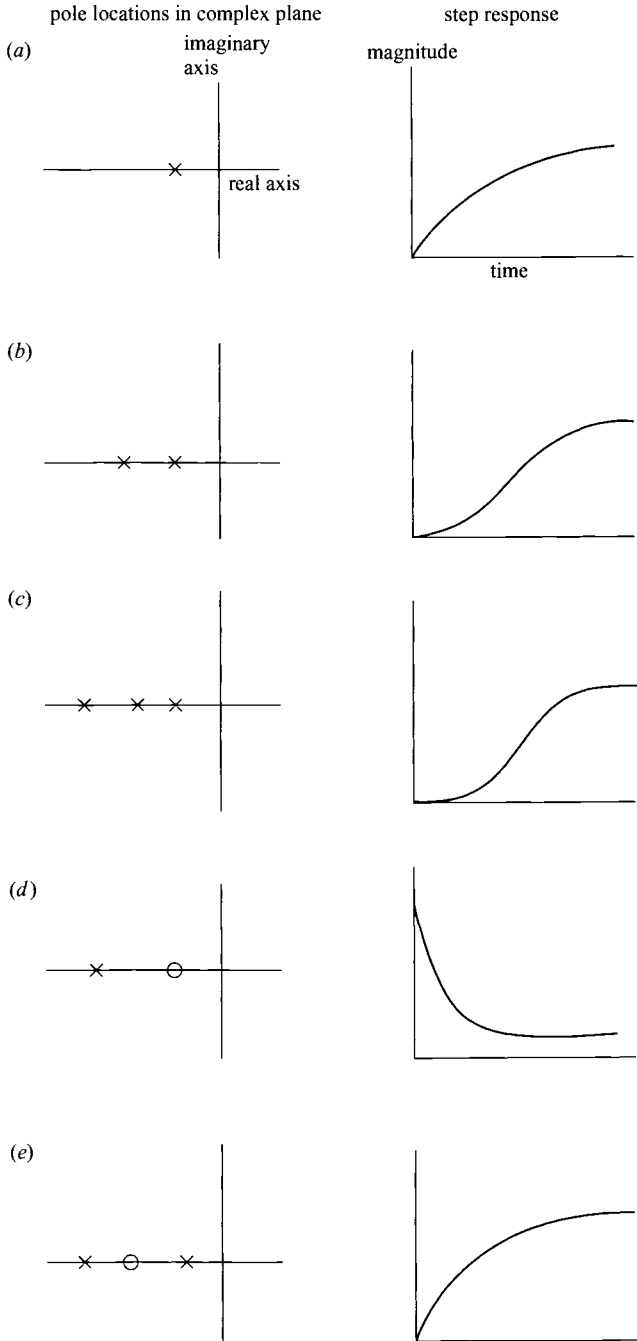

Figure 4.8 Continued

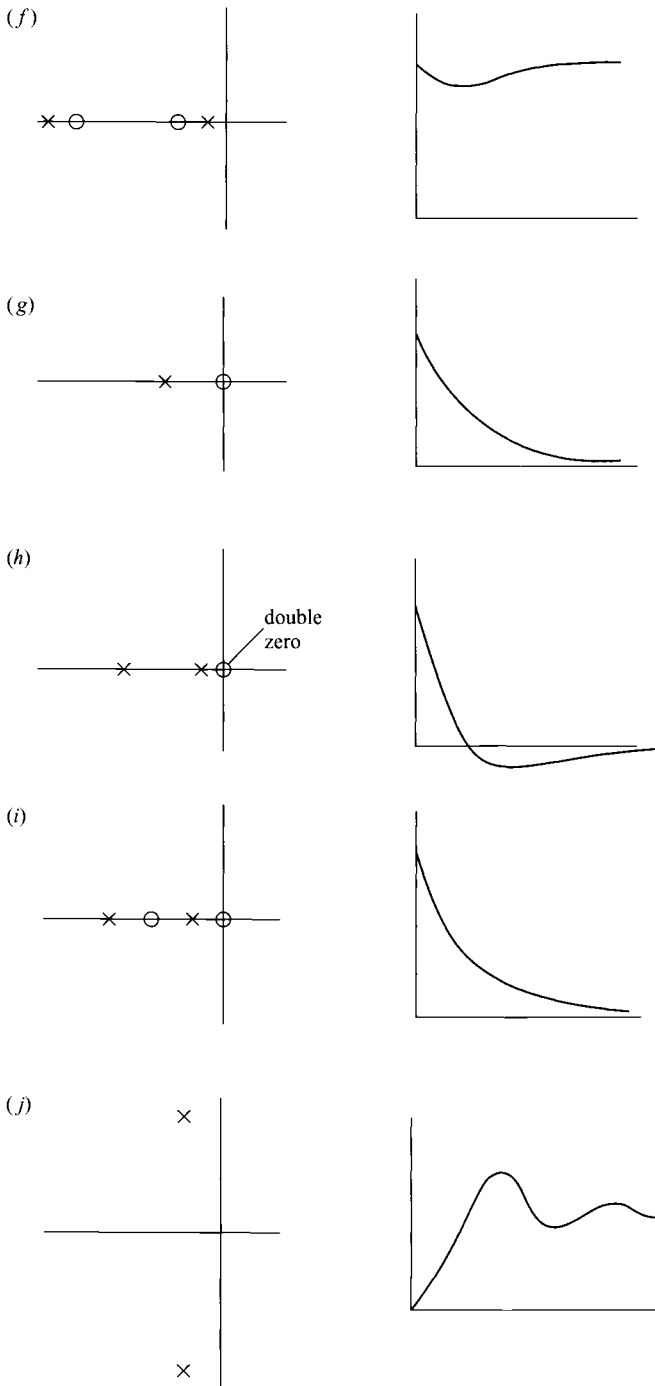

Figure 4.8 Examples of pole-zero diagrams and their associated step responses

4.9 Pole placement: synthesis of a controller to place the closed loop poles in desirable positions

Suppose a given system G has poles as shown in Figure 4.9, but it is required that the poles are actually at the positions shown in Figure 4.10. Then, preceding the given system by an element D having pole-zero diagram Figure 4.11 will cancel the poles of G and produce the required poles. This technique is called pole-placement.

Notice carefully that the unwanted poles of G are not removed – rather their effect on the external behaviour is cancelled out by the zeros of D .

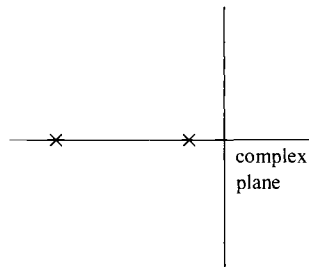

Figure 4.9 *Presumed initial position of system poles*

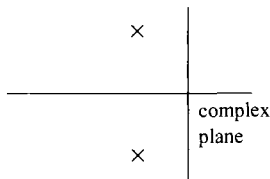

Figure 4.10 *The required position of the system poles*

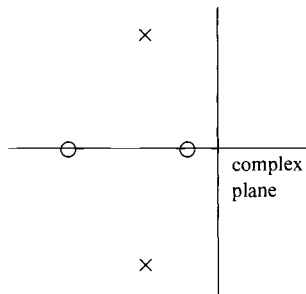

Figure 4.11 *Poles and zeros of a synthesised system (controller) that when connected in series with G will 'move' the poles to the required positions*

Two difficulties can arise when pole cancellation is used.

- (i) Cancellation may not be exact, or, if initially exact, may not remain so. This is particularly important where the poles whose cancellation is intended are unstable poles.
- (ii) A system in which poles have been cancelled out by coincident zeros only appears to have a simple form. Internally, the structure representing the cancelled terms is still present although it does not affect, nor can it be affected by, outside events. The redundant internal structure leads to difficulties and anomalies, particularly in those cases where matrix techniques are to be applied. This topic is discussed again in Sections 7.10, 7C and 7D.

4.10 Moving the poles of a closed loop system to desirable locations – the root locus technique

Consider the transfer function system (Figure 4.12):

$$G(s) = \frac{C}{(s + 1)(s + 3)}$$

which has poles at $s = -1, s = -3$. If the same system is connected in a closed loop (Figure 4.13) then, as shown in Section 4.5, the overall transfer function for the configuration is

$$\begin{aligned} \frac{G(s)}{1 + G(s)} &= \frac{C}{(s + 1)(s + 3)} \bigg/ \left(1 + \frac{C}{(s + 1)(s + 3)} \right) \\ &= \frac{C}{(s + 1)(s + 3) + C} \end{aligned}$$

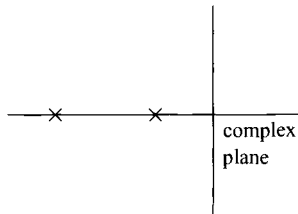

Figure 4.12 Poles of $G(s) = C/[(s + 1)(s + 3)]$

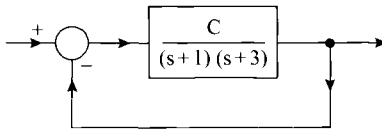

Figure 4.13 $G(s)$ connected into closed loop

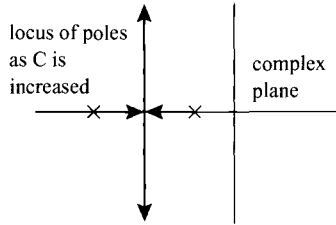

Figure 4.14 A root locus diagram for $G(s)$, showing how the closed loop poles move with increasing values of C

The poles of the closed loop configuration are found by equating the denominator of the transfer function to zero. In this case, the equation to be solved is

$$(s + 1)(s + 3) + C = 0$$

The solutions are $s = -2 \pm \sqrt{1 - C}$.

For $C < 1$ the poles are real, unequal

$C = 1$ the poles are real, equal

$C > 1$ the poles are complex conjugates.

A diagram (see Figure 4.14) showing how the poles move with changing C is called a root locus diagram. With the aid of the root locus diagram, we can decide on the value of C that will result in the closed loop poles being in desirable positions in the complex plane. Chestnut and Mayer (1959), chapter 13, has many examples of root locus configurations. More recent references, such as Dorf (2001), do not go into such detail but will be adequate for many purposes.

4.11 Obtaining the transfer function of a process from either a frequency response curve or a transient response curve

A frequency response curve is a curve that illustrates how a system's steady state response to sinusoidal signals varies as a function of the frequency of those signals (frequency response is discussed in Chapter 5).

A transient response curve is a curve that records a system's behaviour as a function of time immediately after the application of a stimulus to the system.

A non-minimum phase system is a system whose transfer function has one or more zeros in the right half complex plane (the reasons for the name and some discussion can be found in Chapter 7).

Experimental tests may produce frequency response curves or transient responses and these may need conversion to transfer functions to start design in the pole-zero domain. (Truxal (1955), p. 345 *et seq.*, has a masterly and detailed treatment of these topics – highly recommended.)

(1) Obtaining a transfer function from a given frequency response curve

The subject of filter synthesis tackles the problem in great detail (Guillemin (1957)). However, for control purposes, the problem is simpler and, in particular, a transfer function that has the desired magnitude response is likely also to have the desired phase angle characteristics. (In fact, for minimum phase transfer functions, the phase characteristic is completely determined by the gain characteristic [see HW Bode cited in Truxal (1955), p. 346].)

Thus if the magnitude characteristic can be approximated by straight line segments, then an approximate transfer function may be quickly produced using (inversely) the rules for straight line sketching of Bode diagrams (Dorf, 2001).

(2) Obtaining a transfer function from a transient response curve

Let the test signal be $u(t)$ and the resulting transient response be $y(t)$, then the transfer function

$$G(j\omega) = \frac{\mathcal{F}\{y(t)\}}{\mathcal{F}\{u(t)\}}$$

where \mathcal{F} indicates Fourier transformation.

In the days of ‘hand computation’, ingenious methods were devised to approximate the necessary Fourier transformation. Some of these methods are still of interest since they give insight into how the shape of a transient curve actually carries the transfer function information. For instance, Guillemin’s technique (see Truxal (1955), p. 379) involves approximation of the transient response by segments of polynomials, followed by repeated differentiation, resulting in a finite set of impulses from which the transfer function is written by inspection.

4C Convolution – what it is

Let the system of transfer function $G(s)$ have the response $g(t)$ to a unit impulse (Figure 4.15). The response to any other sort of input can then be visualised as the response to a train of impulses that approximates the function (Figure 4.16).

Any one of the individual impulse response curves in Figure 4.16c can be expressed as $u(\tau)g(t - \tau)$, where τ is the time of application of the impulse. Linearity allows us

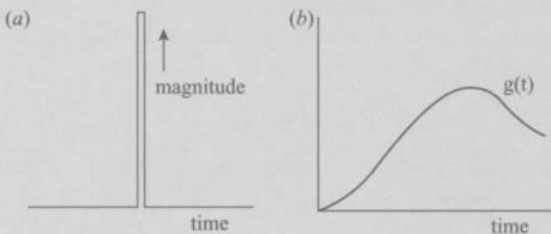

Figure 4.15 a A unit impulse at $t = 0$
b The response $G(t)$ of a system to a unit impulse

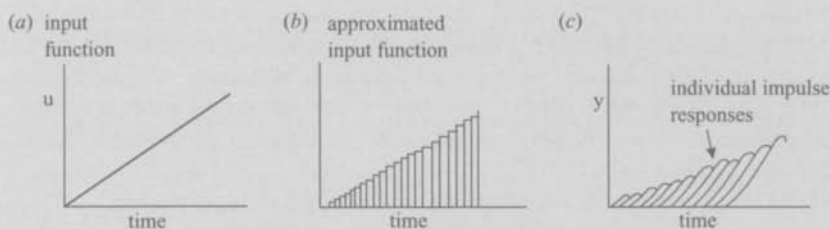

Figure 4.16 a A ramp input
 b A ramp input approximated by impulses
 c The response of a system to the individual impulses of (b)

to say that

$$y(t) = \int_0^t u(\tau)g(t - \tau) d\tau$$

and this expression, unpopular amongst students, is called the convolution integral.

We can avoid convolution or, more correctly, allow the Laplace transform to take care of it, as follows:

$$\text{Let } y(t) = u(t) * g(t)$$

where $*$ indicates convolution.

Then, by the properties of Laplace transforms

$$y(s) = u(s)G(s)$$

and

$$y(t) = \mathcal{L}^{-1}\{u(s)G(s)\}$$

In other words, transform multiplication corresponds to convolution of time functions.

To complete the discussion, we illustrate the use of the transform method to calculate the response of a system to a stimulus.

Let the system have the impulse response $g(t) = \exp(-t)$ (this implies $G(s) = 1/(s + 1)$), and assume the input u is a ramp function, i.e. $u(t) = t$, implying $u(s) = 1/s^2$. Then

$$y(t) = \mathcal{L}^{-1} \left\{ \frac{1}{s^2(s + 1)} \right\} = \mathcal{L}^{-1} \left\{ \frac{1}{s^2} - \frac{1}{s} + \frac{1}{s + 1} \right\}$$

(obtained by the use of partial fractions). Finally, inversion produces

$$y(t) = t - 1 + e^{-t}$$

4.12 Determination of transfer functions by cross-correlation

The cross-correlation of functions $u(t)$ and $y(t)$ is given by

$$R_{uy}(\tau) = \lim_{T \rightarrow \infty} \frac{1}{2T} \int_{-T}^T u(t - \tau)y(t) dt$$

If u is the input and y the corresponding output of a system G , then

$$y(t) = \int_{-\infty}^{\infty} g(\tau)u(t - \tau) d\tau$$

And after combination of the two expressions and some manipulation, we obtain

$$R_{uy}(\tau) = \int_{-\infty}^{\infty} g(x)R_{uu}(\tau - x) dx$$

where R_{uu} is the autocorrelation function of the signal u .

Under the special condition that the signal $u(t)$ is white noise, whose autocorrelation function is an impulse, the cross-correlation function $R_{uy}(\tau)$ is the system's impulse response and the Fourier transform or Laplace transform of this function is the system's transfer function.

4D Calculation of resonant frequencies from the pole-zero diagram

System responses can be calculated from the pole-zero diagram using approaches that are well described in, for example, Maddock (1982). These approaches are not really competitive as numerical algorithms but they can be very instructive. Thus, Figure 4.17 has been drawn to illustrate resonance in a second order system – resonance occurs when the product ab of the lengths a , b in the figure is a minimum as the arbitrary point p on the vertical axis (representing frequency) is varied. The calculation for the minimum value is carried out beneath the diagram, resulting in a formula for the resonant frequency.

We define

$$J = (r^2 + (h - w)^2)(r^2 + (h + w)^2)$$

Resonance occurs when ab is minimum, i.e. when $(ab)^2 = J$ is minimum:

$$\begin{aligned} \frac{dJ}{dw} &= (r^2 + h^2 - 2hw + w^2)(2h + 2w) \\ &\quad + (-2h + 2w)(r^2 + h^2 + 2hw + w^2) \\ &= r^2 + w^2 - h^2 \end{aligned}$$

Thus, the resonant frequency ω_r must satisfy

$$\begin{aligned} \omega_r^2 &= h^2 - r^2 \\ \omega_r &= (h^2 - r^2)^{1/2} \end{aligned}$$

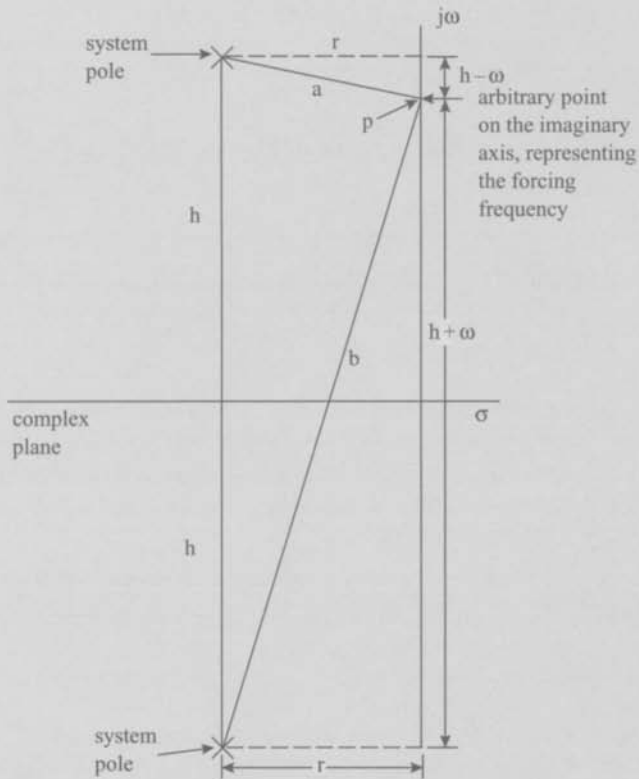

Figure 4.17 Construction in the complex plane for the graphical determination of resonant frequency

Now, damping factor ζ satisfies

$$r = \omega_n \zeta \text{ (since } \omega_n \text{ is a vector from origin to pole)}$$

$$h = \omega_n \sqrt{1 - \zeta^2}$$

hence

$$\omega_r^2 = -\omega_n^2 \zeta^2 + \omega_n^2 (1 - \zeta^2)$$

from which

$$\omega_r = \omega_n \sqrt{1 - 2\zeta^2}$$

4E Derivation of a formula for damped natural frequency

Following the application of a step input, the output of a stable system having a pair of complex poles oscillates at a frequency ω_d within a decaying exponential envelope. ω_d is called the damped natural frequency. Let p be a vector from the origin of the complex plane to one of the system poles, then (see Figure 4.18).

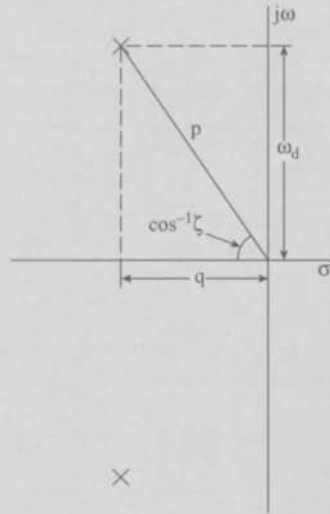

Figure 4.18 Construction in the complex plane for the determination of damped natural frequency

Undamped natural frequency ω_n is numerically equal to the length of the vector p . Damping factor ζ is the cosine of the angle that the vector p makes with the negative real axis.

Damped natural frequency is given by the length of the projection of the vector p onto the imaginary axis.

Then referring to Figure 4.18,

$$p^2 = q^2 + \omega_d^2$$

and

$$q = \omega_n \zeta, \quad p = \omega_n$$

therefore

$$\omega_d^2 = \omega_n^2 - \omega_n^2 \zeta^2$$

$$\omega_d = \omega_n \sqrt{1 - \zeta^2}$$

4F The root locus of a system with open-loop poles and zeros located as in Figure 4.19 will include a circle centred on the zero

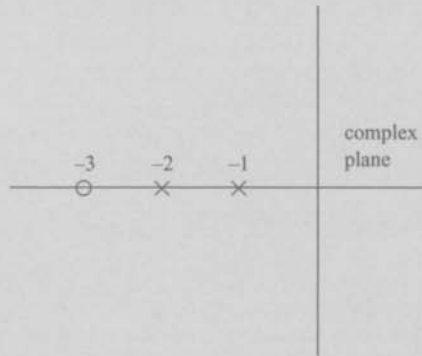

Figure 4.19 The pole-zero diagram of the second order system under study in this section

The closed loop transfer function of the system shown in Figure 4.19 is

$$\frac{C(s+3)}{(s+1)(s+2)+C(s+3)}$$

or (for ease of manipulation), putting $s = p - 3$, to move the origin to the point $s = -3$. The characteristic equation is

$$p^2 + (C - 3)p + 2 = 0$$

This is the equation of a circle, centre $(-3, 0)$, radius 2. To appreciate this, solve the characteristic equation, obtaining

$$R(p) = \frac{3-C}{2}, \quad I(p) = \sqrt{2 - \left(\frac{3-C}{2}\right)^2}$$

$$\sqrt{R(p)^2 + I(p)^2} = \sqrt{2}$$

Here R , I denote real and imaginary part respectively.

Chapter 5

Frequency response methods

5.1 Introduction

Frequency response methods have a physical explanation that is readily understandable without any mathematics. In addition the methods are design-oriented, link easily between practical results and differential equation methods, and have been proven to work well in many practical design situations.

The ‘home territory’ for frequency response methods has traditionally been in servo-mechanism, process control and aerospace applications, and they have been rather resistant to applications outside these areas.

5.2 Design using frequency response methods – initial explanation

Frequency response methods have a distinguished history with Harold Nyquist (1932) and Harold Bode (1945) being credited with early fundamental work that remains relevant.

Control design in the frequency domain involves the following basic ideas:

- (i) The performance of a system H that is to be synthesised may be approximately characterised by its bandwidth, i.e. by the range of frequencies to which it will respond.
- (ii) The bandwidth of any process G that is to be controlled may be measured experimentally or calculated analytically by straightforward means.
- (iii) The necessary frequency characteristics of a controller D may be determined graphically from information on G and H , such that the performance in (i) is obtained.
- (iv) Sufficient stability of the resulting control loop is easily taken care of as part of the design method.

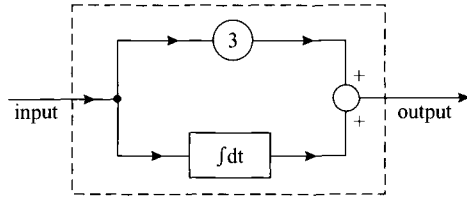

Figure 5.1 A linear system consisting of a gain and integrator

5.3 Frequency response of a linear system

A linear dynamic system consists mathematically of the (repeated) operations: multiplication by a constant, differentiation, integration and summation, and of no other types of operation. Therefore the response of a linear system to a sinusoid must necessarily be also sinusoidal; wave shape and frequency both being invariant under linear transformation.

Illustration: A linear system has the configuration shown in Figure 5.1. The input to the system is multiplied by a gain of 3 in the upper arm. It is integrated in the lower arm and the two signals are added to become the output. Thus, if the input is a sinusoid of unit amplitude and frequency $\frac{1}{4}$ rad/s (i.e. the input is the signal $\sin \frac{1}{4} t$) then the output will be

$$\begin{aligned}
 3 \sin t/4 + \int \sin t/4 dt &= 3 \sin t/4 - 4 \cos t/4 \\
 &= 5 \left(\frac{3}{5} \sin t/4 - \frac{4}{5} \cos t/4 \right) \\
 &= 5 (\cos \alpha \sin t/4 - \sin \alpha \cos t/4) \\
 &= 5 \sin(t/4 - \alpha)
 \end{aligned} \tag{5.1}$$

where $\alpha = \cos^{-1} \frac{3}{5}$, and we confirm that the signal remains sinusoidal of the original frequency, but that the amplitude has changed and that there is a phase shift α between input and output sinusoids.

By the frequency response of a system we mean a table or graph showing the output amplitude and phase difference, as a function of frequency, when a sinusoid of unit amplitude is applied to the system (it being assumed that all transient effects have died away before output measurements are taken).

5.4 The Bode diagram

The Bode diagram allows frequency response information to be displayed graphically. The diagram (Figure 5.2) consists of two plots, of magnitude and phase angle, both against frequency on the horizontal axis.

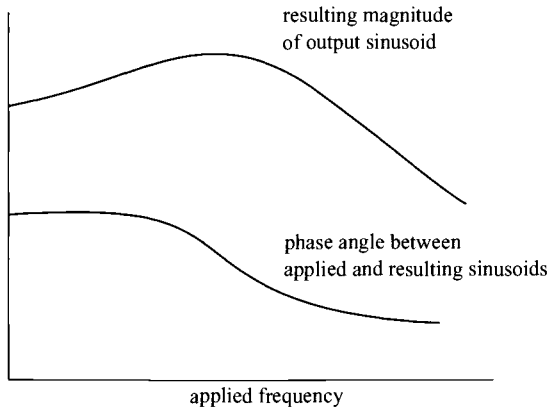

Figure 5.2 The form of a Bode diagram

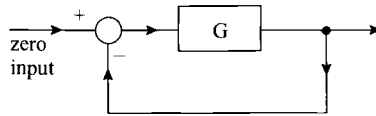

Figure 5.3 A block of transfer function G with unity feedback

5.5 Frequency response and stability: an important idea

If, for some particular frequency ω , the block G has unity gain and -180° phase shift, then the closed loop system shown in Figure 5.3 will be in continuous oscillation at frequency ω .

Explanation: A sinusoid of frequency ω , once input to the block G , will be subjected to two phase shifts of 180° (one at G , one at the comparator [multiplication by -1 and phase-shifting by 180° having the same effect on a continuous sinusoid]) and will pass repeatedly around the loop without attenuation, since the loop gain at frequency ω is unity.

In practice, special log-linear axes are used for Bode diagrams with frequency on a logarithmic scale and magnitude not plotted directly but only after conversion to decibels (dB). Under these special circumstances, the Bode plots for magnitude for most simple transfer functions can be approximated by straight line segments. In the logarithmic domain, products of transfer functions are replaced by summations of individual logarithmic approximations. Hence the Bode diagram magnitude characteristic for a moderately complex transfer function can easily be produced by summing a few straight line approximations.

The Bode diagram's popularity derives from the ease with which it may be sketched, starting from a transfer function; the ease with which it may be obtained by plotting experimental results; and from its usefulness as a design tool.

Implication: For stability of the closed loop system shown in Figure 5.3, at that frequency where the phase shift produced by G is -180° , the loop gain must be less than unity. Notice that the stability of the complete closed loop is being inferred from frequency response information referring to the block G alone.

5.6 Simple example of the use of the foregoing idea in feedback loop design

Block G of Figure 5.4a has the frequency response shown graphically in Figure 5.4b. Choose the largest numerical value for the gain C , consistent with stability of the loop of Figure 5.4c.

At the frequency where the phase shift of block G is -180° , the gain of G is 0.5, i.e. G multiplies sinusoids by a factor of 0.5 at that frequency. Thus it is clear that the gain C could be set to $C = 2$ to bring the system to the stability limit. (The gain C affects only amplitude – it has no effect on the phase shift curve.)

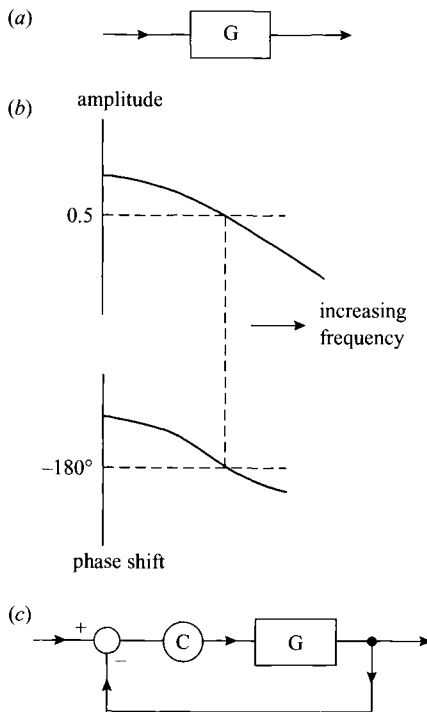

Figure 5.4 a A block of transfer function G
 b The frequency response of G
 c The gain C in the loop is to be set to the highest possible value, consistent with stability of the loop

5.7 Practical point – the need for stability margins

The gain C cannot in practice be set to the stability limit – rather C must be set so that a *stability margin* is observed. This ensures that, even allowing for the inevitable variations in all real systems, stability will still obtain. Further, the type of response to inputs other than sinusoids will then not be too oscillatory, as would be the case were the loop gain set at the stability limit.

5.8 General idea of control design using frequency response methods

Control design in the frequency domain is quite a specialist subject, requiring considerable experience and detailed knowledge. However, in principle, what is involved is, in addition to the original process, a compensator D , and, as before, a gain C , to be chosen (see Figure 5.5).

Treating GD as a pseudo-process, the choice of gain is made exactly as before. By suitable choice of the compensator D , systems satisfying particular specifications can be built up. In particular, systems with a flat frequency response up to a given frequency may be specified. Alternatively, undesirable resonance peaks in the frequency response for G may be cancelled out by proper choice of D .

Suppose that G is an existing process, like an electromechanical rotating device whose position is to be controlled. D is a controller, to be designed, which can contain frequency sensitive elements. C is, as before, a simple numerical gain.

The problem is: Design D and choose C to obtain a closed loop system having high bandwidth. The frequency response of the block G is supposedly known (it has been measured or calculated).

Procedure: Design D so that G and D , taken together, have a phase characteristic that reaches -180° at a much higher frequency than was the case for G alone, then choose the gain C so that the necessary stability margin is obtained.

In principle: A controller (or compensator) D is being used to modify the phase characteristics of G in such a way that a high gain C can be used without incurring

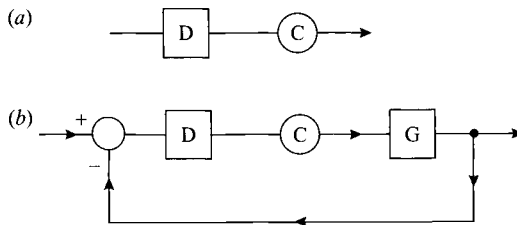

Figure 5.5 a A compensator D in series with a gain C
 b The combination of (a) in position to control the process G

stability problems. Such a high loop gain brings the high loop bandwidth desired by the designer.

5.9 Obtaining the frequency response of a system experimentally – a list of difficulties

A frequency response analyser makes the work easy since this device generates the necessary sinusoids, measures the responses and produces digital displays and plots of amplitudes and phase angles. Some of the difficulties encountered in practice are:

- Industrial processes are often already operating in ‘some sort of closed loop arrangement’ and it is not possible to isolate such processes for testing.
- Industrial processes, in some cases, cannot be considered to exist separately from the product being produced – managers may not take kindly to sinusoidal variations being induced into the products.
- Testing takes a very long time if low frequencies are involved. This applies particularly to large processes which tend to operate in the low frequency end of the spectrum.
- Electromechanical systems tend to move in a series of jerks when confronted with very low frequency signals. They tend to move erratically, giving inconsistent results, for high frequencies. Both effects can be attributed to the presence of non-linearities. Usually stiction is the cause of the low frequency jerking phenomenon whereas backlash in mechanisms is the source of most high frequency erratic behaviour. (At high frequencies, attenuation is severe, drive signals are of small amplitude, and backlash becomes significant.)
- Systems whose output has a non-zero mean level (especially a mean level that follows a long term large amplitude ramp) are very difficult to deal with.

This daunting list should not be taken to imply that frequency response testing can never be applied successfully in practice! However, it is true that only a somewhat limited class of processes can be successfully tested. Many of these are in the aerospace field. For industrial processes, other approaches are often used.

5.10 Design based on knowledge of the response of a system to a unit step input

When an input signal of the form shown in Figure 5.4a is applied to a system, the resulting response is called the unit step response of the system (Figure 5.6). It can be shown that all the information contained in a system’s frequency response is also contained in the system’s step response. However, the following points should be noticed:

- (i) The step response of a process is very much easier to obtain than the frequency response (in some cases just switch it on!). Even industrial processes on which experimentation is forbidden can be persuaded to yield step response information.

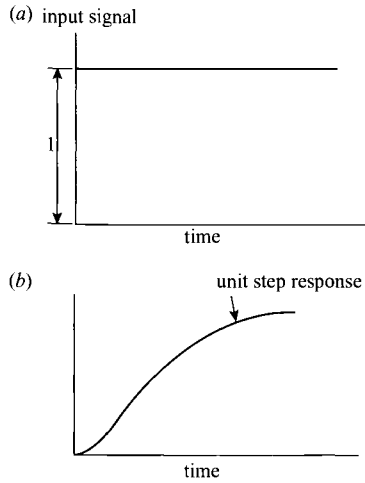

Figure 5.6 *a* The input to a system
b The output of the system in response to the input (*a*) is called the *unit step response* of the system.

- (ii) No very attractive design methods exist that use the step response as their input. However, the semi-empirical Ziegler–Nichols methods (one of which is based around an experimentally obtained step response) exist to allow the rapid tuning of coefficients in three-term controllers. Three-term controllers are the highly successful no-nonsense limited-ability devices that actually control a very high percentage of real industrial processes. See Section 8.3 for further information.
- (iii) Computer packages can very easily transform a system's step response into an equivalent frequency response. Thus, the easy-to-obtain step response can serve as an input to frequency-response-based design approaches. However, if such an approach is used, it is recommended to obtain several step responses corresponding to different input amplitude changes and to repeat these for negative going as well as for positive going input steps to ensure that asymmetry and non-linearity are discovered so that, if severe, these effects may be compensated for.

5.11 How frequency response is obtained by calculation from a differential equation

Suppose that a system is represented by the differential equation

$$\frac{dy}{dt} + ay = u \quad (5.2)$$

and that the input u is a sinusoidal signal $u = \delta \sin \omega t$. It is not difficult to solve the equation

$$\frac{dy}{dt} + ay = \delta \sin \omega t \quad (5.3)$$

using straightforward integration or Laplace transforms. For frequency response purposes, the transient part of the solution is not usually of interest and only the particular integral, describing the periodic behaviour, needs to be considered. Using the operator D method for this we obtain:

$$\begin{aligned} (D + a)y &= \delta \sin \omega t \\ y &= \frac{\delta}{D + a} \sin \omega t \\ &= \frac{\delta(D - a)}{D^2 - a^2} \sin \omega t \\ &= \frac{\delta(D - a)}{-\omega^2 - a^2} \sin \omega t \\ &= \frac{-\delta(D - a)}{\omega^2 + a^2} \sin \omega t \\ &= \delta \left(\frac{a \sin \omega t - \omega \cos \omega t}{\omega^2 + a^2} \right) \\ &= \frac{\delta}{\sqrt{\omega^2 + a^2}} \left(\frac{a \sin \omega t - \omega \cos \omega t}{\sqrt{\omega^2 + a^2}} \right) \\ &= \frac{\delta}{\sqrt{\omega^2 + a^2}} (\cos \alpha \sin \omega t - \sin \alpha \cos \omega t) \end{aligned}$$

where $\alpha = \tan^{-1}(\omega/a)$

$$\begin{aligned} &= \frac{\delta}{\sqrt{\omega^2 + a^2}} \sin(\omega t - \alpha) \\ &= m \sin(\omega t + \phi) \text{ (say)} \end{aligned} \quad (5.4)$$

Thus

$$m = \frac{\text{magnitude of output sinusoid}}{\text{magnitude of input sinusoid}} = \frac{1}{\sqrt{\omega^2 + a^2}}$$

$$\phi = \text{phase difference between input and output sinusoid} = -\tan^{-1} \omega/a$$

If we return to the transfer function of the original system,

$$G(s) = \frac{1}{s + a}$$

and obtain

$$G(j\omega) = \frac{1}{j\omega + a}$$

then we find that the magnitude m is the same thing as the modulus of the complex number $G(j\omega)$ while the phase angle ϕ is the argument of $G(j\omega)$. In other words, if $G(j\omega)$ is expressed in $R\angle\alpha$ form then $R = m$ and $\alpha = \phi$. These relations allow the frequency response of a transfer function to be calculated very simply by determination of the modulus and argument of a complex number as a function of frequency – there is no requirement (since these relations are available) to solve differential equations.

It can easily be demonstrated by simple examples that the substitution method, as just described, gives the same results as eqn. 5.4. The formal justification for setting $s = j\omega$ to obtain frequency response information from the transfer function can be as follows.

Let a process of transfer function $G(s)$ and having impulse response $g(t)$ receive as input the complex sinusoid $\exp(j\omega t)$. Then the steady state response y_{ss} can be found by convolution to be

$$\begin{aligned} y_{ss} &= \int_0^{\infty} g(\tau) \exp(j\omega(t - \tau)) d\tau \\ &= \exp(j\omega t) \int_0^{\infty} g(\tau) \exp(-j\omega\tau) d\tau \end{aligned} \quad (5.5)$$

Comparing the term under the integral sign with the defining equation for $G(s)$:

$$G(s) = \int_0^{\infty} g(\tau) \exp(-s\tau) d\tau \quad (5.6)$$

we see that

$$y_{ss} = \exp(j\omega t)G(j\omega) \quad (5.7)$$

i.e. the output is also the complex sinusoid of frequency ω but of magnitude $|G(j\omega)|$ and with phase difference (compared with the input) of $\angle G(j\omega)$.

5.12 Frequency response testing can give a good estimate of a system's transfer function

Assume that frequency response testing has produced the magnitude curve of Figure 5.7. Then it is clear by inspection that the system can be modelled by a transfer function of the form

$$G(s) = \frac{C}{(1 + sT_1)(1 + sT_2)}$$

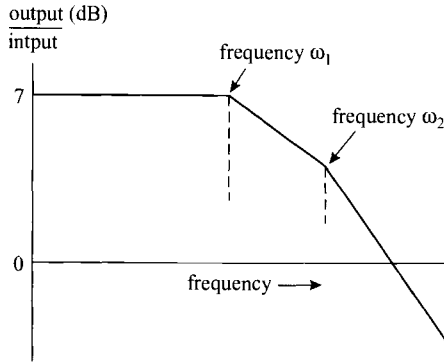

Figure 5.7 *The supposed frequency response (magnitude curve) of an unknown system*

where $T_1 = 1/\omega_1$, $T_2 = 1/\omega_2$ and $C = 10^{7/20}$ (to see this, sketch the form of the Bode plot for the given $G(s)$).

Questions to be asked about frequency response testing include:

- (i) On what proportion of real systems can meaningful frequency response tests be carried out?
- (ii) What proportion of successfully completed frequency response tests lead to an easily interpreted set of data?
- (iii) How often can a real control system be designed using an experimentally obtained frequency response model?
- (iv) Overall, roughly what proportion of real control systems are actually designed via these routes?

5.13 Frequency response of a second order system

A first order system is abnormally simple. The step response is exponential. The frequency response (magnitude) plot decays monotonically. Oscillation and resonance are not possible.

A second order system, although structurally simple, can in many ways be considered as a reliable idealisation of a whole class of systems of higher order. For instance, when trying to visualise a concept, it will often be sufficient to think of dynamic effects in terms of their second order approximation. For the reasons just given, it is very useful to understand the frequency response of a normalised second order system.

Every second order (linear) system can be converted into the standard form

$$\ddot{y} = 2\xi\omega_n\dot{y} + \omega_n^2y = \omega_n^2u$$

with transfer function

$$G(s) = \frac{\omega_n^2}{s^2 + 2\zeta\omega_n s + \omega_n^2}$$

Putting $s = j\omega$

$$G(j\omega) = \frac{\omega_n^2}{\omega_n^2 - \omega^2 + j2\zeta\omega_n\omega}$$

$$= \frac{1}{1 - (\omega/\omega_n)^2 + j2\zeta(\omega/\omega_n)}$$

we can obtain universally useful Bode diagrams of the plot against ‘dimensionless frequency’ ω/ω_n . Such plots follow as Figures 5.8a and b.

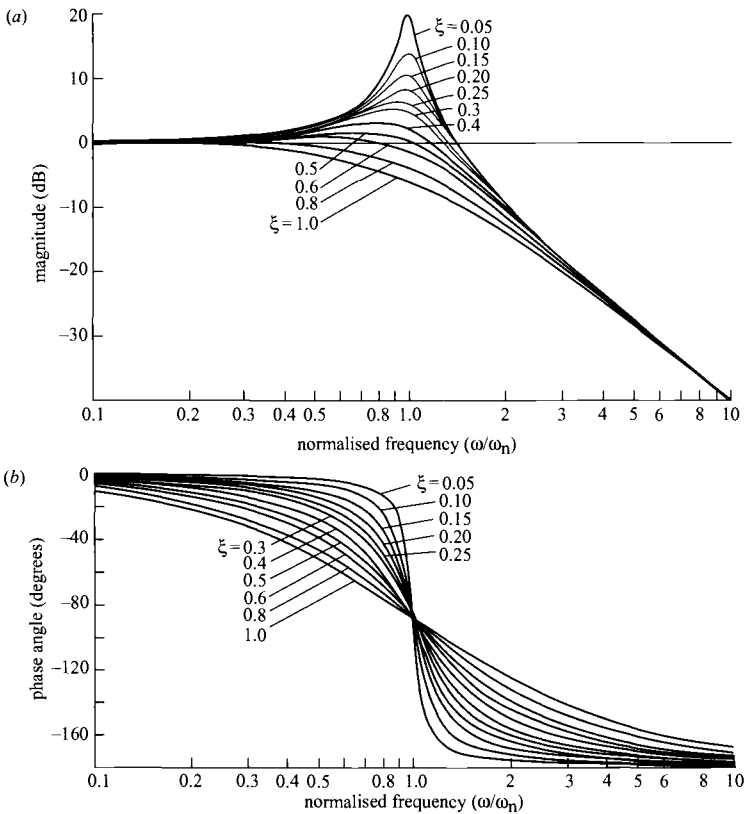

Figure 5.8 Frequency response for a second order system with different damping factors ζ

- a Magnitude curve
- b Phase curve

5A The frequency response of a system with poles and/or zeros near to the imaginary axis

A system has the poles and zeros shown in Figure 5.9a. As the applied frequency moves up the imaginary axis there will be a notch in the magnitude response as the zero is passed and a peak as the pole is passed. The magnitude plot of frequency response will have the approximate form of Figure 5.9b (see Harris (1961), p. 152 for further details).

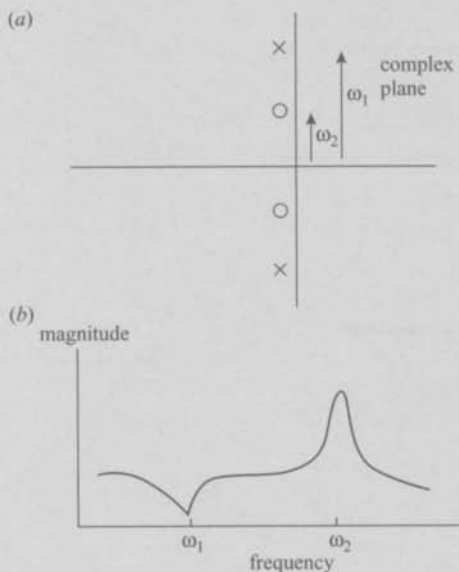

Figure 5.9 a A pole-zero diagram in which the poles and zeros are close to the imaginary axis
 b The form of the (magnitude) frequency response corresponding with (a)

5B Some interesting and useful ideas that were originated by Bode

Bode (1945) showed that (provided non-minimum phase systems are excluded) the magnitude and phase characteristics are totally interdependent. That is to say, given a magnitude characteristic for a Bode diagram, then the phase characteristic is completely determined and conversely. The following is based directly on Chestnut and Mayer (1959), which should be consulted for additional detail.

Bode's theorem 1 states, retaining his original notation: the phase shift of a network or system at any desired frequency can be determined from the slope of its attenuation/frequency characteristic over the range of frequencies from $-\infty$ to $+\infty$. The slope

of the attenuation/frequency characteristic at the desired frequency is weighted most heavily, and the attenuation/frequency slope at frequencies further removed from the desired frequency has lesser importance:

$$B(\omega_d) = \frac{\pi}{2} \left. \frac{dA}{du} \right|_0 + \frac{1}{\pi} \int_{-\infty}^{+\infty} \left[\left. \frac{dA}{du} \right| - \left. \frac{dA}{du} \right|_0 \right] \ln \coth \left| \frac{u}{2} \right| du \quad (5.8)$$

where

$B(\omega_d)$ = the phase shift of the network in radians at the desired frequency ω_d ,

A = attenuation in nepers where 1 neper = $\ln |e|$.

This curve provides a valuable insight into the relation between magnitude and phase characteristics (Figure 5.10).

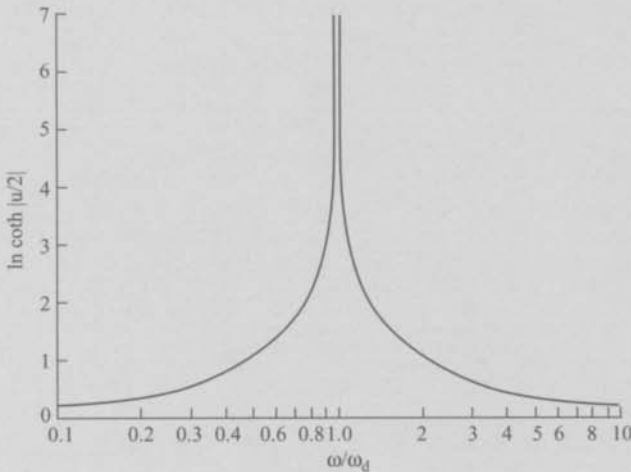

Figure 5.10 Weighting function for use with eqn. 5.8 where $u = \ln \omega/\omega_d$.

In most situations, the phase shift is determined largely by the first term of eqn. 5.8. From this point of view it appears that, for the phase shift to be less negative than -180° at frequencies in the vicinity of the $-1 + j0$ point, the attenuation slope should be less than 2 nepers per unit of u or less than 40 dB per decade over a fairly broad range of frequencies.

The following simple and very useful rule (again due to Bode and verifiable from the material given above) allows stable systems to be synthesised using only the magnitude plot:

'A system will be stable if the slope of the Bode magnitude plot in the region of 0 dB is -20 dB/decade and if this shape is maintained for a region of ± 0.5 decade about the 0 dB crossing point.'

This simple rule is only approximate and it is indeed rather conservative. However, it is a very useful rule for making a first cut design (Truxal, 1955, p. 46).

5.14 Nyquist diagram and Nichols chart

The information in a Bode diagram may be represented in alternative forms. Representation in polar coordinates results in the *Nyquist diagram* – this is a locus in the complex plane with frequency being a parameter on the locus.

The Nichols chart is a plot of magnitude against phase angle. This diagram is again a locus along which frequency appears as a parameter. The Nichols chart is used with a special overlay that assists control design.

The Bode diagram, Nyquist diagram and Nichols chart form a complementary set in the armoury of the frequency-response-oriented system designer. There is a very extensive literature.

Chapter 6

Mathematical modelling

6.1 Approaches to mathematical modelling

Figure 6.1 shows a general situation that is to be modelled. External influences (controls, raw material characteristics, environmental influences and disturbances) are contained in vector u . Available information (measurements, observations, other data) are contained in vector y . The vector x contains internal variables fundamental to the situation. x may be of no interest whatever, except as a building block to the modeller. Alternatively, x may be of great interest in its own right. We assume that there are available data sets $\{u_i, y_i\}$ for the modeller to work on.

Approach (1) is to fit numerically a dynamic linear input–output model G_i to each data set $\{u_i, y_i\}$. This is very easy but:

- (i) G_i may not fit the data well for any i . Such an effect may be encountered when the situation is non-linear and/or time varying.
- (ii) Different data sets (u_j, y_j) , (u_k, y_k) that are supposed to arise from the same mechanism may give rise to widely differing models G_j, G_k .
- (iii) Non-standard types of information, contained within the vectors u_i, y_i may be impossible to accommodate within a standard identification procedure.

Approach (2) is to construct a set of interlinked physically inspired equations, involving the vector x , that approximate (possibly grossly) the mechanisms that are thought to hold in the real process.

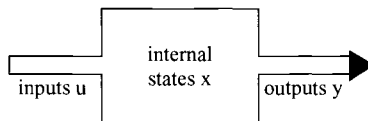

Figure 6.1 A general situation that is to be modelled

The data sets $\{u_i, y_i\}$ are then used quantitatively to fix numerical values for any situation-specific coefficients and, when best values have been found, to verify the performance of the resulting model.

Approach (3) is to fit an empirical black-box model, typically a neural network, to as wide a range of input–output data as possible in the hope of obtaining a single non-linear relation that represents all the cases presented. The expectation is that the behaviour of the model so obtained will generalise sufficiently well to act as a useful model of the process. Neural net modelling is discussed in Section 17.2.

6.2 Methods for the development of mathematical models

Whereas control theory is a fairly coherent well-defined body of concepts and knowledge, supported by techniques, the activity of mathematical modelling is ill-defined and its practitioners are scattered amongst many disciplines. Thus, in science, models are often used to explain phenomena as, for instance, the Bohr model of the atom or the wave theory of electromagnetic propagation. Such models are essentially visualisations of mechanisms. Far removed from this are those models, usually implicit and sometimes fictitious, by which politicians claim to predict future rates of employment or inflation.

We can propose that the science models contain – and this is their fundamental characteristic – a representation of physical variables. The second group may be, in the extreme, no more than extrapolations of past trends. Constructing a model in the first category is primarily a matter of bringing together, combining and refining concepts to produce an object called a model (usually it will consist of a set of equations).

A key question that needs to be answered is: How universally valid is the model required to be?

6.3 Modelling a system that exists, based on data obtained by experimentation

A system that exists may be able to produce data from which a model can be constructed. The ideal situation is one where:

- (a) The system is available for experimentation with no limits on the amount of data that can be acquired.
- (b) The system receives no other signals than those deliberately injected by the experimenter.
- (c) The system is, to a reasonable approximation, linear and time invariant.
- (d) The system completes its response to a stimulus within a reasonable time scale.
- (e) The system has no ‘factors causing special difficulty’.
- (f) It is not intended to use the model outside the region of operation spanned by the experiments.
- (g) The physical meaning of the model is not of interest.

- (h) The only system that is of interest is a unique one, on which the experiments are to be made.

This is a formidable list. It shows why modelling based on experimentation is so difficult. Discussing the points in turn:

- (a) Real (for instance, industrial) systems are almost never available for experimentation. This is why pilot plants and laboratory-scale systems are commonly used – unfortunately they are often quite different from large systems in their behaviour with such differences themselves being very difficult to quantify. For this reason, simulations of systems are often used in preference to pilot plants, but of course simulations need system models . . . However, real systems may usually be observed under normal operating conditions and models may be developed based on the resulting data.
- (b) Real systems will usually be subject to operational inputs and unmeasurable disturbances, in addition to any signals originated by the experimenter. The experimenter's signals will always need to observe amplitude constraints and there always arises the question: Is the signal-to-noise ratio of recorded data sufficient to allow modelling to proceed to a level of sufficient accuracy?
- (c) Real systems exhibit every sort of undesirable behaviour: Lack of repeatability, hysteresis and asymmetry are the norm.

Additionally, linearity fails for all systems in that increasing the amplitude of applied stimuli will fail eventually to provoke proportional responses. Linearity will often also fail at the other end of the amplitude range, in that, for signals of a sufficiently small amplitude, no output response may be obtained. All of these factors need to be considered when choosing the signals to be injected during an experiment that is specifically designed to produce data for modelling. (Such an experiment will be called an identification experiment.)

- (d) It will clearly be convenient if a complete identification experiment can be concluded within a few hours. This will not be possible if the system is very slow to respond to stimuli. The problem will be compounded if an identification method that requires long successions of test signals is used.
- (e) Problems in this category are often the most severe from a practical point of view. They include:
 - (i) Systems that cannot operate except under closed loop control. This situation complicates the identification procedure because some of the system input signals are dependent on the system output signals.
 - (ii) Systems where the only practically accessible signals are multiplexed sequential digital signals, often existing as part of a closed-loop control system as in (i).
 - (iii) Systems where a product forms an essential part of the system, such that experimentation without the product is meaningless and on a small scale is impracticable. Many industrial processes operate for very long runs and the most important control problems are often intimately linked with the production aspect. For instance, keeping thousands of loaves or steel bars

within specification for hour after hour is not something that can easily be emulated on a pilot scale plant.

- (iv) Systems where there are significant trends, i.e. when, in some sense, the mean level of operation changes markedly with time.
- (f) Identification may form part of a project that is intended eventually to move the system into a new operating regime. Clearly, a model based on data obtained in one operating region may have little or no validity in a different operating region.
- (g) The coefficients in an experimentally based model will owe more to the mechanics of curve fitting than to any physical aspects of the system. This aspect may limit the usefulness of the model since, for instance, it is not possible to estimate from the model the effect of a change in system configuration.
- (h) Development projects will often aim to design solutions for a class of systems (rather than for one particular given system). In such instances, it is important not to base global designs on models of only local validity.

6.4 Construction of models from theoretical considerations

A system can most easily be modelled when every aspect obeys established physical laws and where, additionally, all the required numerical coefficients are exactly known. Most usually, real systems have to be heavily idealised before textbook theories can be applied. Such idealisation naturally means that model and system differ appreciably.

Turning to numerical coefficients, these can be classified roughly into three groups:

- (i) Universal constants where values are exactly known.
- (ii) Coefficients whose role in the theoretical framework is well understood but whose numerical values may vary over a wide range depending on system configuration and prevailing conditions.
- (iii) Coefficients on whose numerical values the appropriate accepted theories have little or nothing to say.

6.5 Methods/approaches/techniques for parameter estimation

The methodology for mathematical modelling is as follows. Relevant theories are consulted to yield a tentative set of equations, in which some of the coefficients are unassigned. Data are recorded from particular systems and the coefficients in the equations are adjusted until the set of equations (the model) performs as closely as possible like the real world system – as judged by comparison between recorded system data and model-generated data. The comparison is made unambiguous by the definition of a scalar-valued criterion that is to be minimised by choice of model

coefficients. Automatic search for the best model coefficients is assisted by parameter estimation algorithms, often called informally, but accurately, hill-climbing methods.

These methods search for the minimum in the multidimensional and often ill-conditioned parameter space (ill-conditioned in the sense that the axes are in practice far from orthogonal and the function that is to be minimised often has narrow ridges on which an algorithm without ridge-following abilities may terminate its progress before reaching the minimum).

Figure 6.2 shows the scheme by which observations and model outputs are compared and the difference between them minimised by hill-climbing. Figure 6.3 illustrates the iterative search in parameter space performed by the hill-climbing algorithms.

Rarely, if ever, does the first attempt at modelling succeed in the sense that it produces an accurate usable model. Almost always alternative model structures have to be tried, hill-climbing repeated and the fit between model and reality re-examined, until eventually a sufficiently good model performance is obtained. During the modelling procedure, the misfits between model outputs and measured observations (often referred to as 'residuals') can be plotted to assist in decisions on model changes that

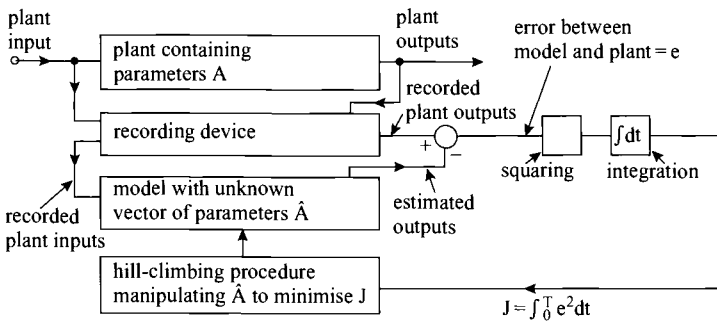

Figure 6.2 The principle of hill-climbing for the estimation of unknown model parameters

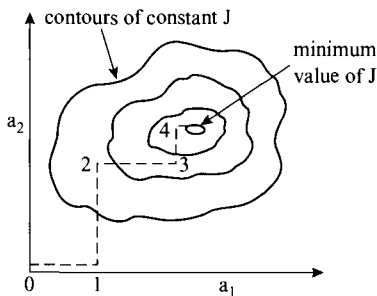

Figure 6.3 Visualisation of an iterative search in parameter space

might with advantage be made to further improve the fit. In principle, the residuals should contain no deterministic element and should have zero mean – if not, the implication is that there are still unmodelled deterministic features that should be incorporated into the next version of the model.

6.6 Why modelling is difficult – an important discussion

Let Σ be a class of system for which a model M is to be constructed. M is to have a theoretically based structure with experimentally determined numerical coefficients.

It is required that M should represent a large number of actual system examples S_1, S_2, \dots, S_n . To allow the experimental determination of numerical coefficients, sets of operating data are obtained from the i th system S_i .

Each of the different data sets from system S_i can be denoted $D_{ij}, j = 1, \dots$ and of course, different data sets D_{ij}, D_{ik} may represent nominally identical operating conditions of the system S_i , or they may happen to be different, or they may have been planned to be widely different especially to assist modelling.

With the aid of relevant theory, we select particular model structures M_α, M_β, \dots (such selection will always involve a compromise between oversimplification and overelaboration). Armed with one model structure M_0 and one data set D_{11} , we can use parameter estimation techniques to produce a best fit.

The key question is: to what extent is the model structure M_0 , with parameters determined from data set D_{11} , meaningful to represent the whole class Σ . It is clear that many data sets from different representative systems would need to be analysed before any claim to universality of models could be made.

The extreme difficulty that this problem represents can soon be appreciated if one thinks of particular examples. Consider, for instance, the modelling of the manufacturing of electronic devices or the modelling of biological growth processes (as required in the manufacture of penicillin). The choice of approach somewhere between theoretically based universality and a practically based one-off solution will depend on the intended use for the model.

A compromise solution to satisfy many short to medium term requirements is to find a general tried and tested piece of software that is intended to represent (say) a class of production processes, and then customise it by structural changes and parameter estimation on typical data to represent a particular situation (Figure 6.4).

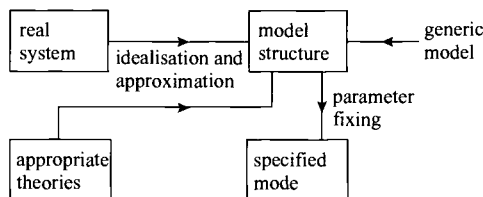

Figure 6.4 *The modelling procedure: the route from real system to specified model of that system*

6.7 Fixing of parameters

Clearly (see Sections 6.3(i), (ii), (iii)), some coefficients are universal constants and can be fixed for all time; others are specified by the theory to lie in a known band; for yet others there is no *a priori* indication of numerical value.

6.8 Parameter estimation

Parameter estimation is the activity of fixing numerical values in the generic model of the system to particularise it to a specific case. From what has already been said, it is obvious that coefficients on which there is no theoretical guidance will need to be specified either by ‘case law’ (i.e. experience from elsewhere) or by observation/experimentation.

6.9 Regression analysis (This section is based on Davidson (1965))

Suppose we assume a mathematical model relating a dependent variable y to a set of independent variables x_1, x_2, \dots, x_k

$$y = a_1x_1 + a_2x_2 + \dots + a_kx_k$$

The a_i are parameters whose values are to be determined from sets of repeated measurements that can be tabulated in the form:

$$\begin{array}{ccccccc} y_1 & x_{11} & x_{12} & \dots & x_{1k} & & \\ y_2 & x_{21} & x_{22} & \dots & x_{2k} & & \\ \vdots & \vdots & \vdots & & \vdots & & \\ y_n & x_{n1} & x_{n2} & \dots & x_{nk} & & \end{array}$$

or in vector–matrix notation,

$$[y|X]$$

where X is an $n \times k$ matrix. It is usually assumed that:

- (i) The measurements X have no error.
- (ii) The measurements y each have a random normally distributed error, with mean μ and variance σ^2 ; the variance is the same for all observations, and the errors of the y are statistically independent. There are two approaches to choosing the parameters a_1, a_2, \dots : Gauss’s criterion of least squares and Fisher’s criterion of maximum likelihood. Under the assumptions listed above, these two approaches lead to the same results.

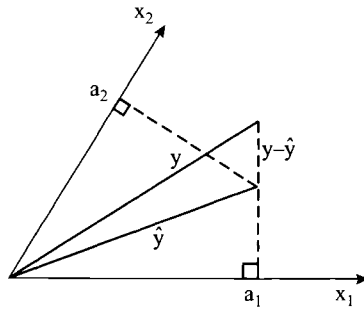

Figure 6.5 *The method of least squares considered as the projection of the observed vector onto a k -dimensional hyperplane*

Minimising the sum of squares between calculated and observed values for y involves solving the set of simultaneous linear equations

$$X^T X a = X^T y$$

leading to

$$a = (X^T X)^{-1} X^T y = C X^T y$$

As is shown by Davidson (1965), the method of least squares may be viewed geometrically as the projection of the observed vector $y \in \mathbb{R}^n$ onto the k dimensional observation hyperplane whose basis vectors are the columns of Xa . The projection of y onto the observation space is $\hat{y} \in \mathbb{R}^k$. Figure 6.5 illustrates the concept.

6.10 Analysis of residuals

In a perfect model, the residuals $y - \hat{y}$ display only a random error pattern. Plots of residuals are most valuable in highlighting systematic unmodelled elements. Figure 6.6 illustrates some of the types of plot that can assist the process of model development and refinement (from Davidson (1965)). Figure 6.6a shows the desirable pattern. Figures 6.6b to 6.6e illustrate various types of undesirable bias.

6A Doubt and certainty

An interesting fundamental question that arises in mathematical modelling is to what extent it is ever possible to claim that a particular model structure is correct. The following extract from Cormack (1990) is relevant:

'A theorem in mathematics starts and ends in the mind. Given the initial premises only logic is needed to reach the final answer. But problems arise when the argument starts,

not from axioms, but from sense data of the real world. More than one theory will account for the observations and logic may not, by itself, settle the question. In such a case, a well designed experiment may show which of two contradictory ideas is to be preferred.

'A scientific theory is accepted not because it is "true" whatever that may mean, but because it works and is useful. Some helpful rules have emerged. The prime test of a theory is that it should predict correctly. Secondly it must be consistent with the rest of science. It must have, as Einstein (French, 1979) put it, both "internal and external coherence". A crucial experiment never verifies the "correct" idea in any absolute

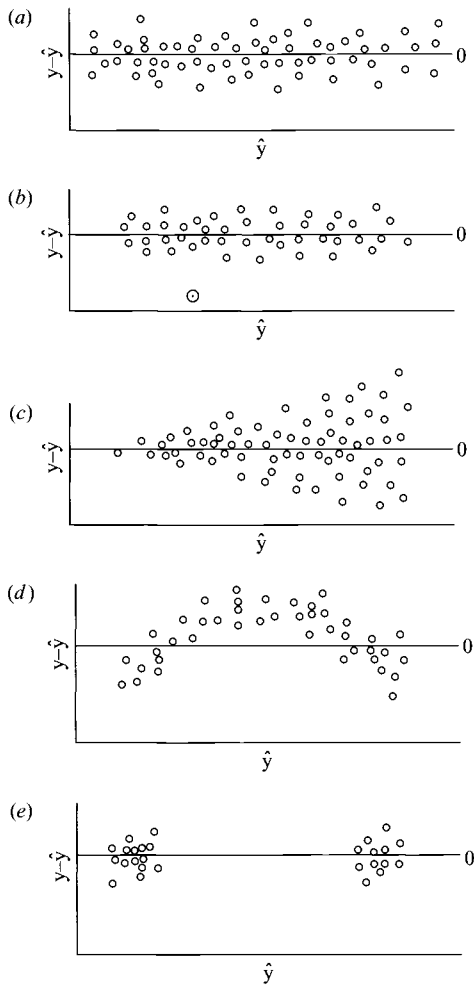

Figure 6.6 Possible plots of residuals (after Davidson, 1965)

sense; and also Einstein (French, 1979) "As far as the propositions of mathematics refer to reality they are not certain; as far as they are certain they do not refer to reality".'

6B Anticipatory systems

Anticipatory systems—defined as those systems which contain internal predictive models of themselves and/or of their environment, and which utilise the predictions of their models to control their present behaviour – are specially complex from the modeller's point of view (Rosen, 1985).

Systems of this type have a variety of properties which are unique to them, just as 'closed-loop' systems have properties which make them different from 'open loop' systems. It is most important to understand these properties, for many reasons. Rosen (1985) argues that much, if not most, biological behaviour is model-based in this sense. This is true at every level, from the molecular to the cellular to the physiological to the behavioural.

Rosen argues:

'An anticipatory system is one in which present change of state depends upon future circumstances, rather than merely on the present or past. As such, anticipation has routinely been excluded from any kind of systematic study, on the grounds that it violates the causal foundation on which all of theoretical science must rest, and on the grounds that it introduces a telic element which is scientifically unacceptable. Nevertheless, biology is replete with situations in which organisms can generate and maintain internal predictive models of themselves and their environments, and utilize the predictions of these models about the future for purpose of control in the present. Many of the unique properties of organisms can really be understood only if these internal models are taken into account. Thus, the concept of a system with an internal predictive model seems to offer a way to study anticipatory systems in a scientifically rigorous way.

'This approach raises new questions of a basic epistemological character. Indeed, we shall see that the utilization of predictive models for purposes of present control confronts us with problems relating to causality.

'The gadgeteers and data collectors, masquerading as scientists, have threatened to become the supreme chieftains of the scholarly world.

'As the Renaissance could accuse the Middle Ages of being rich in principles and poor in facts, we are now entitled to enquire whether we are not rich in facts and poor in principles.

'Rational thought is the only basis of education and research. Facts are the core of an anti-intellectual curriculum.

'One of the best-studied biological homeostats is one involved in maintaining an optimal constancy of light falling on the retina of the vertebrate eye, the so-called "pupillary servomechanism". Roughly speaking, in conditions in which there is a great deal of ambient light, the pupil contracts, and admits a smaller amount of light to the eye. Conversely, when the ambient light is dim, the pupil opens to admit more light. It has been established that the control system involved here is a true feedback system, whose output is represented by the actual amount of light falling on the retina.

Thus, the sensor for the controller is at the retina, and the system reacts to how much light has already been admitted to the eye. The time constant for this servomechanism is not outstandingly small, but the system clearly functions well for almost all conditions that the organism encounters.

'Now let us consider the analogous problem of controlling the amount of light entering a camera to ensure optimal film exposure. Here again, the control element is a diaphragm, which must be opened when the ambient light is dim, and closed when the ambient light is bright. However, in this case, we cannot in principle use a reactive mechanism at all, no matter how small its time constant. For clearly, if the input to the controller is the light falling on the film, in analogy to the situation in the eye, then the film is already under- or over-exposed before any control can be instituted. In this case, the only effective way to control the diaphragm is through an anticipatory mode, and that is what in fact is done. Specifically, a light meter is then referred to a predictive model, which relates ambient light to the diaphragm opening necessary to admit the optimal amount of light to the camera. The diaphragm is then preset according to the prediction of the model. In this simple example we see all the contrasting features of feedforward and feedback; of anticipatory as against reactive modes of control. [This note has been added by the author JRL: 'since those words were written, intelligent flashguns have become available that, working closely with a coupled camera, do work in feedback mode as follows. The lens is opened, the flash begins, light is reflected from the subject back into the lens to make the exposure and to be monitored and integrated by a through-the lens light meter. When calculation shows that exposure is complete, the flash is terminated. The extreme speed of light makes this remarkable feedback loop possible. To complete this discussion, I note that the Nikon SB-27 flashgun can control its length of flash over the range from zero to a maximum of around 1/1000 second to make this feedback operation possible.]

'If it were necessary to try to characterize in a few words the difference between living organisms and inorganic systems, such a characterisation would not involve the presence of DNA, or any other purely structural attributes; but rather that organisms constitute the class of systems which can behave in an anticipatory fashion. That is to say, organisms comprise those systems which can make predictive models (of themselves, and of their environments) and use these models to direct their present actions.

'At the most fundamental level, anticipatory systems appear to violate those principles of causality which have dominated science for thousands of years. It is for this reason that the study of anticipatory systems per se has been excluded routinely from science, and that therefore we have had to content ourselves with simulations of their behaviour, constructed in purely reactive terms.'

6C Chaos

Smale and Williams (1976) showed that non-linear dynamic systems of order 3 or more may exhibit chaotic behaviour, first identified by Li and Yorke (1975). Chaotic behaviour is characterised by:

- (i) Any individual solution has a completely well defined deterministic trajectory.

- (ii) Very small perturbations, for instance to the initial conditions, can give rise to very large differences between later trajectories.
- (iii) Solutions of equations exhibiting chaotic behaviour may be difficult or impossible to distinguish from solutions generated by a purely stochastic process.

The difference equation

$$x(k+1) = rx(k)(1-x(k)) = f(x(k)) \text{ (say)} \quad (6.1)$$

can also exhibit chaotic behaviour as the parameter r is varied. (This is because the delay term implicit in a difference equation represents infinite dimensionality, as judged, for instance, by the order of s plane poles.)

There are two equilibrium points

$$\text{at } x = 0 \quad \text{and} \quad x = 1 - \frac{1}{r}$$

Behaviour of eqn. 6.1:

Equation 6.1, which arises in population dynamics, will be studied for the restricted set of values $0 < x < 1$. The behaviour of eqn. 6.1 may be understood graphically, using repeatedly a curve relating $x(k+1)$ to $x(k)$ as in Figure 6.7.

For use, $x(k+1)$ is derived from $x(k)$, then

$x(k+2)$ is derived from $x(k+1)$, etc.

The process can be simplified using a 45° line to transfer each ordinate value back to the abscissa to start the next iteration as shown (Figure 6.8). (Local) stability depends on the slope off near to the equilibrium point. This slope f' must satisfy

$|f'| < 1$ for stability

$$\frac{df}{dx} = r(1-2x)$$

and at the non-trivial equilibrium point $1 - 1/r$

$$\frac{df}{dx} = r \left(1 - \left(2 - \frac{2}{r} \right) \right) = 2 - r$$

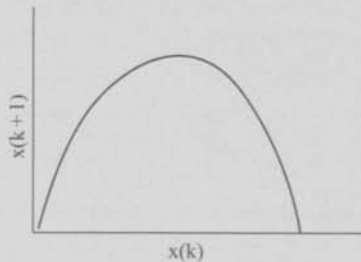

Figure 6.7 The curve relating $x(k+1)$ or $x(k)$ (relevant to eqn. 6.1)

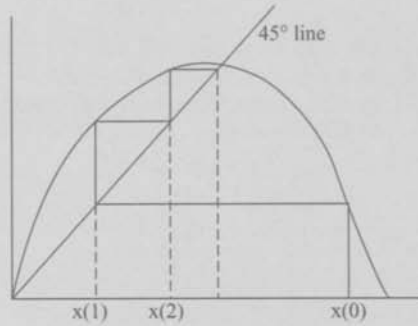

Figure 6.8 Graphical illustration of the iterations in the solution of eqn. 6.1

Thus the non-trivial equilibrium point is (locally) stable if

$$1 < r < 3$$

For $r > 3$, the solution is initially one that, in the steady state, oscillates between two fixed points. When r is increased further the system oscillates between 4, 8, 16, etc. fixed points. These stable oscillations with periods 2^n , $n \rightarrow \infty$, continue only up to a critical value r_c or r . For eqn. 6.1, $r_c = 3.57$. For $r > r_c$, very long cycles appear and different types of periodic behaviour are passed through. Between this type of behaviour occurs another type of behaviour where different initial points produce different totally non-periodic behaviour. It is this non-periodic behaviour that is called chaotic behaviour.

Segel (1980), Chapter 4, states that, for any particular value of parameter r , the set of initial conditions that gives rise to chaotic behaviour has measure zero. According to this, chaotic behaviour is atypical and should not therefore be considered as the obvious source of erratic behaviour in observed data. The most interesting aspect of all the foregoing is probably that very simple equations can give rise to highly complex solutions.

6D Mathematical modelling – some philosophical comments

It can be rewarding to glance sometimes beneath the mechanistic surface activity of mathematical modelling to query the hidden foundations. Here we content ourselves with the following brief discussions:

(1) On causality and time-ordering

Causality causes an awkward asymmetry in mathematics. Time hardly appears in pure mathematics and, where it does, anti-causality would be just as valid, feasible and usable.

Difficulties are most likely to be encountered when synthesising an optimal controller or an algorithm for reconstructing a continuous time signal from given discrete samples. As an illustration, let $y(t)$ be a continuous signal defined for all real values of t and let $y^*(kT)$ be the properly sampled version of the same signal. If now, given some specific t , it is required to recover $y(t)$ from the sequence of samples, the recovery algorithm will be found to have the form

$$y(t) = f \sum_{k=-\infty}^{\infty} y^*(kT)$$

for which, when used as a real time algorithm, only current and past values of $y^*(kT)$ can be available.

It would be desirable, but is not always possible, to insert a priori conditions into derivations to ensure that the solutions will be causal and therefore implementable. In transfer function manipulation, causality is ensured by simply outlawing as anti-causal, any transfer function whose numerator has a higher order than the denominator.

(2) Time-ordering

Aulin (1989) 'But sometimes the time-ordering between cause and effect is left unspecified, and only implied. Examples of this kind of causal law are Ohm's law, Coulomb's law, Biot-Savart's law, and the laws (Boyle, Gay-Lussac, etc.) that characterise the thermodynamic equilibrium. Examples of time-specified causal laws are, of course, plenty. Among them are the law of the freely falling body and other laws of mechanics, as well as the laws of electrodynamics. Common to all laws of physics mentioned above is that they are 'phenomenological laws', i.e. more or less conceived of as direct inductive generalisations from experimental results (or, if they are not, they can still be considered as such generalisations).'

(3) On the surprising simplicity of the mathematics that suffices to model very complex physical systems

Dietrich (1994) 'This is the old question about the unreasonable effectiveness of mathematics in the natural sciences or as Davies put it 'why the universe is algorithmically compressible' (i.e. why the obviously complex structure of our world can be described in so many cases by means of relatively simple mathematical formulae). This is closely linked to why induction and therefore science at all, succeeds. It is difficult to avoid asking whether mathematics, as the outcome of human thinking, has its own specificity which, for whatever reason, fits to the specificity of what man would see or experience. As long as this question is not comprehensively answered, science may explain much but not its own success.'

See also Eugene Wigner (1960) on 'The Unreasonable Effectiveness of Mathematics in the Natural Sciences.'

It seems that the Creator had only a few simple mathematical equations with which to underpin the immensely complex phenomena that the Universe contains. There are hundreds of illustrative examples of which the best known is possibly the law of gravity that Newton postulated based around very sparse and not very accurate observations of

falling bodies and of the motion of the Moon's path through the sky. Newton's laws fitted the few available observations of the time to within about 4 per cent. As observations have become much more accurate and more numerous it has been found that Newton's gravitational law is accurate to better than one ten thousandth of one percent.

A somewhat different illustration but equally impressive is the case of Maxwell's equations (1862) describing the magnetic field. Largely for reasons of symmetry Maxwell enhanced the equations with an expression that predicted the existence of electromagnetic waves which were unknown at the time. When Maxwell published his findings that electromagnetic waves may exist and propagate through free space, there was no way to verify that finding. However, there was available an approximate value at that time for the velocity of light and this was so close to the value calculated by Maxwell for his electromagnetic phenomenon that he wrote; 'It is scarcely possible to avoid the inference that light consisted of transverse undulations of the same medium that is the cause of electrical and magnetic phenomena'. In 1887 Hertz experimentally verified the existence of the electromagnetic waves predicted by Maxwell. [See Coulson and Boyd (1979) for more details on this topic.]

(4) On determinism and predictability

Strong determinism: the predictability, with certainty, of single future events in the given dynamical system.

Probabilistic determinism: the predictability of the probability distributions of future events.

Weak determinism: the predictability of the possibility distributions of future events.

Indeterminism: the unpredictability of all future events in the dynamic system concerned.

Thus, the concept of causality cannot be identified simply with 'determinism', but allows three different degrees of determinism and, in addition to them, a case of complete indeterminism.

(5) On reversibility and irreversibility

What is the general quantitative measure of irreversibility?

Nature does not permit those processes for which she has less predilection than she has for the initial states. The measure of nature's predilection was defined by Clausius as Entropy.

Consider the differential equations

$$\frac{d^2y(t)}{dt^2} + y(t) = 0$$

$$\frac{d^2y(t)}{dt^2} + \frac{dy}{dt} + y(t) = 0$$

The first equation can be seen to represent a reversible process that will have a similar solution for both t and $-t$. The second equation is stable for positive time but unstable for negative-going time. The lesson from this simple example is generalisable so that differential equations with only even order terms can be expected to represent reversible processes.

(6) On modelling social and political phenomena

At a deep enough level, both the arts and the sciences are seeking for meaning. At that level, do the arts and the sciences begin to merge?

Quoting Truesdell (1984): 'Nothing is easier to apply to socio-political phantasmagoria than failed mathematics substantiated by experiments programmed to confirm it.' and

'Rarely if ever does a scientist today read Newton and Euler as professors of literature read Shakespeare and Hemingway, seeking to translate into today's pidgin for their students the eternal verities archaically expressed by those ancient masters, or gathering material to use in papers for reverential journals read only by scholiasts (sic) of literature, who themselves read only to gather material to help them write more papers of the same kind.'

6E A still relevant illustration of the difficulty of mathematical modelling: the long march towards developing a quantitative understanding of the humble water wheel, 1590–1841

In this example, excessive reliance on a scientific theory that didn't quite apply significantly hindered quantitative understanding of the key phenomena involved.

In Britain in the eleventh century there were, according to the Domesday book, 5624 water mills; by the eighteenth century the number had increased to as many as 20,000. Water wheels were of great economic importance in most of Europe over many centuries since they provided the bulk of the power for many basic installations (mining, metal forming, milling) and they were also used to pump water, with notable examples being their use on the Seine at Marly where 14 water wheels lifted water 502 feet to supply fountains, gardens and palaces, including Versailles.

By the eighteenth century, there was considerable overcrowding of water wheels on many European waterways and in many locations, no more wheels could be fitted in. Thus there was a strong incentive to design water wheels of maximum efficiency.

The Problem

Few mechanisms seem easier to understand 'by inspection' than a basic water wheel. There are two types – 'undershot' (when the wheel dips into a stream or mill race) and 'overshot' where a duct feeds the water over the top of the wheel which then turns by the force of gravity (Figure 6.9).

Although it is obvious in the extreme how water wheels work and although nothing is hidden from our view and all the laws of gravity, force, etc. are, and were, well known, the development of quantitative understanding contains salutary lessons.

What is the more efficient, the overshot or the undershot wheel?

A theorem of Torricelli of 1638 states that water spouting from an orifice at depth H in a tank and water in free-fall for a vertical height H both have identical velocities (Figure 6.10). [Evangelista Torricelli (1608–1647) was an Italian mathematician and physicist who worked closely with Galileo and who gave his name to the Torricellian vacuum at the top of a mercury in glass barometer.]

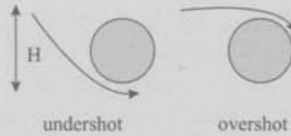

Figure 6.9 *Modelling a water wheel. There were 15,000 water wheels in Britain in the 1700s. Among those who studied it were Huygens, Maclaurin, Euler, Navier, Coriolis, Lagrange and D'Alembert. There were huge discrepancies between theory and observation. The typically British 'Method of coefficients' overcame this but made it difficult to know what, in the design, was significant. Accurate models only became available when systematic (expensive) experimentation was undertaken by the Franklin Institute, around 1830, by which time, steam was replacing water power*

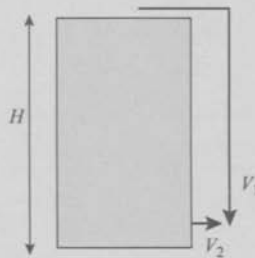

Figure 6.10 *Modelling a water wheel. The theory that misled: the velocities V_1 and V_2 are equal; $V_1 = V_2 = \sqrt{2gH}$ (Torricelli, 1638)*

This theorem is correct but it misled a series of scientists into wrongly assuming that impulse and weight were equally effective as motive powers and therefore that both types of water wheels (undershot, overshot) must necessarily have the same efficiency. Some of Europe's most distinguished scientists made armchair pronouncements purporting to be the defining relations for both types of wheels. Most of these pronouncements turned out to be well wide of the mark, as some sample quotations show (Table 6.1).

As Table 6.1 indicates, there were many rival theories producing quite different conclusions.

All real progress towards understanding was made on the basis of experimentation and in particular, in England, the land of pragmatists, an approach called 'the method of coefficients' had begun to be applied. The method was to multiply terms in theoretical equations by numerical coefficients to make theory agree with practice. Thus, two opposing views prevailed:

- that of the British camp typified by Milner (1778) who said:
'(Continental) writers who published water wheel analyses really had no intention of making any improvements in practice. They were simply illustrating the use of

Table 6.1 *Analyses of the vertical water wheel, c. 1700–c. 1800*

Investigator	Date	Maximum possible efficiency of wheel	
		Undershot	Overshot
Parent	1704	15	15
Euler	1754	15–30	100
Borda*	1767	50	100
Bossut	1770	15	
Waring	1792	25	
Evans	1795	58	67
Buchanan	1801	59	

* Borda's analysis proved eventually to be substantially correct but this was not verified and accepted until 70 or 80 years had passed.

algebra or the calculus. Too many arbitrary assumptions were made for them ever to correspond with reality.'

- *-and that of the continental theorists who complained that inexactness was inherent in coefficient equations, since resistance, friction, and all other losses were taken as a block and expressed by a constant coefficient. Every loss, they argued, depended on different circumstances; and could not be expressed by a single constant relationship. Since all losses were included in one figure, it was impossible to study the influence of each on the wheel's performance.*

So theoreticians continued to derive ever more complicated equations, pushing the mathematical analysis of the vertical water wheel to new limits, while practising engineers used the so-called method of coefficients in which experimentally derived coefficients were inserted into basic theoretical equations to bring them into close agreement with practice.

By 1835 the steam engine had arrived on the scene and had taken over more than 50% of industrial applications. As an anticlimax, by around 1850 extensive experiments had finally allowed the working-out of a fairly complete theory of water wheel operation and an understanding of the effects of various design features of performance.

In summary

- *Quantitative understanding of real processes is very difficult.*
- *Theory rarely (i.e. never) applies easily in an application context.*
- *Experimentation is difficult to plan or interpret without a theory.*

(Milner, I, 'Reflections on the communication of motion by impact or gravity', Royal Society of London, Philosophical Transactions 68, pp 344–379, 1778.)

6F A postscript on the effectiveness of thought experiments

(1) *A thought experiment about the water wheel*

One of the most impressive steps forward in the development of understanding of water wheel operation, see 6E above, was made by a thought experiment by de Parcieux (1754). He imagined a very slowly rotating frictionless water wheel gravity driven by dripping water. He was able to argue convincingly that no inevitable losses would occur in such a system and that the efficiency for an overshot wheel could therefore approach 100%, which turned out to be the case (de Parcieux, A. *Proceedings AS-M*, pp 603–614, Paris, 1754).

(2) *Another success for thought-experimentation; conjecturing about the International Date Line*

On Thursday, 10 July 1522, the Portuguese explorer Ferdinand Magellan completed one of the earliest circumnavigations of the world and on his arrival back in the Cape Verde Islands he and his crew were amazed that they had 'lost a day' since according to their carefully kept log, the day was Wednesday, 9 July.

Among many people who conjectured over this anomaly was Charles L. Dodgson (Lewis Carroll) who much later (1860) argued along these lines: 'Imagine that all the Earth were land and that a person could run right round the globe for 24 hours with the sun always overhead. That person would never see the sun rise or set. However, at the end of the trip the person would be at the same point they started from, but, 24 hours having elapsed, the day must have changed. So the question arises: at what point in the journey did the day change?

Dodgson's simple argument or 'thought experiment' makes very clear the need for some line where the date would change. (The International Date Line came into being only in 1884.)

6G Experimentation on plants to assist in model development – the tests that you need may not be in the textbook!

In order to allow simulation of different scenarios for a not-yet-built automation scheme it was necessary to know the load characteristics (inertia and friction as a function of angular velocity) of an existing composite gear train that was to be used in the system. The system, Figure 6.11, consists of a 30 kW motor driving a massive load through a gear train of about 1400:1 reduction.

This must be a common problem but the only reference found (Libby, 1960) was unhelpful. Acknowledged experts on mechanical drives who were asked to help sketched expected curves that later were shown to be qualitatively well wide of the mark.

The following simple test, inspired by an undergraduate laboratory experiment, provided all the information needed. The DC electric drive motor is switched on to the

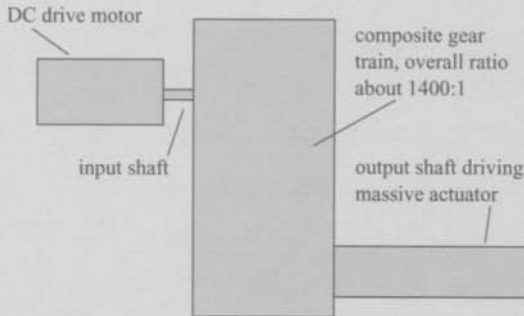

Figure 6.11 The motor and load whose overall inertia and torque as a function of angular velocity were determined experimentally

supply at voltage v and its steady-state current i and steady angular velocity ω_{\max} are recorded.

It is then argued that in the steady state,

(electrical power to the motor – losses in the motor)

= mechanical power delivered to the input shaft

or

$$vi - \text{motor losses} = \omega_{\max} T(\omega_{\max})$$

where $T(\omega)$ denotes the resisting torque of the load at angular velocity ω .

Leaving out motor losses for purposes of this explanation (since the principle is unaffected) allows calculation of $T(\omega_{\max})$ as

$$T(\omega_{\max}) = \frac{vi}{\omega_{\max}}$$

Next we switch off the motor and record the decay of ω against time, Figure 6.12.

The argument now is that at switch-off, the load torque $T(\omega_{\max})$ is the only agent that slows the shaft, whereas the effective inertia, call this J , of the whole load as seen at the input shaft is the agent that continues to drive the load in the absence of power being applied.

The relevant equation is

$$J \frac{d\omega}{dt} + \omega T(\omega_{\max}) = 0$$

The inertia J , assumed invariant for all ω , can be found from

$$J = \frac{-\omega_{\max} T(\omega_{\max})}{(d\omega/dt)_{\omega=\omega_{\max}}}$$

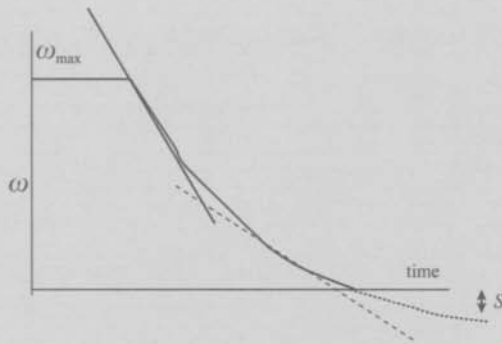

Figure 6.12 Illustrating how $d\omega/dt$ as a function of ω is estimated by tangents to the experimental curve. Notice also how the estimate S (not discussed in the text) is a useful measure of static friction in the drive

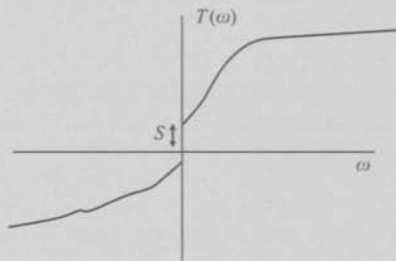

Figure 6.13 The final torque versus ω curve has this form. Here S denotes static friction (see Figure 6.12)

and by drawing the solid tangent shown in Figure 6.12, the inertia J can be derived. (In the case described here, a laborious day's work by the author, working on engineering drawings and referring approximate inertias all the way through the composite train, produced a confirmatory figure only 8% away from the experimental figure.)

Next a sequence of tangents (shown dotted in Figure 6.12) was drawn at frequent points along the ω decay curve and at each chosen ω . The load torque at each of the chosen ω was then calculated from

$$T(\omega) = \frac{-J(d\omega/dt)}{\omega_{\omega \text{ chosen}}}$$

allowing the curve of $T(\omega)$ to be plotted against ω (Figure 6.13). In use, it was stored as a look-up table interpolated by a subroutine at every step in an overall process dynamic simulation.

Chapter 7

Limits to performance

Most closed loop systems become unstable as gains are increased in attempts to achieve high performance. It is therefore correct to regard stability considerations as forming a rather general upper limit to control system performance. Also, as will be discussed in this chapter, achievable rates of change are always constrained in practice by equipment limitations.

7.1 Stability – initial discussion

A stable system is one that, when perturbed from an equilibrium state, will tend to return to that equilibrium state. Conversely, an unstable system is one that, when perturbed from equilibrium, will deviate further, moving off with ever increasing deviation (linear system) or possibly moving towards a different equilibrium state (non-linear system) (Figure 7.1).

All usable dynamical systems are necessarily stable – either they are inherently stable or they have been made stable by active design means. For example, a ship should ride stably with its deck horizontal and tend to return to that position after being perturbed by wind and waves (Figure 7.2).

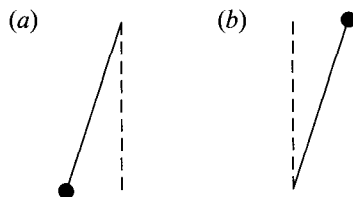

Figure 7.1 a Stable system
b Unstable system

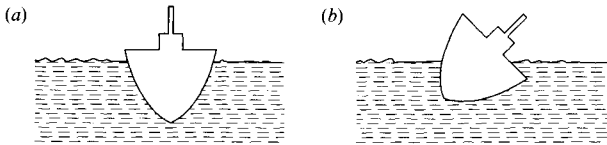

Figure 7.2 a Equilibrium position of ship
 b Ship when perturbed tends to equilibrium

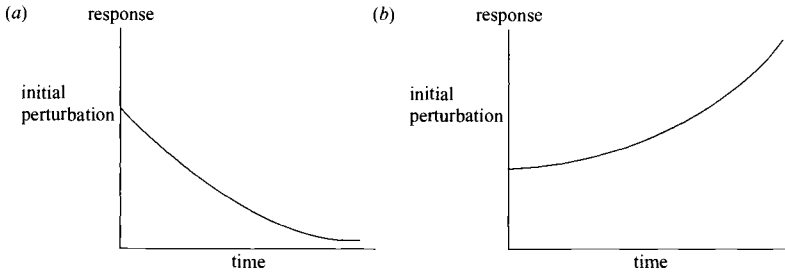

Figure 7.3 a Response of a stable system after perturbation
 b Response of an unstable system after perturbation

Stability occupies a key position in control theory for the reason that the upper limit of the performance of a feedback control system is often set by stability considerations, although most practical designs will be well away from the stability limit to avoid excessively oscillatory responses.

It is possible to check whether a system is stable or not by examining the behaviour with time, following an initial perturbation (Figure 7.3). To establish whether a system is stable or not, we do not need to know the solution of the system equations, but only to know whether after perturbation the solution decays or grows.

Notice that, for a linear system, the responses to initial perturbations of different magnitudes are identical except for a scaling factor. That is, let x_0 be the initial perturbation and $x(t)$ the resulting response; then the response to a perturbation kx_0 will be $kx(t)$. Therefore if a system is stable in response to one magnitude of perturbation, it will be stable in response to all other magnitudes.

7A Stability theory – a long term thread that binds

Stability analysis has a long and honourable history providing a thread that pre-dated control theory and then linked in with it.

Stability studies were applied to problems in planetary motion before control was even considered and most famously to the problem of the nature of Saturn's rings, Figure 7.4, for which Maxwell was awarded the Adams Prize. (Maxwell conjectured correctly that for the rings to be stable they must be particulate.) I took the 'Top' example in Figure 7.5

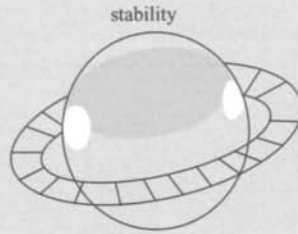
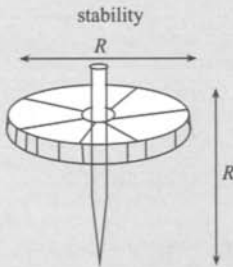

Figure 7.4 Saturn's rings. Maxwell's Adams Prize essay showed the rings to be particulate



The disc of a spinning top can be moved to three possible positions:

- (i) in the top 1/3 of the rod
- (ii) in the centre 1/3
- (iii) in the lower 1/3.

Show that the device will operate stably as a top only in positions (i) and (iii)

Figure 7.5 Maxwell's exam question to King's College London

from an examination paper that Maxwell set to an undergraduate class at King's College, London. It is not recorded how many, if any, answered the question with any degree of success but at the time no suitable stability criterion existed and the student would need to invent one. To make the question even more demanding, Maxwell added a rider to his question asking the student to state whether any invented stability criterion in the solution was necessary and sufficient!

The Hurwitz, Routh and similar criteria (see Section 7B) require knowledge of the differential equation of the system that is to be analysed.

Lyapunov's two powerful theorems (Section 13.2) have both algebraic and geometric interpretations that have allowed them to link with many aspects of non-linear control.

The Nyquist and Bode criteria which came next in the development require knowledge only of frequency responses in graphical form. These can be obtained experimentally and can form the basis for synthesis of controllers that will yield desired stability margins. This development allowed the earliest robust control systems to be systematically designed.

Table 7.1 highlights some of the famous names of stability theory.

Table 7.1 Some milestones in stability theory

A long term thread that binds

- *Maxwell: governors, Saturn's rings, spinning top*
- *Lyapunov: two stability theorems*
- *Hurwitz Routh: stability information from the coefficients of the (unsolved) differential equation*
- *Nyquist: graphical frequency response method*
- *Bode: developments of Nyquist approach*
- *Evans: root locus interpretation of Nyquist approach*
- *Jury: sampled data formulations*
- *Doyle: contributions to developing robust control methods*

7.2 Stability for control systems – how it is quantified

Let Σ be a linear system that is in an initial condition x_0 at time t_0 ; then the state of the system for $t > t_0$ is given by an equation of the form

$$x(t) = A e^{\alpha t} + B e^{\beta t} + \dots \quad (7.1)$$

where the number of terms depends on the dynamic complexity of the system, where the A, B, \dots terms depend only on the initial condition x_0 , and where the exponents α, β, \dots depend on the parameters of the system.

In general, the exponents α, β, \dots are complex and it is clear that, if even one of the exponents has a positive real part, then part of the solution of $x(t)$ will increase without bound as t increases and the system is seen to be unstable (since $e^{\alpha t} \rightarrow \infty$ as $t \rightarrow \infty$ if the real part of α is positive).

Stability therefore is governed only by the real parts of the exponents α, β, \dots . If our main concern is with stability, we therefore look in detail at these exponents. Let the dynamic systems have the mathematical model $H(s) = P(s)/Q(s)$. Then the exponents are the solution of the equation $Q(s) = 0$ (the auxiliary equation). These exponents are also called the poles of $H(s)$. Solutions of the equation $P(s) = 0$ are called the zeros of $H(s)$. It is useful to plot the poles and zeros of a system in the complex plane. Poles (marked X) and zeros (marked 0) appear always on the real axis or in complex conjugate pairs, arranged symmetrically above and below the real axis.

Recalling that if any exponent (pole) has a positive real part then the system is unstable, we can see that if any pole is in the right half of the pole-zero diagram then the system Σ is unstable and this is a major stability test for a system describable by a transfer function $G(s)$.

Table 7.2 Stability aspects of system models

System model	Stability governed by
Differential equation	Roots of auxiliary equation
Transfer function	Poles of transfer function
System matrix	Eigenvalues

Therefore the solution yielded by a system after perturbation is governed by the roots of its auxiliary equation if the system model is a transfer function, and by the roots of the characteristic equation (i.e. by the eigenvalues) if the model is a matrix. The situation is summarised in Table 7.2.

Control theory uses stability tests straightforwardly based on the information in Table 7.1 to yield qualitative stability information ('the system is stable' or 'the system is unstable') from differential equations, difference equations, transfer functions or system matrices.

The three forms of tests in Table 7.2 are all virtually the same test with relabelled variables. They all suffer from the same disadvantage – each test requires the solution of an equation of the form

$$s^n + a_{n-1}s^{n-1} + \dots + a_1s + a_0 = 0 \quad (7.2)$$

In detail this means finding every complex number α that satisfies

$$\alpha^n + a_{n-1}\alpha^{n-1} + \dots + a_1\alpha + a_0 = 0 \quad (7.3)$$

to yield the set of complex numbers $\{\alpha_1, \dots, \alpha_n\}$ which are the roots required by the stability test that is to be administered.

If in eqn. 7.2, $n < 2$, the solution follows 'almost by inspection' if $2 < n < 4$, then we can use analytic methods (Tartaglia's method for $n = 3$, Ferrari's method for $n = 4$); while if $n > 4$ then, by the celebrated proof due to Abel, no analytic solution can exist (see Turnbull (1963) and for a detailed discussion, Burnside and Panton (1892)).

It is, of course, possible to solve any particular equation of any order computationally, provided that it has numerical coefficients throughout. However, in the inevitable iterations of a systems design project it is very useful to be able to work, at least partially, with as yet unassigned coefficients.

Thus, for $n > 4$, it would be extremely useful to be able to answer the question (applied to eqn. 7.2 and using only a knowledge of the coefficients $[a_i]$): in what region of the complex plane do the roots $[\alpha_i]$ lie?

7B The ingenious method of Hurwitz

One solution to the problem came about as follows. The engineer A.B. Stodola, working on the dynamics of water-driven turbine systems, had been able already in 1893 to solve the stability problems that arose from his highly approximated model of order 3 ($n = 3$ in our eqn. 7.2). Although he was not in a direct position to apply the tests outlined in our Table 7.2 (not yet invented), he was equivalently able to apply the known work of Maxwell (1868) on systems of that order.

However, when Stodola produced a more complete model, with fewer approximations, for his turbine systems, he encountered the same problems that are described here. In modern terms, he wanted to know the location of the roots α_i of eqn. 7.2 from a knowledge of the coefficients a_i . The mathematician, A. Hurwitz, working at the same institution (ETH Zurich) as Stodola produced the Hurwitz criterion to solve precisely this problem. Stodola was able immediately to apply the criterion to ensure the stability of the design for a new hydro-electric power station that was being built at Davos.

Almost simultaneously, and independently, the Cambridge mathematician E.J. Routh developed an equivalent test, now called the Routh array test, to achieve exactly the same result as the Hurwitz criterion. Many control engineering texts explain one or other of the tests and with loose terminology indeed refer to it as the Routh–Hurwitz criterion.

Notice carefully that the Hurwitz criterion and the Routh array test apply to differential equations and hence also to the transfer functions and A matrices corresponding to such differential equations. They cannot be used to determine the stability properties of difference equations, since for difference equations a different question has to be asked; i.e. are all the roots α_i inside the unit circle in the complex plane? Equivalent to the Hurwitz test for differential equations is the Jury test for difference equations. (See Kuo (2002) for details of the Jury test.) Unfortunately, Jury's test can be unwieldy and this writer finds the so-called w transformation method preferable. In this method, the difference equation is transformed into a differential equation that has the same stability properties. The differential equation, obtained by transformation, is then tested as usual by (say) the Hurwitz method.

7.3 Linear system stability tests

Table 7.3 summarises the stability tests that we have available for linear systems.

Frequency response methods are widely used to synthesise closed loop systems having predetermined stability characteristics (refer back to Chapter 4).

7.4 Stability margin

From what has already been said, it can be inferred that there is a boundary between stable and unstable systems. A usable system must not only be stable but it must be away from the boundary of instability by some sufficient safety margin.

Table 7.3 Linear system stability tests

System description	Recommended stability test
<i>Continuous time systems</i>	
Differential equations	Roots of auxiliary equation
Transfer functions	Poles
System matrices	Eigenvalues
	Apply Hurwitz or Routh criterion
<i>Discrete time systems</i>	
Difference equations	Roots of auxiliary equation
Transfer functions	Poles
System matrices	Eigenvalues
	Jury test <i>or</i> w transformation then Hurwitz test

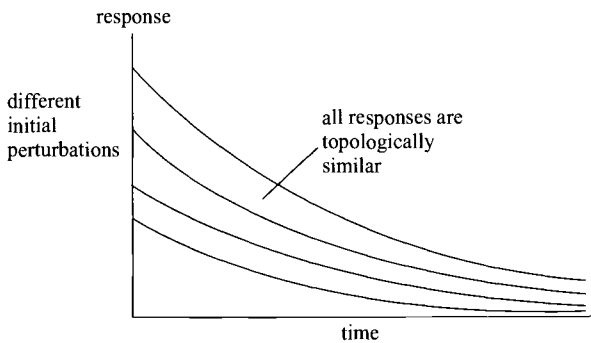

Figure 7.6 The family of responses to perturbations of different magnitudes for a linear system

7.5 Stability tests for non-linear systems

Why stability testing of non-linear systems is difficult

For a linear system, all solutions are ‘topologically similar’. For instance (Figure 7.6), for a linear system, all responses to initial perturbations of different magnitudes are similar (in a geometric sense). Thus if an initial perturbation $p(0)$ causes a response $x(t)$ then a scaled up perturbation $kp(0)$ will cause a scaled up response $kx(t)$.

However, the behaviour of a non-linear system can exhibit many surprising features. For instance, it is easy to synthesise a non-linear system whose response to two different initial perturbations $p_1(0)$, $p_2(0)$ is as shown in Figure 7.7.

It should be immediately obvious that even the definition of stability for a non-linear system will need to be carefully thought out.

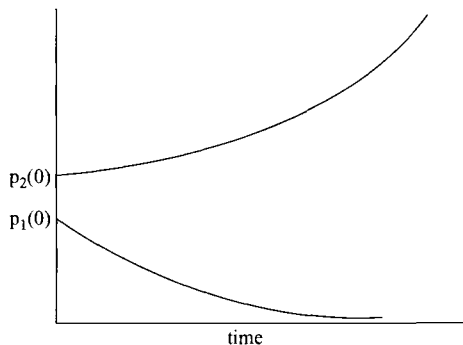

Figure 7.7 It is possible for a non-linear system to be stable for a perturbation $p_1(0)$ while being unstable for the perturbation $p_2(0)$

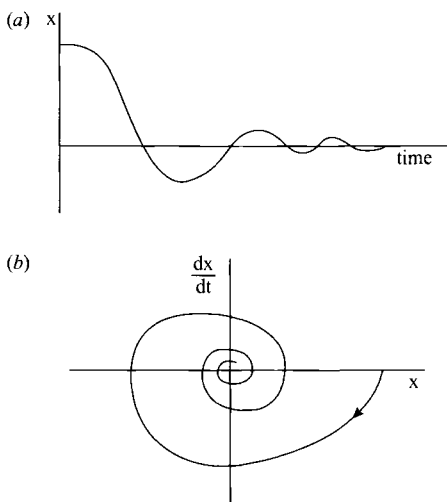

Figure 7.8 a A time response
 b The same response plotted in the phase plane

7.6 Local and global stability

In this treatment we consider non-linear differential equations and operate in the phase plane, thus effectively limiting illustrations, although not results, to second order systems. (We note in passing that non-linear differential equations do not yield transfer functions, poles, matrices, eigenvalues, frequency response descriptions, superimposable time responses or decomposable time solutions – i.e. auxiliary equations and complementary functions.)

The response to an initial perturbation as in Figure 7.8a can also be shown in the phase plane as Figure 7.8b, where time is a parameter along the trajectory.

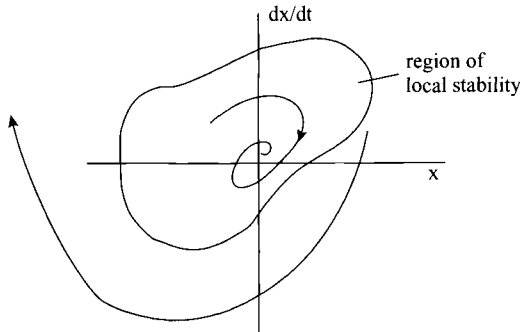

Figure 7.9 A region of local stability in the phase plane

A non-linear system where solutions starting at all points in the phase plane tend to the origin will be called globally stable – we can imagine that the origin is an attractor of solutions and that the domain of attraction is the whole of the phase plane.

In the case when the domain of attraction of the origin is a finite region in the phase plane, we call the system locally stable around the origin (Figure 7.9).

7.7 Lyapunov's second (direct) method for stability determination

Lyapunov's second method (often equivalently referred to as his direct method) has the following properties:

- (i) It can be understood most rapidly by reference to the energy contained in a system and the rate of change of that energy.
- (ii) Notwithstanding (i) it can be applied to abstract mathematical systems in which energy cannot be defined.
- (iii) It has a very valuable geometric interpretation.

We can bring point (i) to life by noting that a moving railway train whose brakes are applied will come to rest when its kinetic energy has all been dissipated in the brakes. If we wanted to calculate the stopping distance of such a train, it is possible to imagine using a method based on energy and its rate of change to do this. Moving to a second viewpoint, it is obvious that the ball-in-a-cup is at a point of minimum potential energy whereas the ball-on-a-dome is at a point of maximum potential energy (Figure 7.10). The relation between the energy minimum/maximum and the stability/instability of the balls is no accident.

The geometric interpretation of Lyapunov's second method is that 'a system is stable to the origin provided that every closed contour described by the so-called Lyapunov V function is always penetrated from outside to inside by solution trajectories of the differential equation and never in the reverse direction (Figure 7.11). Notice that some V functions will fail to confirm the stability of some stable systems as illustrated in Figure 7.12.



Figure 7.10 a Ball in a cup
b Ball on a dome

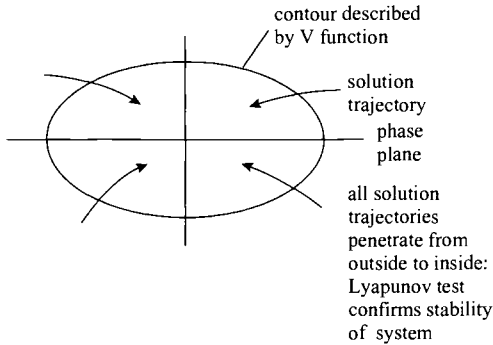

Figure 7.11 All solutions penetrate the V function contour from outside to inside

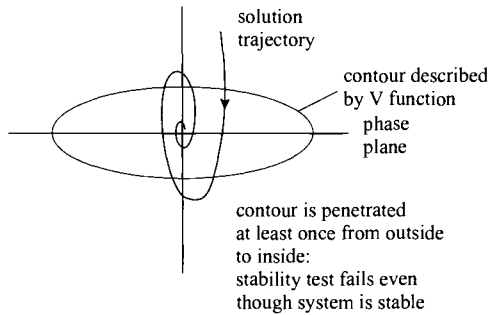

Figure 7.12 Contour is penetrated from inside to outside – stability test fails

Lyapunov’s test fails because at least one trajectory penetrates from inside to outside. We can see that the Lyapunov test is a sufficient condition for stability – it is not necessary.

7C Geometric interpretation of Lyapunov’s second method

Consider a solution trajectory $x(t)$ crossing a contour of constant V on its way towards the origin of the phase plane (Figure 7.13). Let the tangent to $x(t)$ be $\dot{x}(t)$ and let grad V and $-\text{grad } V$ be drawn in as shown (Figure 7.14).

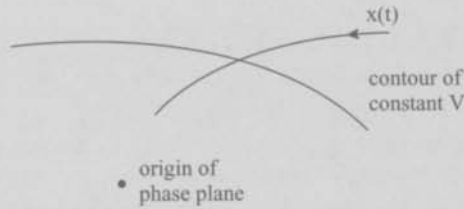

Figure 7.13 A trajectory crosses a contour of the V function

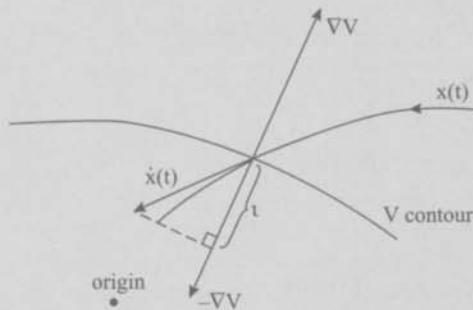

Figure 7.14 Figure 7.13 enhanced by gradient vector and tangent

Define

$$l = \left\langle \frac{\nabla V}{\|\nabla V\|}, \dot{x} \right\rangle \quad (,) \text{ indicates inner product}$$

i.e. l is the projection of \dot{x} onto the gradient vector ∇V . Note from Figure 7.14 that l is a vector, orthogonal to the V contour and that if l is negative, pointing towards the origin for every solution $x(t)$ and for every V contour, then the system is stable to the origin within the outermost of the V contours investigated.

Assume that V is positive definite and that lines of constant V form an increasing basin with the origin at its lowest point. Then the usual test that dV/dt must be negative definite for stability to the origin can be seen to be the same as asking that the vector l in Figure 7.14 should point inwards. This is so since

$$\frac{dV}{dt} = \frac{dV}{dx} \frac{dx}{dt} = \langle \nabla V, \dot{x} \rangle$$

which is the same (except for a scaling factor) as the expression for l in the figure.

7.8 What sets the limits on the control performance?

Let $G(s)$ be a model for any process whatever, connected into a control loop with a controller $D(s)$ whose transfer function is under our control. Let the overall model of the loop be represented by $H(s)$ (see Figure 7.15).

We ask: For a given $G(s)$ can we, by choice of $D(s)$, synthesise any $H(s)$ whatever? The following discussion is a continuation of an earlier discussion in Section 3.1.

From eqns. 3.4 and 3.3 (repeated here for convenience) we know that the overall transfer function $H(s)$ of the loop is (3.4)

$$H(s) = \frac{G(s)D(s)}{1 + G(s)D(s)}$$

and that the controller $D(s)$ can be chosen using (3.3)

$$D(s) = \frac{H(s)}{G(s)(1 - H(s))}$$

As an illustration of an ambitious design, let

$$G(s) = \frac{1}{1 + 1000s}$$

i.e. $G(s)$ has a time constant of 1000 s. We ask: can the controlled system be forced to have a transfer function of

$$H(s) = \frac{1}{1 + s}$$

by the connection of a suitable controller, i.e. can the system, when under control, be forced to respond one thousand times faster, with a time constant of one second?

This is a generic question of great practical importance: what sets an upper limit on the performance that can be obtained by adding control to a particular process G ? The complete answer will not be found by application of control theory but let us continue the example and then discuss the result.

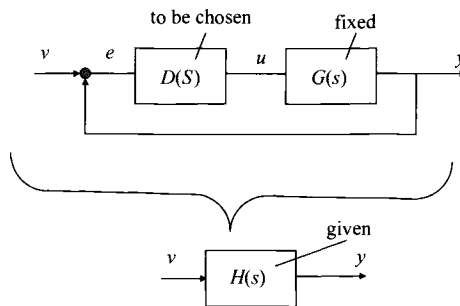

Figure 7.15 *Choosing $D(s)$ to achieve a given $H(s)$*

Putting the values into the equation for $D(s)$ yields

$$D(s) = \frac{H(s)}{G(s)(1-H(s))} = \frac{\frac{1}{1+s}}{\frac{1}{1+1000s} \frac{1}{1-\frac{1}{1+s}}}$$

$$= \frac{1+1000s}{s} = \frac{u(s)}{e(s)}$$

or

$$u(s) = \frac{e(s)}{s} + 1000e(s)$$

This controller can be realised by the hardware of Figure 7.16.

Physically there is no reason why the system of Figure 7.16 cannot be built. However, we note that, when the value v is changed suddenly to produce an error $(v - y)$ the output from the controller will instantaneously be $1000(v - y)$, which may saturate the actuator of the process $G(s)$ for any significant perturbation of v and, additionally, noise entering the loop may be expected to cause problems. Thus, we conclude that: if we are over-ambitious in our attempt to obtain high performance, we may meet limits caused by the finite power rating of signals that the process $G(s)$ can receive.

However, in applications we frequently do need to work around the loop from small sensor signals whose task is to carry information to the point where a large load of one sort or another may have to be moved, sometimes very rapidly. Such targets are not achievable by using large numerical gains in control loops but rather by power amplification.

To progress, consider particular applications. Imagine a hydro-electric power station where a huge controlled valve varies the flow of water to a set of turbines driving generators to vary the power generated and hence maintain the frequency of the whole supply. Such an application can be found at the Swedish hydro generating plant at Harspranget near the Arctic Circle. A delicate frequency sensor produces a signal of only a few mV and a closed loop system must drive the very large water valve in this application. This is achieved through an increasing sequence of amplifiers, motor generators and finally through a hydraulic actuator (Figure 7.17). This enormous amplification is seen to be stage-wise power amplification and not simply multiplication of gain. Most other applications will meet a maximum rate constraint in the form of the diameter of a pipe, the capacity of a heating burner, the power limitation of a motor or even a biological constraint such as that on the rate of organism growth.

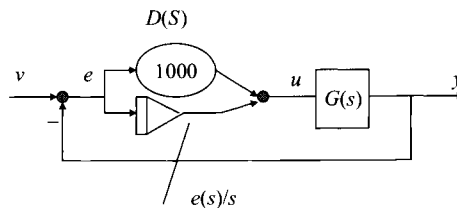

Figure 7.16 A hardware realisation to synthesise the required controller $D(s)$

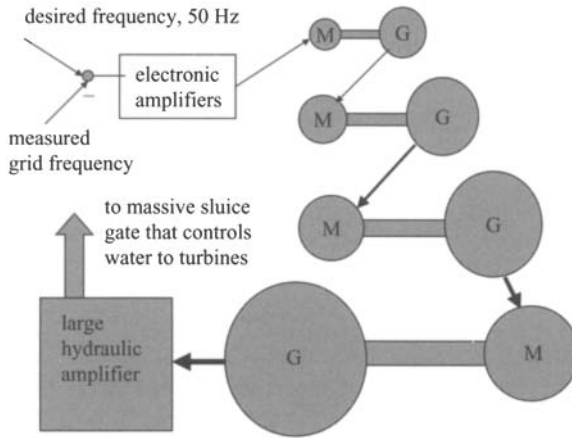

Figure 7.17 How power amplification is obtained in hydro frequency control

7.9 How robust against changes in the process is a moderately ambitious control loop?

Suppose that a control loop is designed to improve the rate of response of a process $G(s)$ by a factor of 10 times. How robust will the resulting loop be against changes in the process? We take a very simple example where

$$G(s) = \frac{1}{1+s}$$

and we shall design a controller $D(s)$ such that the resulting closed loop $H(s)$ has the transfer function

$$H(s) = \frac{1}{1+0.1s} = \frac{10}{10+s}$$

so that the closed loop system will respond ten times faster than the uncontrolled process. The necessary controller will have the model (see again Figure 7.15)

$$D(s) = \frac{H(s)}{G(s)(1-H(s))} = \frac{\frac{10}{10+s}}{\frac{1}{1+s} \left(1 - \frac{10}{10+s}\right)} = \frac{10(1+s)}{s}$$

This controller in closed loop with the given $G(s)$ will produce the required transfer function $H(s)$.

The purpose of this section is to check the effect of process changes on closed loop performance. We therefore postulate a significant but feasible change in the process time constant to yield the modified process model

$$G'(s) = \frac{1}{1+1.4s}$$

and calculate the resulting model, say $H'(s)$, of the closed loop as

$$H'(s) = \frac{\frac{1}{1+1.4s} \frac{10(1+s)}{s}}{1 + \frac{1}{1+1.4s} \frac{10(1+s)}{s}} = \frac{10(1+s)}{1.4s^2 + 11s + 10}$$

$H'(s)$ has two real poles at approximately $s = -2$ and $s = -5$ so it is not immediately obvious how the response of $H'(s)$ will differ from that of $H(s)$ (one pole at $s = -10$). To investigate this we shall calculate the step response of $H'(s)$ and compare it with that of $H(s)$.

(As a piece of reinforcement learning, we note that the step response of $H'(s)$ can be found by taking the inverse Laplace transform of $(H'(s)u(s))$, where $u(s) = 1/s$ is the transform of a unit step time function. Alternatively, we can argue that the response of $H'(s)$ to a unit step must be the integral of the impulse response of $H'(s)$. Since in the Laplace domain, the operation of integration is accomplished by multiplication by $1/s$, we again need to introduce this term before inverse transformation. In this short reminder, we have shown that the possibly puzzling fact that $1/s$ is simultaneously the transform of a unit step time function as well as the Laplace domain variable representing integration does not lead to any inconsistency.)

Therefore the step response of $H'(s)$ as a time function will be found by inverse Laplace transformation as

$$\mathcal{L}^{-1} \left(\frac{1}{s} \frac{10(1+s)}{1.4s^2 + 11s + 10} \right)$$

Figure 7.18a shows plots of the step responses of $H(s)$, $H'(s)$ with, for comparison, those of the processes $G(s)$, $G'(s)$.

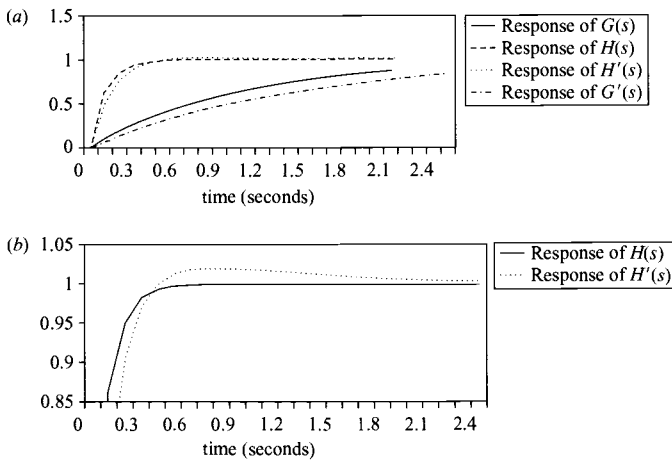

Figure 7.18 a The step responses of processes $G(s)$, $G'(s)$ alone and under closed loop control ($H(s)$, $H'(s)$)
 b Detail showing overshoot in response of $H'(s)$

The response of $H'(s)$ is remarkably close to that of $H(s)$, considering the large change in the process that has taken place. Closer examination (Figure 7.18*b*) shows however that the response of $H'(s)$ suffers from an overshoot that decays with a long time constant that is a legacy from the failure of the fixed controller $D(s)$ being unable to cancel the pole of the changed process $G'(s)$.

Overall, though, the result confirms the hoped-for robustness of a single feedback control in the face of process changes.

7.10 Limits and constraints on synthesis: summary of points

Given any process $G(s)$ and any required overall transfer function $H(s)$ it is always possible to calculate a controller $D(s)$ to ensure that the required $H(s)$ is obtained by substitution of $G(s)$ and $H(s)$ into the relevant equation.

Clearly in, say, aircraft design, $G(s)$ could be a model of a low performance aircraft, $H(s)$ could be the model of a high performance aircraft and $G(s)$ could be 'turned into' $H(s)$ merely by the addition of a suitable controller $D(s)$. However:

- (i) Not every $D(s)$ that can be written down is physically synthesisable.
- (ii) Even though $D(s)$ may be synthesisable, a very ambitious choice of $H(s)$ will necessarily lead to signals of large magnitude being generated during transients, necessitating the use of expensive powerful components.
- (iii) A very ambitious choice of $H(s)$ may lead to a control system whose performance is excessively sensitive to small changes in the process characteristics.

7.11 Systems that are difficult to control: unstable systems

Unsurprisingly, an inherently unstable system is usually difficult to control. Yet the combination of an inherently unstable aircraft, made usable by active stabilisation and control, is often attractive on grounds of overall efficiency and such a combination is often used in high performance military aircraft design.

There are also examples of deliberately unstable systems in nature. For instance, over many centuries, flying insects have evolved from stable passive long-tailed shapes, able to glide without exercise of brain power, to more efficient, but inherently unstable, short-tailed versions that include fast-acting measurement and closed-loop control and stabilisation.

Unstable systems have one or more poles in the right half complex plane and the most obvious control strategy would be to cancel the unstable poles by coincident right-half-plane controller zeros (Figures 7.19 and 7.20).

Questions arising are:

- (i) Can complete coincidence between poles and zeros be obtained and maintained?



Figure 7.19 An obvious strategy to cancel an unstable pole by a zero at the same location in the s plane

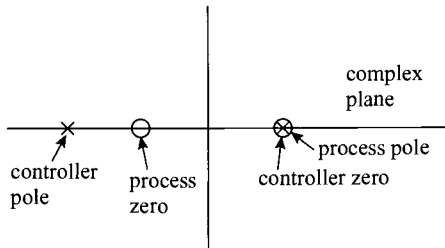

Figure 7.20 The cancellation strategy of Figure 7.19 illustrated in the complex plane

- (ii) If complete coincidence cannot be obtained, what are the consequences?
 (iii) If the method proposed is not workable, what other approaches might be used?

7D Cancellation of an unstable pole by a matching zero in the controller

Perfect cancellation of a pole at $s = 1$ would imply a term like $(s - 1)/(s - 1)$ in the overall transfer function. However, assume that there is a mismatch of ε in the calculation so that the term above is of the form

$$\frac{s - (1 + \varepsilon)}{s - 1}$$

This term has the step response

$$\frac{1}{s} \frac{s - (1 + \varepsilon)}{s - 1} = \frac{1}{s - 1} - \frac{1 + \varepsilon}{s(s - 1)}$$

equivalent to the time response

$$\exp(t) - \left(\frac{1 + \varepsilon}{-1} \right) (1 - \exp(t)) = (1 + \varepsilon) + \exp(t) - (1 + \varepsilon) \exp(t)$$

We see that perfect compensation implies that two exponential curves, going off to infinity in opposite directions, will precisely sum to zero (Figure 7.21).

Therefore, cancellation cannot work in practice since the instability is still present and we are relying on its effect being cancelled exactly by an equal and opposite effect.

(The differential equation would show the complete structure but the transfer function, having been subjected to cancellation, masks the true situation.)

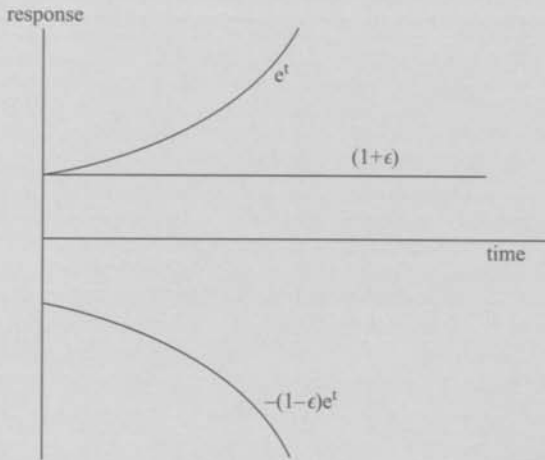

Figure 7.21 The components of the step response when there is a mismatch between pole and compensating zero

7E Shifting an unstable pole by feedback

As an alternative to attempted cancellation of an unstable pole, it may be possible to shift the pole by feedback (Figure 7.22). Taking the same unstable process as before, we examine the effect of the feedback shown. The overall transfer function is

$$\frac{s + 1}{s - 1 + cs + c} = \frac{s + 1}{(1 + c)s + c - 1}$$

and the system is genuinely stabilised provided that $c > 1$. The literature is fairly sparse on the control of unstable systems but see Willems (1970) and Takahashi et al. (1970).

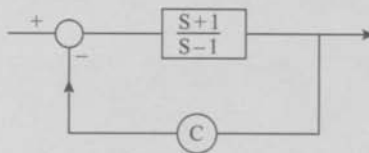

Figure 7.22 Feedback to shift an unstable pole

7.12 Systems that are difficult to control – non-minimum phase systems

Systems with this unwieldy name have the unpleasant characteristic that, when steered in one direction, they may initially respond in the opposite direction and only later move off in the required direction. For these interesting systems, we ask:

- (i) What features in the mathematical model of a system lead to the behaviour described above?
 - (ii) What is the motivation for the ‘non-minimum phase’ naming of the systems?
 - (iii) What sort of physical phenomena are responsible for creating the non-minimum phase behaviour?
- (i) Right half-plane zeros in the system model can be identified with the behaviour (or for a discrete-time model, Z plane zeros outside the unit circle).

Example The model

$$10y_k = 9y_{k-1} - u_{k-1} + 2u_{k-2}$$

has the pole-zero diagram shown in Figure 7.23a and the step response of Figure 7.23b.

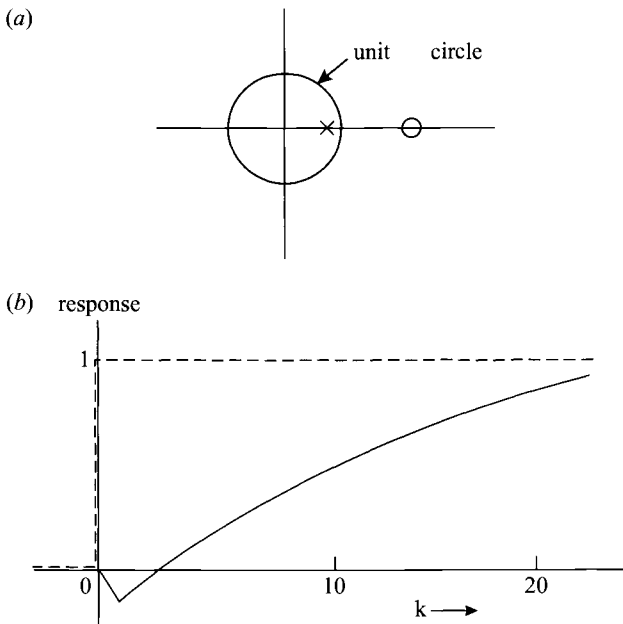

Figure 7.23 *a* Pole-zero diagram for a simple non-minimum phase system
b Step response of the system whose pole zero diagram in (a)

- (ii) Systems having no right half-plane singularities are called minimum phase systems. Systems having right half-plane singularities are called non-minimum phase systems. Therefore we say that a strictly stable system is minimum phase if it has no finite zeros in the right half-plane.

Caution: Clearly the numerators $(1 + s)$ and $(s + 1)$ are identical. However, the numerators $(1 - s)$ and $(s - 1)$ are very different in their phase characteristics. The first goes from 0 to -90° with increasing frequency whereas the second goes from $+180^\circ$ to $+90^\circ$ with increasing frequency.

- (iii) Physical phenomena that give rise to non-minimum phase behaviour. It is usually possible to correlate non-minimum phase indicators in mathematical models with physical phenomena. Examples are:
- Control of the level of a volume of boiling water. When cold water is added to raise the level of a mass of boiling water, the initial effect is the collapse of bubbles with consequent initial fall in water level.
 - Hydro-electricity generation. A requirement to increase the level of generated power from certain hydro-electric configurations results in an initial decrease in power during the time that the water in the pipeline feeding the turbines accelerates to the necessary increased velocity.
 - Sequences of interacting processes. Suppose that a sequence of interacting processes is operating in a steady state and that it is to be brought to a new steady state. Quite frequently the transient behaviour will move in the opposite direction to that intended. In a general sense this is because, at a call to increase activity, early processes in a chain immediately use additional shared resources whereas the benefits of their increased activity take time to work through the system.
 - Spatially distributed systems, being limiting cases of interconnected processes, often exhibit non-minimum phase characteristics.

General points: For a minimum phase system, the two components of the frequency response (i.e. gain and phase) are related by a known fixed bijective function – effectively meaning that either of the components contains all the frequency response information that exists. This fact is exploited in Bode’s theorems on stability (see Chapter 5).

7.13 Some interesting theoretical limitations on performance

It is well known that Shannon’s theorem sets a fundamental upper limit on the maximum error-free capacity of a communication channel. Less well known but important in the control field are a number of other fundamental design limitations, of which examples will now be given.

7.13.1 Sensitivity functions and their interrelation

(These interrelations play a major role in the loop shaping techniques that will be introduced in Chapter 16.)

7F Motivation for the name: non-minimum phase systems

Consider first the 'usual' system of transfer function

$$G_1(s) = \frac{(1 + sT_1)}{(1 + sT_2)(1 + sT_3)}$$

and compare it with the transfer function

$$G_2(s) = \frac{(1 - sT_1)}{(1 + sT_2)(1 + sT_3)}$$

It is clear that both transfer functions yield identical plots of magnitude as frequency varies.

However, the phase plots differ markedly, for, as the phase plot corresponding to the $(1 + sT_1)$ term in G_1 moves from zero to $+90^\circ$ so the phase plot for the $(1 - sT_2)$ term in G_2 moves from zero to -90° . Thus the high frequency asymptote for the phase angle is -90° for G_1 but -270° for G_2 .

Alternatively consider

$$G_3(s) = \frac{(s - 2)}{(s + 2)}$$

This has constant magnitude at all frequencies but the phase angle is $+180^\circ$ at low frequencies decreasing to 0° at high frequencies.

If two transfer functions are strictly stable with the same gain at each frequency then the one with all zeros in the left half plane will have least phase shift. Figure 7.24 illustrates the point.

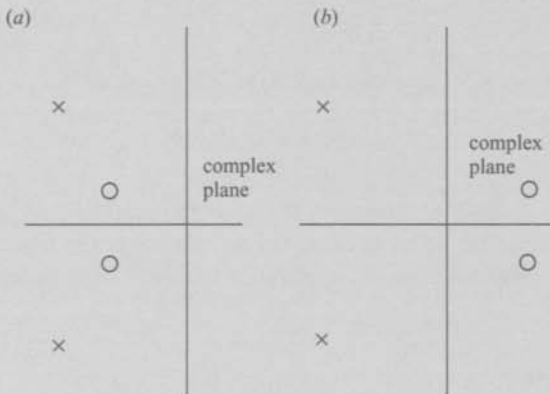

Figure 7.24 a The pole-zero diagram for a normal (minimum phase) system
 b The pole-zero diagram for a non-minimum phase system that has the same characteristics as the system in (a)

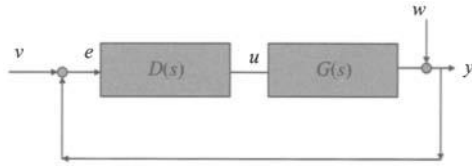

Figure 7.25 *Feedback configuration*

Consider a process $G(s)$ in a closed loop with a controller $D(s)$ (see Figure 7.25). We define two dimensionless sensitivity functions T and S as follows

$$S = \frac{1}{1 + GD} \quad T = \frac{GD}{1 + GD}$$

and note that at any frequency ω where $T(\omega) = 1$ we will have $y = v$, i.e. output = desired value.

Thus T links output y with desired value v , whereas the function S links disturbance output y with the disturbance input w .

Relations between T and S and their consequences.

By inspection,

$$S(s) + T(s) = 1 \quad \text{for all } s$$

This relation can be regarded as a constraint on design, preventing independent choices being made in regard to reference following and disturbance rejection performances.

7.13.2 *Integral constraints in the time domain*

Example 1 If the open loop combination $G(s), D(s)$ has the form

$$\frac{P(s)}{s^2 Q(s)} \tag{7.4}$$

i.e. has two poles (a double integrator) at the origin, assume the closed loop to be stable. Then, irrespective of what other (linear) elements the brackets in eqn. 7.4 contain, the error $e(t)$ following the application of a unit step applied at $t = 0$ must satisfy the relation

$$\int_0^{\infty} e(t) dt = 0$$

so that equal areas of positive and negative error must result as indicated in Figure 7.26.

Illustration of the effect discussed as Example 1

Assume that

$$GD = \frac{10s + 16}{s^2}$$

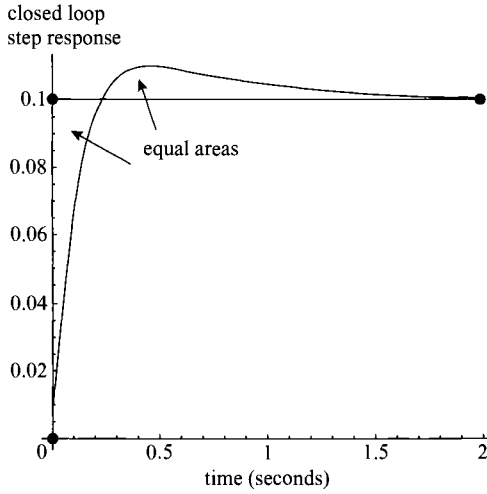

Figure 7.26 The closed loop step response of the open loop system $G(s)D(s) = (10s + 16)/s^2$

Note the equal areas marked, confirming that the double integrator leads to the error $e(t)$ satisfying the equation

$$\int_0^\infty e(t) dt = 0$$

following the application of a step at $t = 0$

so that

$$\frac{GD}{1 + GD} = \frac{10s + 16}{s^2 + 10s + 16}$$

with poles at $-2, -8$ and a step response in the time domain as shown in Figure 7.26.

If the open loop combination GD has right half plane poles or zeros then evaluation of the integral

$$\int_0^\infty e(t) dt$$

following the application of a step will, in each case, show that there are inevitable under- and overshoots in the closed loop responses, so that for instance, when a real open loop zero is present in the right half plane then the step response will inevitably begin with a negative-going response that is typical of so-called non-minimum phase systems (see Section 7F).

7.13.3 Design constraints caused by Bode's theorem

Bode's theorem states that

$$\int_0^\infty \ln |S(j\omega)| d\omega = 0$$

This shows that the average value of the sensitivity function S must be 1 on the imaginary axis so that if very small values of S are forced on the system for some range of frequencies, values greater than 1 will have to be accepted as pay-back over some other frequency range.

If one imagines that the loop can be shaped so that the undesirably high values of S occur at frequencies well outside the system bandwidth, this strategy turns out to be prevented by other constraints as Seron *et al.* (1997) shows (this is yet another manifestation of the well-known NFL [No Free Lunch] syndrome!).

This section is based on Seron *et al.* (1997), an interesting and comprehensive reference where more results can be found, and on Freudenberg and Looze (1985). Bode's theorem can be found in Bode (1945).

7G Mapping of complex functions – a few points that underlie classical control theory

Given $y = f(x)$, x and y real scalar-valued functions, there is only one path for x to follow, i.e. from $-\infty$ to ∞ and the resulting value of y is the usual 'graph' of y against x . No variation is possible.

However, for a complex (valued) function, $g = f(s)$, with complex argument s , the values taken by g depend on the path chosen for s in the complex plane. For instance (McCollum and Brown, 1965, p. 85), if s is allowed to vary as shown in Figure 7.27a then $G(s) = 10/(s - 2)$ varies as shown in Figure 7.27b.

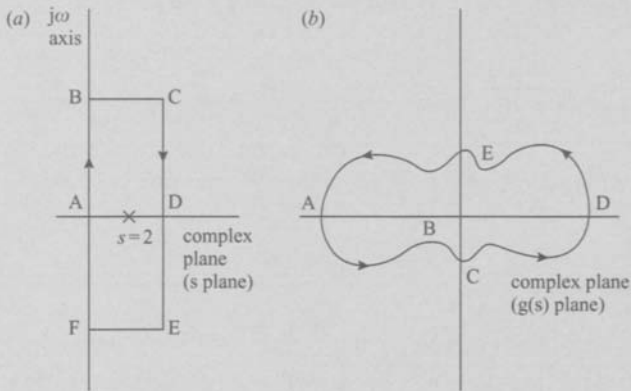

Figure 7.27 a A path in the complex plane
b The corresponding path for $G(s) = 10/(s - 2)$

Notice that the left contour encircles the pole at $s = 2$ in a clockwise direction, whereas the corresponding contour for g encircles the origin of the complex plane in an anti-clockwise direction. Further investigation would show that the direction of rotation of the g curve and its encirclement (or not) of the origin is directly related to the

presence or absence of poles and zeros within the region that is encircled by the s curve. Figure 7.28 gives further examples.

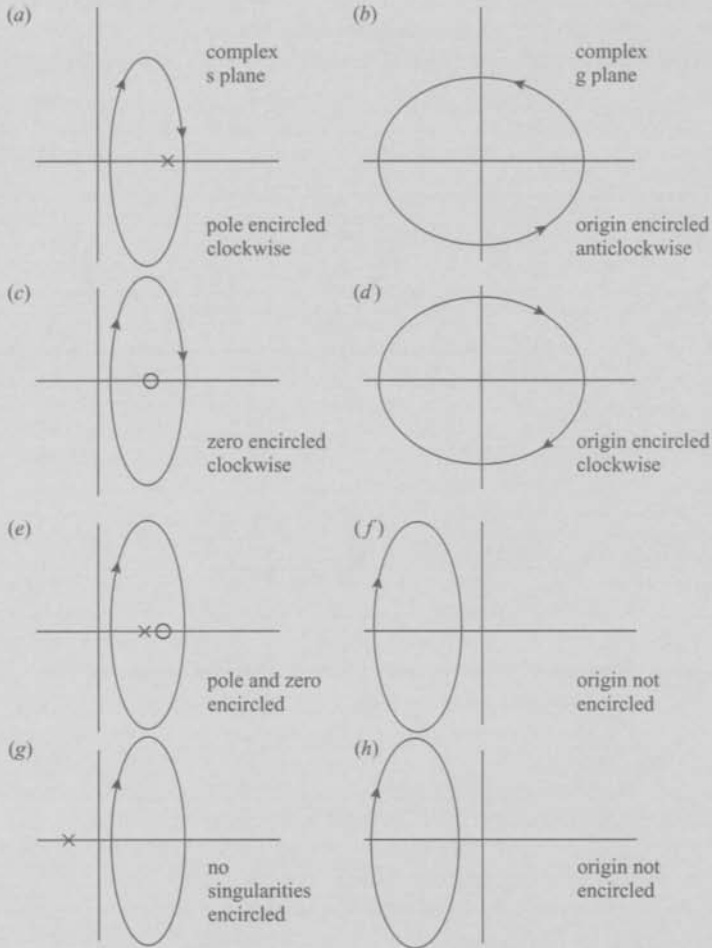

Figure 7.28 The left hand diagrams a, c, e, g show paths in the complex s plane. The right hand diagrams b, d, f, h show corresponding paths in the $G(s)$ plane

The foregoing material is part of the subject 'functions of a complex variable' which underpins all of the control work (stability, poles and zeros, etc.) that relies on transfer functions.

Returning to the mapping and encirclement discussion, if s is allowed to encircle the right half of the complex plane, then the behaviour of the transfer function $G(s)$, as s

varies, can indicate the presence of poles in that region. Since such poles imply system instability, this idea forms the basis for a major stability test – the Nyquist criterion.

Because we are interested principally in negative feedback systems, the function that we need to consider is not really $G(s)$ but rather $G(s)/[1 + G(s)]$. The form of the denominator shifts the emphasis from the origin to the point $-1 + j0$; this is the point whose encirclement or non-encirclement yields stability information for feedback systems.

7H Derivatives of a complex function $G(s)$

Not all complex functions are well behaved in the complex plane. Some are able to possess more than one value of derivative at the same point, according to the direction in which s is varied. Such behaviour is not possible when the function satisfies the Cauchy–Riemann conditions at almost all points in the plane. The function is then called an analytic function.

7I Singularities of a complex function $G(s)$

Singularities are the points at which G , or its derivatives, do not exist. The location and nature of the singularities determine the behaviour of the function in the entire plane.

There are three types of singularities: poles, essential singularities and branch points. If a positive integer n exists such that

$$\lim_{s \rightarrow s_1} (s - s_1)^n G(s) = k$$

where k is some finite non-zero value, then s_1 is a pole of $G(s)$ of order n .

An essential singularity, roughly, is a pole of infinite order. In control theory, essential singularities usually arise as models of dead time processes.

A branch point is associated with a multivalued function such as \sqrt{s} .

Behaviour of $G(s)$ near to a pole

$G(s)$ may be expanded in a Taylor series about a pole at s_1 as

$$(s - s_1)^n G(s) = A_{-n} + A_{-n+1}(s - s_1) + \dots + A_{-1}(s - s_1)^{n-1} \\ + B_0(s - s_1)^n + B_1(s - s_1)^{n+1} + \dots$$

Hence

$$G(s) = \frac{A_{-n}}{(s - s_1)^n} + \frac{A_{-(n-1)}}{(s - s_1)^{n-1}} + \dots + \frac{A_{-2}}{(s - s_1)^2} + \frac{A_{-1}}{(s - s_1)} \\ + B_0 + B_1(s - s_1) + \dots$$

which is called a Laurent series (study of the Laurent series and its connection with the behaviour of functions in the time domain can be pursued in Truxal (1955), pp. 4–29).

A_{-1} is called the residue of $G(s)$ at s . Near to the pole, the term in A_{-1} dominates the series.

Source material and suggestions for further reading to support the topics of this chapter will be found in Chapter 19.

Chapter 8

Some practical aspects of control design, justification and implementation

8.1 How efficient is it to control an unknown process by a controller that consists only of a high gain of value C that in the limit becomes a relay controller?

In view of the evident efficiency of feedback controllers in controlling unknown phenomena, is it not feasible to attempt control of all processes by some very simple standard strategy?

The simplest possible controller (Figure 8.1) involves just multiplication of the error by a scalar C ; the overall transfer function is $CG(s)/(1 + CG(s))$ and if C is very high, then the overall transfer function is approximately

$$\frac{CG(s)}{CG(s)} = 1$$

i.e. provided that $C \gg 1$ near-perfect control can be obtained.

Question: What happens as $C \rightarrow \infty$? Will this give better and better control?

Answer:

- (i) As C is increased, the system may become unstable and unusable.
- (ii) Assuming that the system remains stable as $C \rightarrow \infty$ (another question left for the moment is when does this arise?), then we have arrived at a switched (relay)

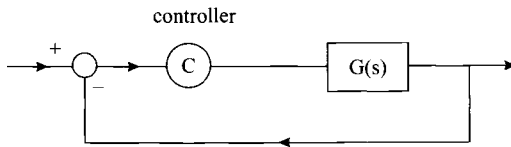

Figure 8.1 The simplest possible controller – a gain C

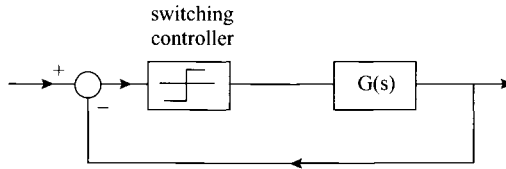

Figure 8.2 *The limiting condition: as $c \rightarrow \infty$ the controller becomes a relay*

control system (Figure 8.2). Such a system does indeed have a high performance and the low cost of a switching controller also makes such systems economically attractive. However, there are two disadvantages of (infinite gain) switching systems:

- (a) They are essentially non-linear (for instance, they respond (initially) in the same way to the input step $v = 1$ as to the input step $v = 10$).
- (b) The system never, under any circumstances, comes to rest: full power, in one direction or the other, is always being applied. For many applications, such behaviour is not acceptable.

Summary: A controller that consists only of a high gain C may give good control of a totally unknown process, though the upper bound for C may be set at a low value by stability considerations.

Where stability conditions allow, increasing the gain C will eventually result in a relay as the controller. Such a relay does indeed frequently give good control of an unknown process but brings problems (non-linearity, continuous oscillation) of its own.

Despite these disadvantages, relay control, also known as on–off control, has significant practical advantages that lead to its being widely applied across industry. The chief of these advantages is the very low cost of on–off actuators, compared with the continuously variable actuators needed for continuous control. On–off control manages to be surprisingly versatile. For instance it can:

- (i) achieve temperature control of a gas fired furnace by switching between high and low gas/air flow rates using only a pair of simple solenoid valves;
- (ii) operate conveyors or other large material handling devices at any chosen average flow rate by alternately switching between two different ratios of a gear-box;
- (iii) achieve continuously variable control of many devices, such as electric motors, by on–off modulation of an electrical power supply. For large applications the savings achieved by avoiding the need for continuously variable amplifiers/actuators often outweigh any disadvantage of the discontinuous operation.

Relay control systems can be analysed and designed using phase-plane and describing function methods – see Chapter 13 – and there is a specialist methodology for relay control systems that can be found in, for instance, Kochenburger (1950) and Flugge-Lotz (1968), two of the pioneers in the field. Tsien (1954) devotes an interesting chapter to the topic as do many of the older books on non-linear control.

8.2 An off-the-shelf approach to the control of an unknown process

Perhaps 80% of control problems encountered in industry can be solved routinely and do not require an extensive modelling and control design exercise. For such processes, a fixed structure commercially purchased three-term controller will probably prove adequate. Such devices can be discrete instruments fixed in racks or they may be invisible library algorithms within an overall monitoring and control package.

8.2.1 The three-term controller

Three-term controllers are the control practitioners' everyday workhorses. They are highly successful in practical situations but they are looked down upon by theoreticians and are not even mentioned in many undergraduate texts. The idea of a three-term controller, already introduced in Section 5.10, is:

- (i) To use a gain C that is to be set not too high, to avoid the problems of non-linearity and continuous oscillation that can arise from too high a C value.
- (ii) To add an integrator into the controller to ensure that, regardless of the value of C , a constant desired value v will result (after transients have died away) in a constant measured value y , with y being exactly equal to v .
- (iii) To add a differentiator into the controller to give independent control of the degree of damping.

8.2.2 Illustration of the value of an integral term in removing any constant error

Assume that the process to be controlled has the transfer function

$$G(s) = \frac{1}{s+1}$$

In closed loop in series with a simple controller of gain C , the steady state response to a unit step, as $t \rightarrow \infty$, is

$$\frac{C}{s+1+C} \quad \text{as } s \rightarrow 0 = \frac{C}{1+C}$$

Thus, for finite C , there is a constant error of $1/(1+C)$. When an integrator is added to the controller (in parallel with the gain C), the steady state response to a unit step is

$$\frac{sC+1}{s(s+1)+sC+1} \rightarrow 1 \quad \text{as } s \rightarrow 0$$

i.e. with the integrator present, the steady state error is zero.

8.2.3 *Illustration of the value of a derivative term to control the degree of damping*

The transfer function of the closed loop system of Figure 8.3a is

$$\frac{C}{(s+1)(s+3)+C}$$

If we now fix C at some numerical value, say $C = 65$, the closed loop poles will be located at

$$s = -2 \pm \sqrt{1-C} = -2 \pm j8$$

Very light damping is indicated by these pole positions.

If, now, referring to Figure 8.3b, a derivative term αs is included in the controller, then the closed loop transfer function becomes

$$\frac{C + \alpha s}{(s+1)(s+3)+C + \alpha s}$$

and, keeping the value of C set at $C = 65$, it is found that the closed loop poles are now located at

$$s = -\left(2 + \frac{\alpha}{2}\right) \pm \sqrt{\left(2 + \frac{\alpha}{2}\right)^2 - 3 - C}$$

And it can be seen that, by choice of α , the poles can be moved to positions giving any required degree of damping, although of course the effects of the introduced zero on overall performance will need to be considered.

8.2.4 *How can the three coefficients of a three-term controller be chosen quickly in practice?*

For most processes that need to be controlled, we cannot expect to have available an accurate or even an approximate model, since modelling is an expensive and time-consuming procedure. For routine situations, all we wish to know is how to set the

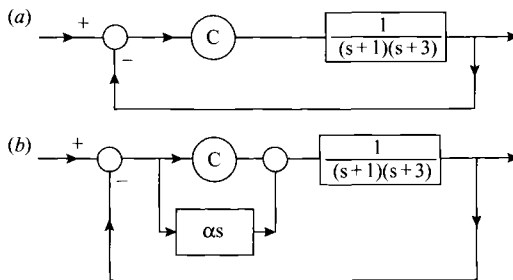

Figure 8.3 a A system under closed loop control with a simple controller of gain C
 b The system of (a), enhanced by a derivative term

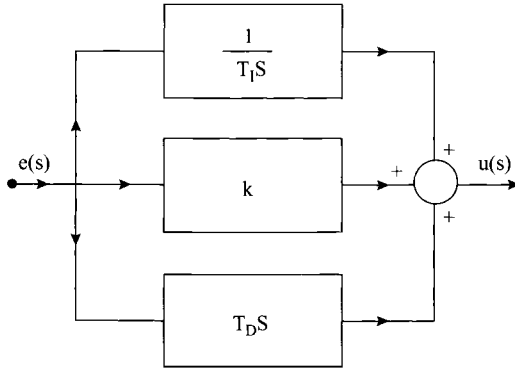

Figure 8.4 A three-term controller

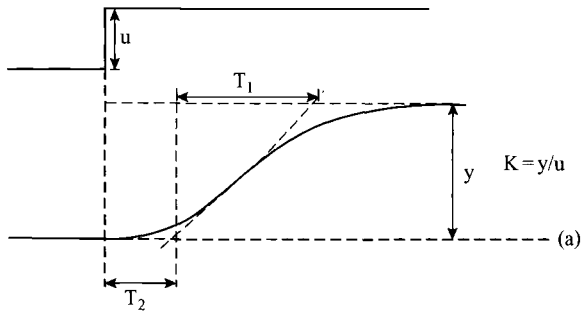

Figure 8.5 How the coefficients of eqn. 8.1 are determined

three coefficients: gain, derivative action, integral action, that are required by the three-term controller (Figure 8.4). There are three basic approaches.

8.2.4.1 To apply a step to the process that is to be controlled and use the response to calculate the coefficients

We shall outline that approach and give an illustrative example.

This approach is simple and reliable but it does require that the process is available and at one's disposal to have an open-loop step test performed. The procedure is as follows. The process, regardless of its actual (and in any case usually unknown) structure will be modelled by the approximation

$$G'(s) = \frac{K e^{-sT_2}}{(1 + sT_1)} \quad (8.1)$$

i.e. by a first order system in series with a finite time delay T_2 . The three coefficients K, T_1, T_2 are read off from the open-loop step response of the process using the graphical construction shown in Figure 8.5.

The three controller coefficients are then found from the Ziegler–Nichols (1942) equations:

$$\text{Controller gain } C = \frac{1.2 T_1}{K T_2}$$

$$\text{Integral time constant } T_I = 2T_2/C \tag{8.2}$$

$$\text{Derivative time constant } T_D = 0.5CT_2$$

Notice carefully that these controller coefficients are suggested to achieve control of the very large class of processes that can be approximated by eqn. 8.1 and further that the aimed-for step response of the resulting closed loop system is underdamped with the characteristic that the magnitude of each overshoot/undershoot shall be one quarter of the previous one. This type of response may not of course suit every application but the logic behind the choice is that such a response comes near to minimising the error criterion

$$J = \int_0^{\infty} |e(t)| dt$$

where $e(t)$ represents the error $y(t) - v(t)$ following the application of an input of a unit step to the input v at time $t = 0$.

Thus the Ziegler–Nichols rules are an attempt to design an optimal controller for the unknown process.

Illustrative example

We choose as the process that is to be controlled a plant with true model

$$G(s) = \frac{4}{(s+1)(s+2)(s+4)} \tag{8.3}$$

but to be realistic we don't (yet) allow ourselves access to knowledge of this model – only access to its response to a unit step (Figure 8.6*a*). From that figure and its amplification, Figure 8.6*b*, using the graphical construction given in Figure 8.5, we extract the approximate model

$$G'(s) = \frac{0.5e^{-0.4s}}{(1+2.12s)} \tag{8.4}$$

Figures 8.6*c* and *d* compare the actual response with the approximation. Then using eqns. 8.2, we find the three-term controller coefficients to be

$$\text{Gain } C = \frac{1.2T_1}{KT_2} = \frac{(1.2)(2.12)}{(0.5)(0.4)} = 12.72$$

$$\text{Integral time constant} = T_I = 2T_2/C = 0.0629 \tag{8.5}$$

$$\text{Derivative time constant} = T_D = 0.5CT_2 = 2.544$$

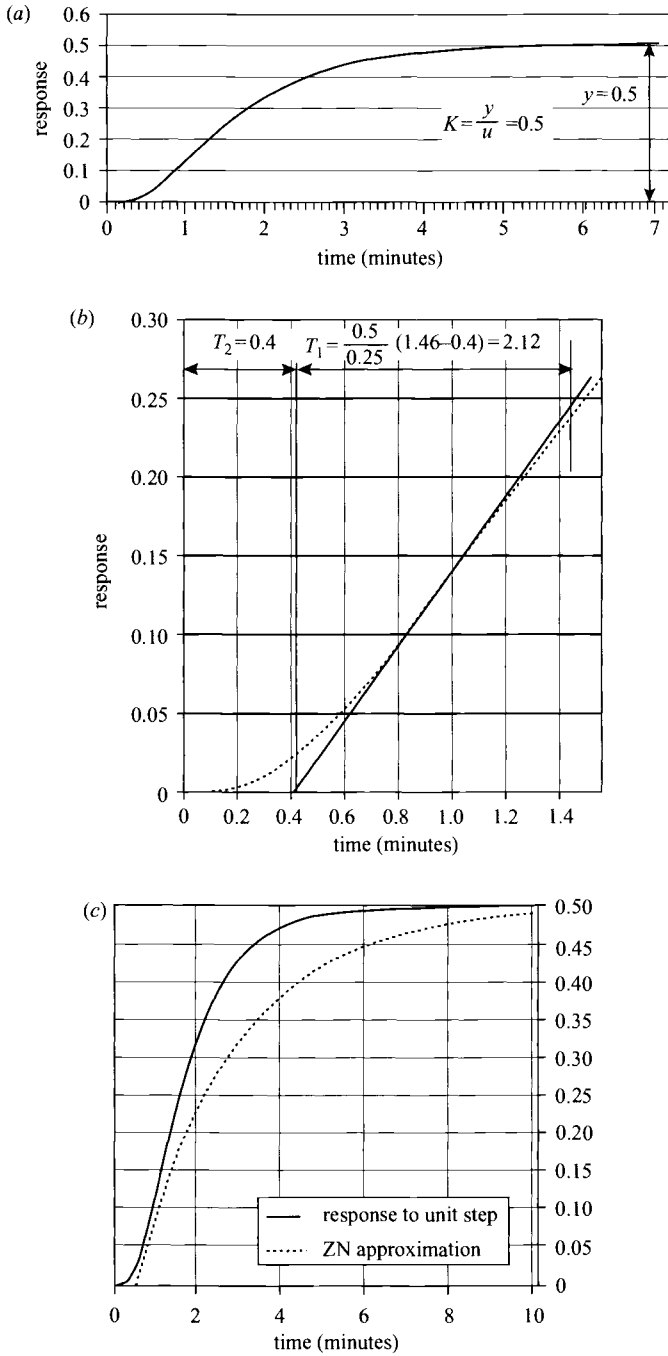

Figure 8.6 Continued

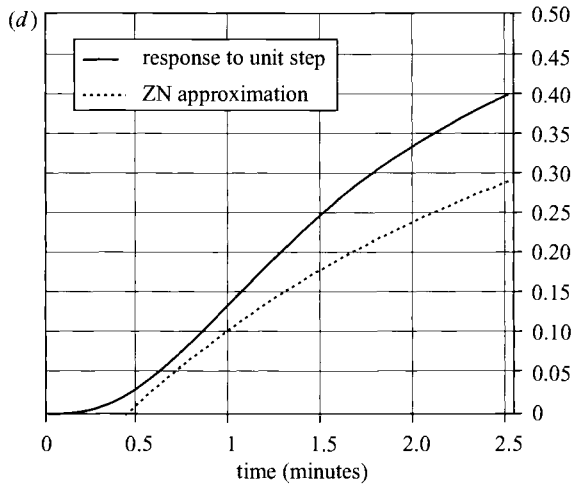

Figure 8.6 a Response of the process $G(s) = 4/[(s + 1)(s + 2)(s + 4)]$ to a unit step input
 b Response to unit step (graph expanded near origin)
 c Real process response and its approximation
 d Expanded detail from 8.6(c)

yielding the controller D as

$$D(s) = \frac{1}{s}(15.89 + 12.72s + 2.544s^2) \tag{8.6}$$

and the combination of controller and process in series as

$$G(s)D(s) = \frac{4(15.89 + 12.72s + 2.544s^2)}{s(s + 1)(s + 2)(s + 4)} \tag{8.7}$$

We have now allowed ourselves access to the true model $G(s)$, so that we can determine the step response of the closed loop, containing the three-term controller calculated via the approximation route.

The transfer function of the closed loop system $GD/(1 + GD)$ is

$$\frac{GD}{1 + GD} = \frac{4(15.89 + 12.72s + 2.544s^2)}{s((s + 1)(s + 2)(s + 4)) + 4(15.89 + 12.72s + 2.544s^2)} \tag{8.8}$$

To find an expression for the step response in the time domain of the closed loop system $GD/(1 + GD)$ shown above, we need to take the Inverse Laplace transform

of $\{(1/s)(GD/1 + GD)\}$ as shown below

$$f(t) = \mathcal{L}^{-1} \left(\frac{1}{s} \frac{GD}{1 + GD} \right) + \mathcal{L}^{-1} \left(\frac{1}{s} \frac{4(156.89 + 12.72s + 2.544s^2)}{s((s + 1)(s + 2)(s + 4) + 4(15.89 + 12.72s + 2.544s^2))} \right) \quad (8.9)$$

If we go to a package for the inversion in one sweep of the above transform, there is a danger of losing sight of the nature of the solution, so instead we factorise the expression and then take partial fractions to obtain

$$f(t) = \mathcal{L}^{-1} \left(\frac{0.995}{s} - \frac{0.04}{s + 2.164} + \frac{0.125}{s + 3.374} - \frac{1.079(s + 1.17)}{s^2 + 1.478s + 8.747} \right) \quad (8.10)$$

The last term has a denominator with complex roots expressible as

$$(s + 0.739 + j2.864)(s + 0.739s - j2.864)$$

which can also be expressed as

$$(s + 0.739)^2 + (2.864)^2$$

Still considering the last term in eqn. 8.10, we note that it has the form

$$\frac{1.079(s + a)}{(s + b)^2 + \omega^2}$$

which according to tables (e.g. McCollum and Brown, 1965) has the inverse transform

$$f(t) = \frac{1}{\omega} \sqrt{(a - b)^2 + \omega^2} e^{-bt} \sin(\omega t + \phi)$$

where

$$\phi = \tan^{-1} \left(\frac{\omega}{a - b} \right)$$

and in our case the time function corresponding to the complex term is therefore

$$1.079(0.35)(2.896) \exp(-0.739t) \sin(2.864t + 1.42) = 1.093 \exp(-0.739t) \sin(2.864t + 1.42)$$

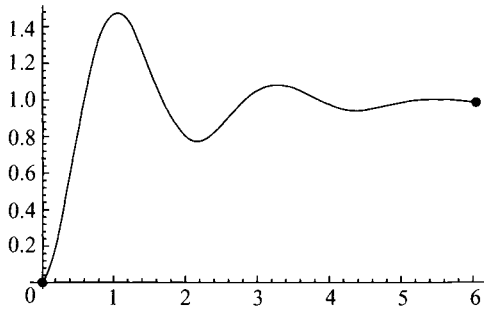

Figure 8.7 Step response of the closed loop system $G(s)D(s)/(1 + G(s)D(s))$

and the time function $f(t)$ corresponding with eqn. 8.10 can now be written as

$$f(t) = 0.995 - 0.04e^{-2.164t} + 0.125e^{-3.374t} + 1.093e^{-0.739t} \sin(2.864t + 1.42) \quad (8.11)$$

It is easy to see that the response will be dominated by the sinusoidal term in its envelope of decay and this is confirmed in the plot of Figure 8.7. It is clear that a good closed loop response meeting the criteria outlined above has been obtained with little effort using only information from a single step test of the process.

8A How to learn something from the first part of a step response

The initial part of a step response gives information about the order of the process. For a first order system, the steepest part of the response is at the origin but for higher order processes the response clings to the time axis before rising. To understand this, let A , B be first and second order processes, respectively, and let a , b , c be process parameters with obvious meanings. Then the respective step responses are:

$$f_A(t) = (1 - e^{-at}), \quad f_B(t) = \frac{1}{bc} \left(1 + \frac{1}{b-c} (ce^{-bt} - be^{-ct}) \right)$$

and the derivatives are:

$$f'_A(t) = ae^{-at} \text{ and } f'_A(0) = a$$

and this value a , the inverse of the process time constant, represents the steepest part of the response curve

$$f'_B(t) = \frac{1}{bc(b-c)} (bce^{-ct} - bce^{-bt}) = \frac{1}{(b-c)} (e^{-ct} - e^{-bt})$$

It is clear that the initial part of the step response of the second order process B has zero slope, since the second term in the expression for the derivative is zero at $t = 0$.

*The step response of a linear process and its frequency response both contain exactly the same information and both can be considered to be non-parametric models of the process (as opposed to transfer function models which have an **order** and contain **parameters** whose numerical values need to be chosen.)*

8.2.4.2 To fit the controller into a closed loop with the process to be controlled and go through a tuning procedure on-line

The method is if anything more difficult to conduct on a real plant (than approach 8.2.4.1) since it first requires that the controller with integral and derivative actions disabled be fitted into a closed loop with the process. The controller gain C must then be increased until the loop oscillates continuously at a constant amplitude. (This is not so easy as it sounds!) The controller gain C^* that causes continuous oscillation of the loop and the period T^* of the resulting oscillation are noted. From these two pieces of information, the three-term controller coefficients can again be determined from (additional) Ziegler–Nichols (1942) rules as follows:

$$\begin{aligned} \text{Controller gain } C &= 0.6C^* \\ \text{Integral time constant } T_I &= 0.5 T^* \\ \text{Derivative time constant } T_D &= 0.125T^* \end{aligned} \tag{8.12}$$

Here is an exercise for the reader to compare the two tuning methods. Starting with $G(s)$ as given in eqn. 8.3, devise and apply any theoretical method to determine C^* and T^* as described in this section. Calculate the controller coefficients using eqns. 8.12. Compare with the controller coefficients found above in Section 8.2.4.1. Comment constructively.

8.2.4.3 To fit a so-called self-tuning controller into closed loop with the process. After a learning period, the controller will hopefully have chosen its own coefficients

There are quite a number of self-tuning algorithms, many of them quite complex. Some approaches use an expert system that emulates a skilled human control engineer; other approaches emulate approach 8.2.4.2, exciting the loop and then interpreting the responses. Every practical self-tuning algorithm must necessarily have some sort of confidence test to pass before it can be allowed to implement its choice of coefficients onto the real process. There is an extensive literature.

8B New York to San Francisco telephony – an early illustration of the spectacular success of feedback in achieving high-fidelity amplifications of signals

In early long distance telephony, messages travelled along a land line with repeater stations (audio frequency amplifiers) at intervals to boost the signal strength. Early electronic amplifiers were highly sensitive to variations in thermionic valve (U.S.A. tube) characteristics and variations in supply voltage. This meant that the gains were not constant and that consistent high fidelity amplification was not possible. If, say, ten such amplifiers each reproducing a signal with 90% fidelity were connected in series (as repeater stations must be) then the fidelity of the overall line would be $100(0.9)^{10} = 35\%$. Because of the poor robustness of available repeater amplifiers it was decided that no more than six such repeaters could be tolerated along the whole 3000 mile (4800 km) line. The signal strength was kept high by the use of massive power cable capable of carrying 50 amps and weighing half a ton per mile (300 kg per km).

No doubt motivated by this problem, Harold Bode, Bell Telephone Laboratories, c. 1927, invented and implemented feedback amplifiers to produce highly insensitive (i.e. gain robust to parameter changes) amplifiers for transcontinental telephony.

These amplifiers using feedback were of such high fidelity that 600 could be used sequentially as repeater stations when a new New York to San Francisco light weight cable was laid in 1941.

Figures 8.8–8.10 illustrate this example.

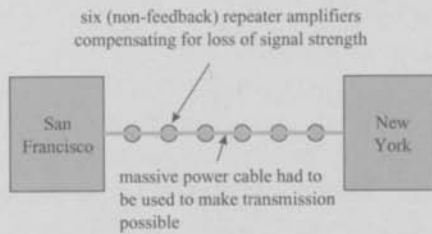

Figure 8.8 First trans-US telephone cable. No more than six amplifiers could be used because of the cumulative distortion effect

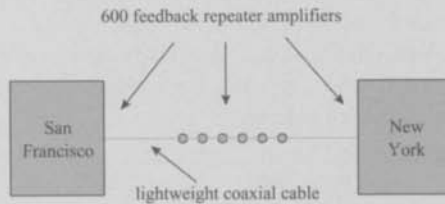

Figure 8.9 By 1941, the availability of Bode's feedback amplifier allowed 600 amplifiers to be connected sequentially and a low cost lightweight cable to be used for the connection

$$y = \frac{KG}{1 + KG} u \quad \text{nominal process}$$

$$y = \frac{K(G + \Delta G)}{1 + K(G + \Delta G)} u \quad \text{perturbed process}$$

Figure 8.10 If the amplifier gain K is sufficiently high, the feedback loop is insensitive to process perturbations ΔG or gain perturbations ΔK

8.3 Converting a user's requirements into a control specification

A user's requirement will usually be application-specific (keeping a ship on a desired course to a particular accuracy; dispensing a certain weight of soap powder; neutralising a liquid effluent before discharge to a river; maximising the yield of pharmaceutical product from a given batch of raw material, etc.).

An unrealistic (oversimplistic) conversion of the user's requirement into a control specification, against which the system will be built, will result in the building of an unsatisfactory system. This aspect (conversion of a user's requirements into a specification) is frequently a weakness in the control design chain.

Let us switch our thoughts temporarily to the amount of freedom that a designer has in designing a simple control loop. First, the control loop will need to be stable with a reasonable stability margin. This stability margin will need to be more or less the same, regardless of the application; hence, although the designer has to fix the stability margin, that margin will be virtually the same regardless of application and therefore this aspect cannot be regarded as a variable design parameter. The other variable that can be fixed by the control designer is the speed of response or the closely related parameter, system bandwidth. Both of these quantities are related in a well-defined way with pole locations and with system natural frequency.

Thus, in the design of a simple control loop, the designer will often be seeking to achieve a particular bandwidth or a particular speed of response by fixing pole locations, by fixing natural frequency or by fixing bandwidth in the system to be synthesised. Figure 8.11 illustrates the design route.

Two important questions arise:

Question 1: How can diverse users' requirements be converted into very simple speed of response or bandwidth specifications?

Answer 1: They can't, except in a small minority of cases that are mostly confined to the servomechanism field. In most other cases, the designer spends huge proportions of his time coping with application-dependent problems, using general engineering knowledge and *ad hoc* methods.

Question 2: What sets an upper limit on the speed of response (or bandwidth) that can be obtained in a particular application?

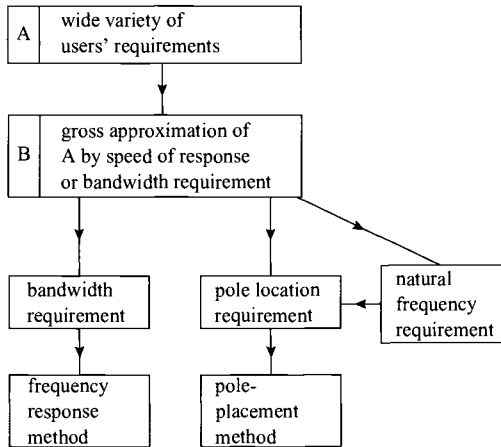

Figure 8.11 *Alternative design approaches*

Answer 2: Very interesting! In linear control theory, there are by definition no upper limits on anything. Thus, linear control theory can produce a system that will turn a supertanker onto a new course in microseconds or less, provided that the linearity is not violated.

Thus, the upper limits on performance are set by factors that do not appear at all in the design process. Clearly this is very unsatisfactory!

In practice, the designer must choose, for example, an electric motor to give the acceleration that he needs. As larger and larger motors are considered, so the acceleration will approach that given by an unloaded motor. If this acceleration does not meet the specification, another approach must be found. The point to note is that none of this procedure is part of the control design procedure but is injected by the designer in what is usually called engineering interaction with the design process!

8.4 Methodologies for deciding the scope and attributes of automatic control schemes for industrial application (methodologies for economic justification of investment in automation)

8.4.1 Methodologies and illustrations

Given a set of interlinked industrial processes that together constitute a plant producing some product from incoming raw materials, control theory and practice will tell what might be achieved at each of the processes. The list of all possible schemes that might be designed would be formidable indeed. The question we want to consider here is: given a particular industrial configuration, how can one describe the scope, configuration and functionality of appropriate control systems to be integrated into the manufacturing facility in something close to an optimal way.

Here we review some of the available methodologies but it has to be said that there is a distinct shortage of methodologies – in fact most of those described below were originated by the author. The lack of literature is a sign not of lack of importance of the approaches but rather a result of the methods being unglamorous and theoretically undemanding, making them unattractive to academics because of their unsuitability for publication.

The first suggestion is to define for a whole production sequence a broad sweep performance index of the form

$$J = \text{APP}(\text{Price at which one tonne of product sells} \\ - \text{Cost of manufacturing one tonne of product})$$

where APP is the annual production, tonnes, of prime product.

Our broad aim in choosing between alternative strategies will then be to maximise J but how do we calculate the cost of manufacturing one tonne of product? The solution is to develop a model of the form shown in Figure 8.12 for every process in the production sequence and eventually through the use of these interconnecting models we can link right back from product leaving the factory to raw materials entering the factory. The operation of the models is self-explanatory but it remains to mention that the models have to be parametrised by analysing masses of real industrial data. The examples given here as Figures 8.13–8.15 relate to the steel industry and show how the product, steel strip, links back to the basic raw materials of iron ore and coking coal. The figures given here are realistic but they have been modified for confidentiality reasons. The models allow the economic context of the process to be understood with the main areas for possible savings being visible to a large extent by inspection.

As indicated symbolically in Figure 8.16, how do we decide what automation projects to choose and what should be the resource allocation for each?

Figure 8.17 shows a ‘justification histogram’ produced by the author, with colleagues, from measurements on 2000 batches of steel strip. It shows that almost 10%

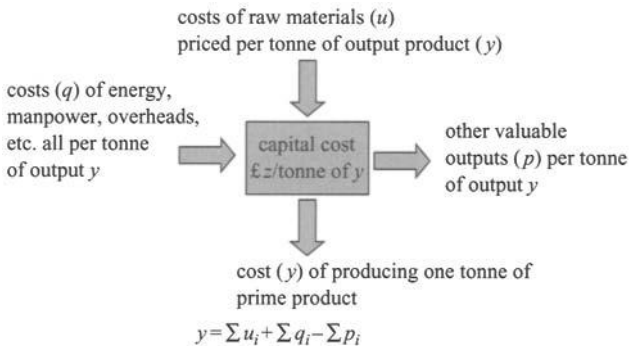

Figure 8.12 Calculation of the cost (y) of production for an entire plant or for a single process in most of my work z has been omitted

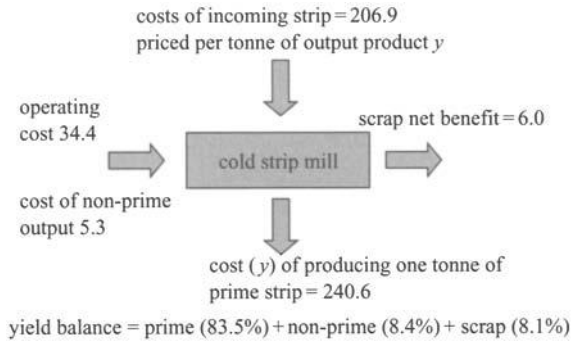

Figure 8.13 Sample cost calculation: cold strip mill (strip from strip production)

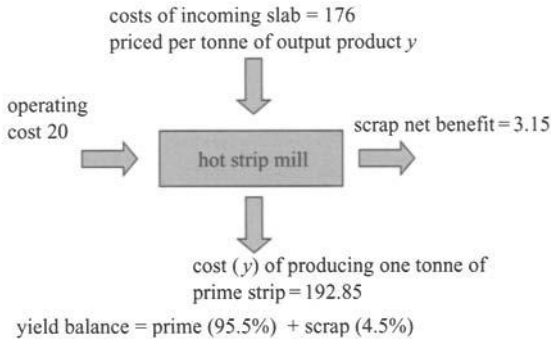

Figure 8.14 Sample cost calculation: hot strip mill (strip from slab production)

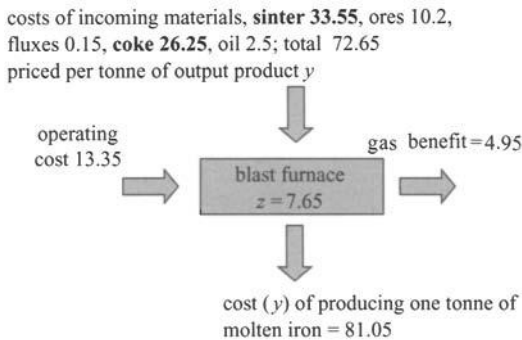

Figure 8.15 Sample cost calculation: iron-making (molten iron from sinter production)

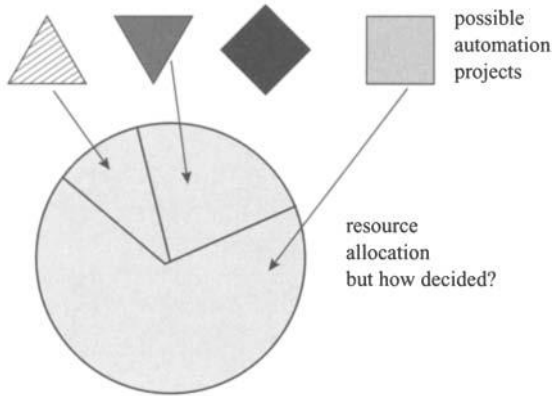

Figure 8.16 How do we choose automation projects and what should be the resource allocation for each?

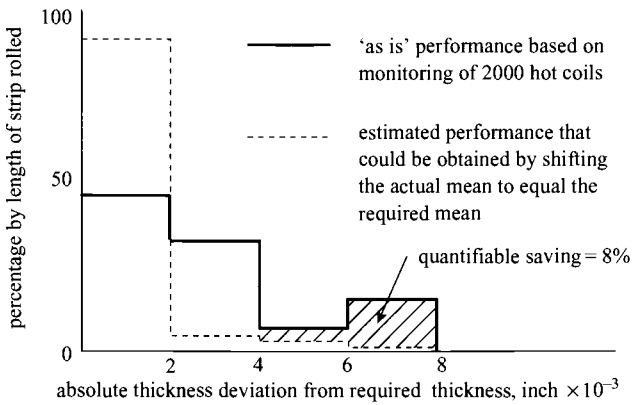

Figure 8.17 Justification histogram

of the lengths of strip produced were outside the allowed thickness tolerance and allows quantification to be made of the benefits of tighter control.

Figures 8.18 and 8.19 show what I call an ‘economic dynamic programming’ approach to choosing the best control configuration for a set of closely interlinked sequential processes. The idea is that at each stage of the process there are, in the example, three control design choices – let us say ‘minimum cost’, ‘medium cost’, ‘high cost state of the art’. This means that, in a six-stage process there are $3^6 = 729$ possible configurations.

The assumed aim of the control system in this simple example is to reduce product variance and the dynamic programming approach eliminates all non-optimal ways of achieving a particular variance so that, by coarse discretisation, we can obtain, as shown in Figure 8.19, four possible levels of performance and for each we offer

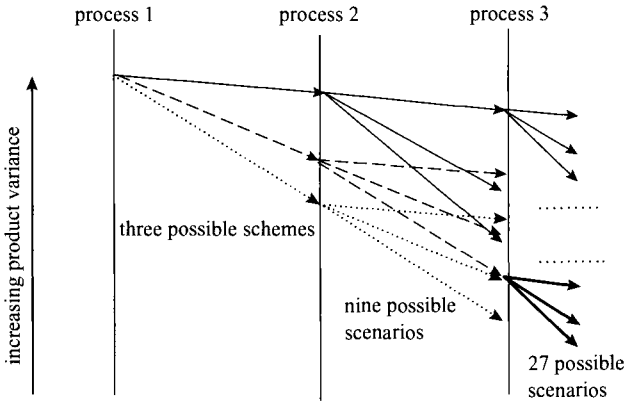

Figure 8.18 Investment strategy tool for n linked processes
 (I have used this tool with a dynamic programming approach to eliminate all definitely suboptimal strategies)

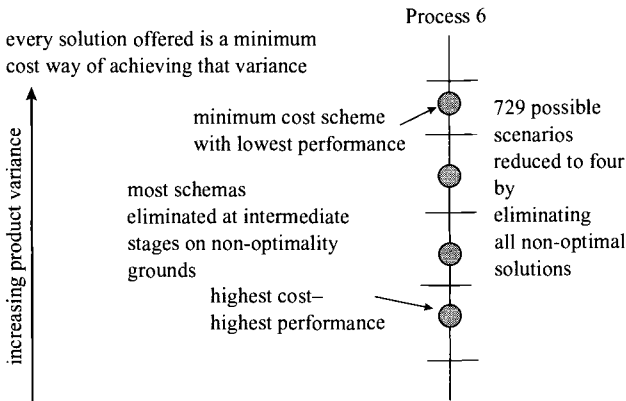

Figure 8.19 Investment strategy tool for six processes with three choices at each stage

the unique minimum cost way of achieving that performance. (For each of the three possible solutions we have an implementation cost and of course we need either a deterministic or stochastic simulation that can generate estimates of the intermediate performances.) The method allows the designer to allocate the task of reduction of variance optimally between several closely linked sequential process stages.

In calculating the rate of return for a possible automation scheme, there will usually be a lowest acceptable rate of return, dotted in Figure 8.20, and all schemes, to receive funding must normally generate a return at a slope greater than this. Note though that most automation schemes can be broken up into several component parts

(Figure 8.20) and that as shown in the figure unprofitable components may be hidden by the compiler of the diagram.

Figure 8.21 shows a typical time history for the increase in performance for the commissioning of a typical large and complex automation scheme. The characteristic performance fall before rising degrades the return on capital very significantly and may make a whole automation project uneconomic.

Finally, Figure 8.22 shows how, for many processes, there is another technico-economic consideration: how to decide on an optimal throughput rate that is a

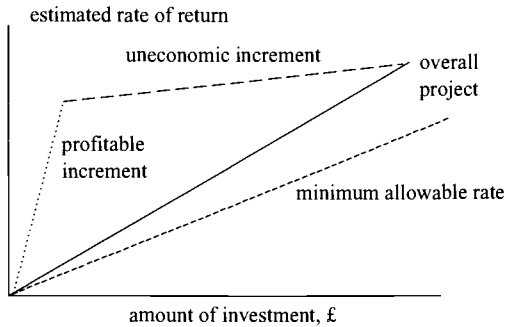

Figure 8.20 How an overall project may contain uneconomic increments

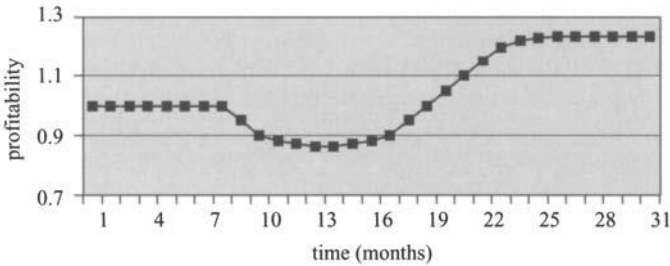

Figure 8.21 Typical time to obtain project benefits for a major project

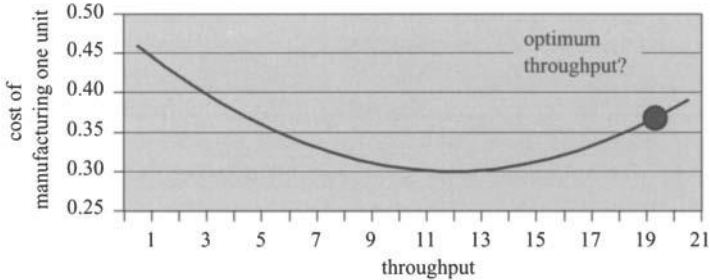

Figure 8.22 Matching throughput to market conditions

compromise between high yield and high throughput. Such problems arise across a wide range of applications from pharmaceuticals – where pushing production will usually lower yields from the expensive raw materials – to the scheduling of the speed for a supertanker carrying oil over several thousand miles – where high steaming speeds get the oil to market earlier but use a disproportionate amount of extra fuel in doing so. For all these cases, a market-dependent operating point, shown by the asterisk in Figure 8.22, needs to be chosen as yet another economic aspect of practical control.

Note: Further source material and suggestions for further reading to support the topics of Sections 8.1 to 8.3 will be found in Chapter 19. The references cited here are shown in support of Section 8.4.

8.5 References on methodologies for economic justification of investment in automation

- ALLEN, D.: ‘Economic evaluation of projects’ (Institute of Chemical Engineering, London, 1990)
- ANDERSON, J. S. and BRISK, M. L.: ‘Estimating the benefits of advanced process control’. Proceedings of IChem E symposium on *Advances in Process Control*, York, 1992
- BALDWIN, B.: ‘Economic justification of process improvement and automation projects’. IEEE Annual Textile, Fiber and Film Industry Technical Conference Greenville, S.C., 1997 pp. 1–5
- BRENNAN, D. J.: ‘Process industry economics’ (Institute of Chemical Engineering, London, 1997)
- BRISK, M. L.: ‘Process control: theories and profits’. Proceedings of IFAC Congress, Sydney, 1993, vol. 7, pp. 241–50
- CRAIG, I. K. and HENNING, R. G. D.: ‘Evaluation of advanced industrial control projects: a framework for determining economic benefits’ *Control Engineering Practice*, 2000, **8**(7), pp 769–80
- MARLIN, T. E., BRISK, M. L., BARTON, G. W. and PERKINS, J. D.: ‘Experiences from an industry-university study on control benefits’. Preprint of conference on Control Systems 2000, *Quantifying the Benefits of Process Control*, May 2000, pp. 5–9

Chapter 9

Linearisation

9.1 The motivation for linearisation

The most powerful tools for analysis and design of control systems operate only on linear models. It is therefore potentially very attractive when undertaking the design of a controller for a non-linear system to replace the non-linear system model by a linear approximation.

Questions that arise next are:

- What is meant by linearisation?
- How is it undertaken?
- To what extent are designs, produced using linear approximations, valid in practice when applied to the original non-linear system?

9.2 What is linearisation?

9.2.1 An initial trivial example

The volume V of a sphere is given by

$$V = 4\pi r^3/3$$

where r is the radius of the sphere

Suppose $r_0 = 10$ then $V = 4188.79$

Suppose $r_1 = 10.1$ then $V = 4315.7147$

Suppose $r_2 = 11$ then $V = 5575.27956$

These are the full solutions of the non-linear equation for three different r values.

To linearise the equation we operate as follows. Let $V = V_0 + \delta v$, $r = r_0 + \delta r$. Then

$$\begin{aligned} V_0 + \delta V_0 &= 4\pi(r_0 + \delta r)^3/3 \\ &= (4/3)\pi(r_0^3 + 3r_0^2\delta r + 3r_0\delta r^2 + \delta r^3) \end{aligned}$$

while from earlier

$$V_0 = 4\pi r_0^3/3$$

Subtracting the last equation from the one above yields

$$\delta v = \frac{4}{3}\pi(3r_0^2\delta r + 3r_0\delta r^2 + \delta r^3)$$

Linearisation consists in neglecting terms in δr^2 , δr^3 , etc., i.e.

$$\delta V = \frac{4}{3}\pi r_0^2 \delta r$$

and this result could have been obtained directly by using

$$\frac{dv}{dr} = \frac{4}{3}\pi r_0^2 \cong \frac{\delta v}{\delta r}$$

To complete this little illustration, we will see how good the approximations are for two cases, keeping $r_0 = 10$:

- (i) when $r_1 = 10.1$, $\delta r = 0.1$, $\delta V = 4\pi(10)^2 0.1 = 125.6637$ yielding $V_1 = V_0 + \delta V = 4314.45$ (true solution = 4315.7147)
- (ii) when $r_2 = 11$, $\delta r = 1$, $\delta V = 4\pi(10)^2 1 = 125.66$ yielding $V_2 = V_0 + \delta V = 5445.28$ (true solution = 5575.28).

Clearly, as the perturbation (in this case δr) moves further from the point about which linearisation is performed (in this case r_0) the approximation becomes less valid.

9.2.2 *Comments*

Thus linearisation, which we shall discuss in more depth below:

- (a) amounts to a local approximation of differentiable functions by derivatives;
- (b) is only valid for small perturbations.

However, and this is a point of considerable practical importance, we can overcome problem (b) to a considerable extent by linearising a function, not about some constant value (Figure 9.1a) but rather about a nominal solution that is expected to be followed approximately (Figure 9.1b).

An interesting side-question now arises. Suppose that the linearised equation is itself generating the solution about which successive linearisations are being performed (Figure 9.1c). If the perturbations are too large, the accuracy of the linearisation will be poor, and the generated solution will be invalid and the errors will be cumulative, so that the whole approach will fail. This leads to the topic of

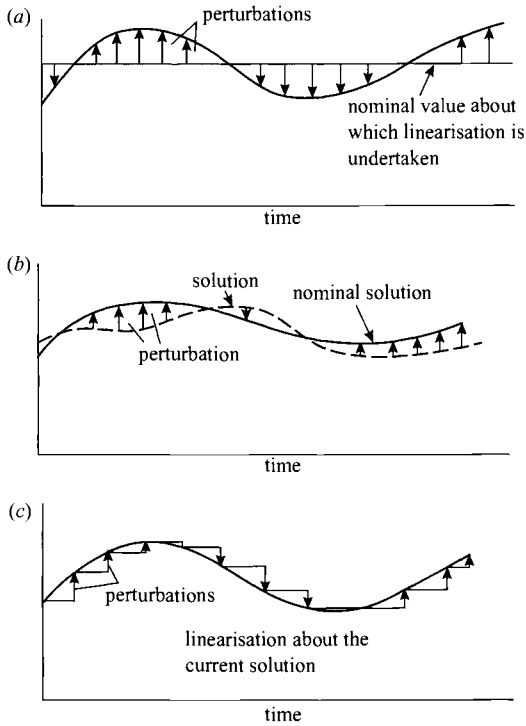

Figure 9.1 a Linearisation about a constant value
 b Linearisation about a nominal solution
 c Linearisation about the current solution

numerical solution of differential equations where, in general, it is not found efficient to use linearisation but rather to use several more terms (say four) of the Taylor series approximation of a non-linear function to produce the Runge–Kutta approach to the numerical solution.

9.3 Linearisation about a nominal trajectory: illustration

Let the equation

$$\dot{x} = f(x) + g(u)$$

represent a non-linear industrial process that repeats the same routine day after day. Each day it receives a nominal input $u_N(t)$, in response to which it produces a nominal output $x_N(t)$, Figure 9.2a. Linearisation about the nominal trajectories consists in producing the perturbation equation

$$\delta\dot{x} = \left. \frac{\partial f}{\partial x} \right|_{x=x_N(t)} \delta x + \left. \frac{\partial g}{\partial u} \right|_{u=u_N(t)} \delta u$$

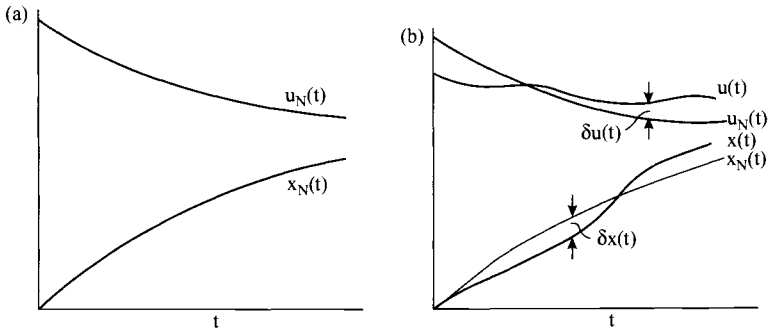

Figure 9.2 a The nominal input $u_N(t)$ provokes the nominal response $x_N(t)$
 b Perturbation about the nominal trajectories

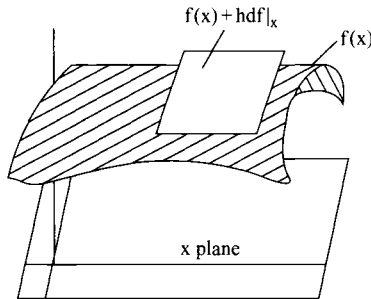

Figure 9.3 The derivative approximates the function f locally by the tangent plane shown

This linear equation models the process behaviour about the nominal trajectories (Figure 9.2b).

In practice, the nominal trajectories will often be taken as the mean of a large number of typical performances. Any individual performance can then be modelled as $x(t) = x_N(t) +$ the solution of the perturbation equation.

9.4 The derivative as best linear approximation

We can, if we wish, define the derivative of a function $f(x)$ as the unique linear function $df|_x$ that best approximates f near to x (Figure 9.3).

In the usual system of coordinates, the linear transformation df has the matrix

$$F = \begin{bmatrix} (\partial f_1/\partial x_1), & \dots, & (\partial f_1/\partial x_n) \\ \dots & \dots & \dots \\ (\partial f_n/\partial x_1), & \dots, & (\partial f_n/\partial x_n) \end{bmatrix}$$

which is called the Jacobian matrix of f at x .

The goodness of the approximation depends on $df|_x$. If $df|_x$ is non-zero then in general the approximation is good.

9A The inverse function theorem

The inverse function theorem gives an interesting view of approximation. It says that, if the derivative df of f at x has an inverse then so locally does f : i.e. in some region U in x there exists a function g such that

$$g(f(x)) = x \text{ for all } x \text{ in } U$$

$$f(g(y)) = y \text{ for all } y \text{ in } V$$

i.e. f has an inverse g on the restricted regions U, V .

Within the regions U, V we can replace the x coordinates by the corresponding y coordinates (see Poston and Stewart, 1976, p. 9) and then over the region U the function f is completely linearised without approximation. However, if df is not invertible (tested by checking for singularity of the Jacobian matrix) then such an approximation is not possible. Overall, the following result holds. If f has a non-zero gradient at x then we can find a smooth change of coordinates in some ball U around x by which the expression of f on u becomes linear.

Where the gradient is zero, the Jacobian is, by definition, zero and approximation has to be carried out by relying on the matrix of second derivatives, i.e. on the Hessian matrix H .

As can be seen in Figure 9.4, the nonlinear function $\sin x$ can be well approximated at $x = 0$ (by the linearisation $y = 2x$) but at $x = \pi/8$, the linear approximation $y = 1$ is poor because the Jacobian is zero there.

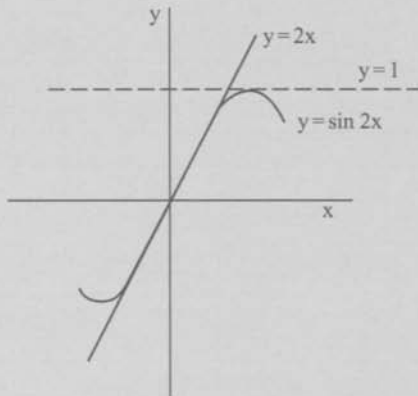

Figure 9.4 The curve $y = \sin 2x$ is well approximated by its first derivative $y = 2x$ at $x = 0$. At $x = \pi/8$ we have as linear approximation $y = \sin \pi/4 + 0 = 1$, a poor approximation

9B The concept of transversality

When a line pierces a plane a slight variation in either the line or the plane will not affect the nature of the intersection. However, if a line touches a plane tangentially then slight variations will affect the nature of the meeting, resulting in, for example, two-piercing of the plane, or no meeting with the plane at all (see Figure 9.5). These ideas, which are closely connected with catastrophe theory, have obvious connections with robustness as defined in terms of insensitivity to parameter changes.

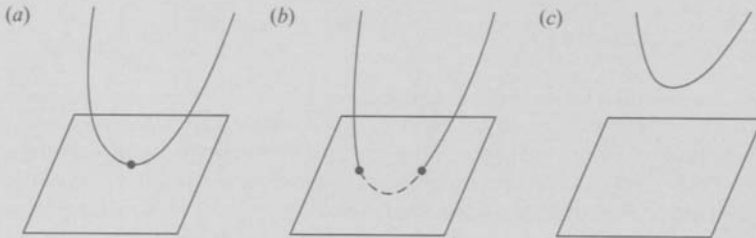

Figure 9.5 (a) As a typical situation in three dimensional space – a loop touches a plane tangentially. (b, c) Typical situations in three dimensional space – a line (b) pierces the plane in two places, (c) fails to meet the plane

Chapter 10

Multivariable linear processes

10.1 Transfer function representations

By a multivariable process we mean a process with several (say r) inputs and several (say m) outputs (Figure 10.1). In general, every input is connected to every output through some dynamic coupling. We can pretend that the i th output y_i is connected to the j th input u_j through a transfer function $g_{ij}(s)$. Because of our assumption of linearity, superposition is valid and therefore we can write

$$y_i(s) = \sum_{j=1}^r g_{ij}(s)u_j(s) \quad (10.1)$$

or

$$\begin{pmatrix} y_1(s) \\ \vdots \\ y_m(s) \end{pmatrix} = (g_{ij}(s)) \begin{pmatrix} u_1(s) \\ \vdots \\ u_r(s) \end{pmatrix}$$

where the notation $(g_{ij}(s))$ indicates the matrix

$$\begin{pmatrix} g_{11}(s) & \dots & g_{1r}(s) \\ \dots & & \dots \\ g_{m1}(s) & \dots & g_{mr}(s) \end{pmatrix}$$

Multivariable matrix formulations are used for control system design, particularly using the inverse Nyquist array methods pioneered by Rosenbrock (1971, 1974) and



Figure 10.1 A multivariate process: a system with r inputs and m outputs

Macfarlane (1970). The methods make central use of the concept of diagonal dominance. A completely diagonal matrix of transfer functions (with zeros everywhere except on the leading diagonal) would clearly indicate just a set of non-interconnected single-input single-output systems – each such system could be dealt with separately and there would be no need for any special ‘multivariable’ treatment.

In practice, multivariable closed loop systems can rarely be diagonalised for all frequencies by choice of controller. However, they can be made diagonally dominant; that is, the diagonal terms can be made large compared with the off-diagonal terms. It is a key result of Rosenbrock that interaction between a set of individually stable diagonal elements will not cause overall instability, provided that the overall matrix is diagonally dominant. (This result rests on Gershgorin’s theorem from linear algebra. The theorem allows bounds to be set on the location of eigenvalues.)

10.2 State space representations

In the state space modelling of linear systems it is assumed that there exists an n th order vector called the state vector, whose value at every instant of time completely characterises the dynamic state of the system. The order n is, in general, equal to the sum of the orders of all the individual differential equations that together describe the system.

Every single-input single-output linear system can of course be described in state space form and we choose such a system to illustrate some simple state space ideas. Let the single-input single-output process be

$$\frac{d^3y}{dt^3} + \frac{2d^2y}{dt^2} + \frac{3dy}{dt} + 4y = u \quad (10.2)$$

To move to a state space model we let

$$\begin{aligned} x_1 &= y \\ x_2 &= \dot{x}_1 \\ x_3 &= \dot{x}_2 \end{aligned}$$

Then, equivalent to eqn. 10.2, we can write

$$\begin{aligned} \dot{x}_1 &= x_2 \\ \dot{x}_2 &= x_3 \\ \dot{x}_3 &= -4x_1 - 3x_2 - 2x_3 + u \end{aligned}$$

This is the state space form. It would more usually be written

$$\begin{pmatrix} \dot{x}_1 \\ \dot{x}_2 \\ \dot{x}_3 \end{pmatrix} = \begin{pmatrix} 0 & 1 & 0 \\ 0 & 0 & 1 \\ -4 & -3 & -2 \end{pmatrix} \begin{pmatrix} x_1 \\ x_2 \\ x_3 \end{pmatrix} + \begin{pmatrix} 0 \\ 0 \\ 1 \end{pmatrix} u$$

$$y = (1 \quad 0 \quad 0) \begin{pmatrix} x_1 \\ x_2 \\ x_3 \end{pmatrix}$$

which is usually written

$$\left. \begin{aligned} \dot{x} &= Ax + Bu \\ y &= Cx \end{aligned} \right\} \quad (10.3)$$

and this formulation is the same for all multivariable linear systems.

10.3 Design of feedback control systems

A is called the system matrix and it is the main governor of systems behaviour. By setting

$$u = D(x + v) \quad (10.4)$$

we obtain

$$\dot{x} = Ax + BDx + Dv = (A + BD)x + Dv \quad (10.5)$$

The new system matrix can be seen to be $A + BD$ rather than A , as it was before feedback control was incorporated. It is easy to show that, for most systems, the matrix $A + BD$ can be chosen to give any performance that we desire by choice of D above (assuming A , B fixed). This idea is the basis for much of state variable feedback design.

10.4 Time solution of the state space equation

Let us set $u = 0$ in eqn. 10.3 and agree to concentrate on solving the resulting equation

$$\dot{x} = Ax \quad (10.6)$$

with $x(0) = x_0$ given (since $y = x_1$, we do not need to consider y separately).

Although x is an n vector and A an $n \times n$ matrix we can, remarkably, solve the equation just as though it were a scalar equation and write

$$x(t) = \exp(At) x(0) \quad (10.7)$$

Provided that we define what we mean by $\exp(At)$, we can reasonably expect that

$$\exp(At) = I + At + \frac{A^2 t^2}{2!} + \dots \quad (10.8)$$

i.e. a series expansion with I being the n th order identity matrix.

Also if we Laplace transform eqn. 10.6 we obtain

$$sx(s) - x(0) = Ax(s) \quad (10.9)$$

from which

$$x(t) = \mathcal{L}^{-1}\{(sI - A)^{-1}\}x(0) \quad (10.10)$$

where \mathcal{L}^{-1} indicates the operation of inverse Laplace transformation.

Under the (widely applicable) assumption that the solution of eqn. 10.6 must be unique, it becomes clear that

$$\exp(At) = \mathcal{L}^{-1}\{(sI - A)^{-1}\} \quad (10.11)$$

Equation 10.11 is useful in the solution of the state variable equation

$$\dot{x} = Ax + Bu \quad (10.12)$$

by Laplace transform methods.

Solution of the equation $\dot{x} = Ax + Bu$ in the time domain.

If eqn. 10.12 is well posed, then it possesses a unique solution. This solution is

$$x(t) = \exp A(t - t_0)x(t_0) + \int_{t_0}^t \exp A(t - t_0 - \tau) Bu(\tau) d\tau \quad (10.13)$$

Proof: Differentiate eqn. 10.13 to yield

$$\begin{aligned} \dot{x}(t) &= A \exp A(t - t_0)x(t_0) \\ &+ A \int_{t_0}^t \exp A(t - t_0 - \tau) Bu(\tau) d\tau \\ &+ \exp A(t - t_0 - (t - t_0))Bu(t) \end{aligned} \quad (10.14)$$

Substitute eqn. 10.13 into 10.14 to yield

$$\dot{x}(t) = Ax(t) + Bu(t)$$

as required.

A final interesting point about the solution

$$x(t) = \exp(At)x(0)$$

Because of the nature of the state vector (that at any time it completely characterises the dynamic state of the system) and because of the nature of the operator $\exp(At)$ it forms a transformation semi-group whose members, say T , have the property that

$$T(t_1 + t_2) = T(t_1) + T(t_2) \quad (10.15)$$

where t_1, t_2 are two different time intervals.

What all this means is that

$$x(t_1) = \exp(At_1)x(0)$$

$$x(t_2) = \exp(At_2)x(0) = \exp(A(t_2 - t_1))x(t_1)$$

If we choose times separated by a constant interval T then we can write

$$x(T) = \exp(AT) x(0)$$

$$x(2T) = \exp(AT) x(T)$$

and in general

$$x(kT) = \exp(AT) x((k-1)T) \quad (10.16)$$

Thus, once we have calculated the matrix $\exp(AT)$ (for some chosen small time interval T) we can generate the whole time solution to eqn. 10.12 by repetitive multiplication by the constant matrix $\exp(AT)$. See Moler (1978) for a review of alternative ways of calculating the transition matrix.

10A It seems remarkable that an oscillatory solution can be generated by repeated multiplication by a constant matrix (see Figure 10.2)

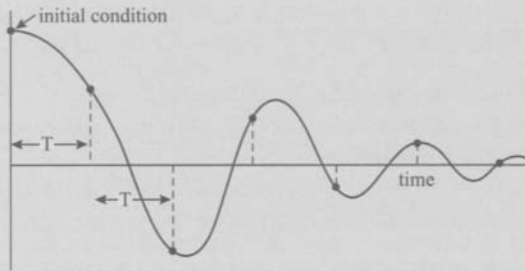

Figure 10.2 The points marked on the transient solution form a time series that can be generated by repeatedly multiplying the initial condition vector by a constant transition matrix

10.5 Discrete and continuous time models: a unified approach

The continuous time model

$$\dot{x} = Ax + Bu \quad (10.17)$$

has the unique continuous time solution

$$x(t_2) = \Phi(t_2 - t_1)x(t_1) + \Psi(t_2 - t_1)u(t_1) \quad (10.18)$$

provided that $u(t)$ is constant on the interval (t_1, t_2) . (It is also assumed that certain very general conditions for the well-posedness of differential equations are satisfied.)

Although eqn. 10.18 is valid for any choice of t_1, t_2 , i.e. it is as we have said a continuous time solution, it is of course possible to determine the solution only at intervals of time T seconds apart, i.e.

$$x(kT) = \Phi(T)x((k-1)T) + \Psi(T)u((k-1)T) \quad (10.19)$$

or if the interval T is assumed rather than being explicitly written

$$x(k) = \Phi(T)x(k-1) + \Psi(T)u(k-1) \quad (10.20)$$

This model can be considered to represent:

- (i) The exact behaviour of eqn. 10.17, provided that u is constant on every interval of length T . This will occur if u is generated by a computer updating at intervals T . Notice that the real solution exists at all times, whereas eqn. 10.17 produces information only every T seconds.
- (ii) The approximate behaviour of eqn. 10.17 under conditions where u does not satisfy the constancy condition.
- (iii) A difference equation that is an exact model for some inherently discrete time process. Such a difference equation may be set up and identified numerically for a discrete time system without any recourse to continuous time models.

We are pointing out, amongst other things, that the numerical solution of a differential equation is inevitably a difference equation. This difference equation may be viewed in the three different ways cited above.

The Z transform (see Chapter 11) may usefully be applied to multivariable discrete time models to yield alternative derivations of the expressions derived above.

10B Generation of a control sequence

Suppose that we wish to generate a control sequence to drive the state x in eqn. 10.20 from a given state $x(0)$ to a given desired state x_d for some particular value of k .

In eqn. 10.20, let us agree to set

$$A = \Phi(T), \quad B = \Psi(T)$$

Then we can write

$$\begin{aligned} x(1) &= Ax(0) + Bu(0) \\ x(2) &= Ax(1) + Bu(1) \\ &= A(Ax(0) + Bu(0)) + Bu(1) \end{aligned}$$

and in general

$$x(k) = A^k x(0) + [B, AB, A^2 B, \dots, A^{k-1} B] \begin{bmatrix} u(k-1) \\ \vdots \\ u(0) \end{bmatrix}$$

and, provided that invertibility obtains,

$$\begin{bmatrix} u(k-1) \\ \vdots \\ u(0) \end{bmatrix} = [B, AB, \dots, A^{k-1}B]^{-1} (x(k) - A^k x(0))$$

If $x(k)$ is replaced by the desired state x_d then an algorithm for generating a control sequence results:

$$\begin{bmatrix} u(k-1) \\ \vdots \\ u(0) \end{bmatrix} = [B, \dots, A^{k-1}B]^{-1} (x_d - A^k x(0)) \quad (10.21)$$

10.6 The concept of controllability for multivariable systems

Assume that the output y of a linear single-input single-output system can be driven to some arbitrary point y by choice of input u over some time period. Then, by the definition of linearity, the output y can be driven to every point in \mathbb{R}^1 by suitable choice of u over some time period.

For an n dimensional multivariable system, the state x may not necessarily be able to be forced to every point in \mathbb{R}^n , no matter what control input is applied. A system where x cannot be forced to every point in its own state space is called an uncontrollable system.

10C Conservation of dimension under linear transformations

Let $L : P \rightarrow Q$ be a linear transformation from

$$P = \mathbb{R}^n \text{ to } Q = \mathbb{R}^n$$

Dom L is defined as the subspace of P on which the transformation operates.

Range L is defined as the subspace of Q satisfying

$$\text{Range } L = \{Lx | x \in \text{dom } L\}$$

Ker L is defined as the subspace of P satisfying

$$\text{Ker } L = \{x | Lx = 0\}$$

Then the conservation of dimension insists that

$$\dim(\text{Range } L) + \dim(\text{ker } L) = \dim(\text{dom } L)$$

This means that the dimensionality of the range of the transformation L may be less than the dimensionality of the domain. Such a situation will occur whenever $\dim(\text{Ker } L) > 0$.

This 'loss of dimension into the kernel' is exactly the mechanism by which a system becomes uncontrollable. Tests for controllability amount to tests for ensuring that $\dim(\text{ker } L) = 0$, where the transformation L is constructed so as to represent the operation of mapping $x(0)$ into $x(t)$. In this we have

$$L(x(0), u(\tau), I) : x(0) \rightarrow x(t)$$

i.e. the mapping depends on $x(0)$ and on the particular function u defined on the interval $I = [t_0, t]$. The actual tests for controllability have been derived from linear algebra. See Chen (1984) for detailed descriptions of the techniques.

In a system that is not controllable, there are some states that cannot be reached in finite time by any control strategy. In fact some subsets of the state ((iii) and (iv) in Figure 10.3), cannot be influenced by the input.

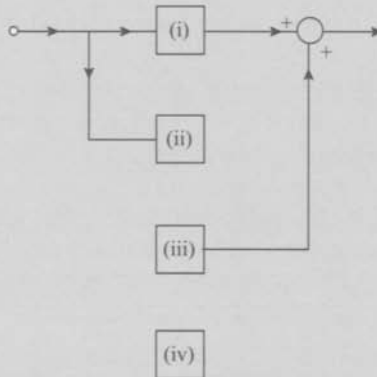

Figure 10.3 Every linear system can be decomposed into four blocks:

- (i) Controllable and observable
- (ii) Controllable but not observable
- (iii) Observable but not controllable
- (iv) Neither controllable nor observable

Observability is a dual of controllability. It is concerned with the question: does measurement of the output y of a system allow complete knowledge of the state vector to be determined?

An interesting view, due to Kalman, sees every system as representable by four blocks. The idea is illustrated in Figure 10.3.

Chapter 11

Discrete time and computer control

11.1 Computers as system components – devices that can change their state only at discrete times

A system that can change its state only at discrete points in time is called a discrete time system. Amongst the many examples of discrete time systems in everyday life could be mentioned the rates of exchange for foreign currencies charged by retail banks. Typically, these rates may be updated once every working day and stay constant otherwise.

Computers are the discrete time systems that interest us here; in particular, computers that perform the same calculation repeatedly. Such computers are used as controllers within closed loop systems. It turns out, perhaps surprisingly, that the discrete time effects of a computer, when used as a controller, are sufficiently profound to require a whole new batch of design techniques – these are introduced in this chapter.

To get a feel for what is going on, let us look at a very simple control loop first not containing a computer (case A) and secondly, containing a computer (case B).

The control loop (case A) simply comprises an integrator with negative feedback (Figure 11.1). Everything is at rest and set at zero and then v is moved instantaneously from $v = 0$ to $v = 1$. Simple calculation will show that the system output y moves as shown (Figure 11.2).

In case B a computer ‘looks at’ the signal e every 1.5 s, multiplies this signal by unity and puts this out to the integrator where it remains constant for 1.5 s.

Essentially, cases A, B differ only in the interposition of a discrete time device in case B (Figure 11.3). To work out the response, we note that over the first 1.5 s

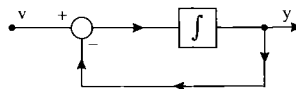

Figure 11.1 A continuous typical feedback loop with an integrator in the forward path (Case A)

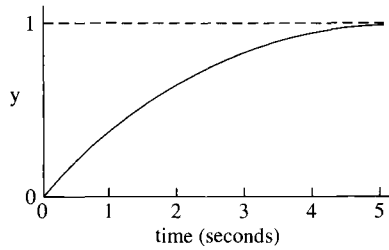

Figure 11.2 The step response of the system of Figure 11.1

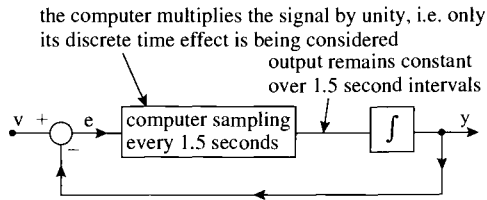

Figure 11.3 The system of Figure 11.1 with the addition of a computer that multiplies by unity and has a sampling interval of 1.5 s

period the input to the integrator is fixed at $v = 1$. Thus

$$y(t)|_{t=1.5} = \int_0^{1.5} e(t) dt = \int_0^{1.5} dt = 1.5$$

$$e(t)|_{t=1.5} = v(t)|_{t=1.5} - y(t)|_{t=1.5} = 1 - 1.5 = -0.5$$

and

$$y(t)|_{t=3} = \int_{1.5}^3 -0.5 dt + 1.5 = 0.75$$

and the response $y(t)$ is as shown in Figure 11.4. The significant differences between the responses 11.2, 11.4 are due entirely to the effects of sampling.

11A A simple and informative laboratory experiment

It forms an interesting laboratory demonstration to reproduce the results of Figures 11.1 to 11.4 experimentally and then to vary the sampling interval of the computer, which is only a sample and hold device in reality, and observe the results. As the sampling interval is increased, instability will eventually occur. The demonstration can then be enhanced by connecting in a frequency response analyser to determine approximately the phase shift characteristics of the computer as a function of applied frequency. A Bode plot check on stability will, very satisfyingly, be found to agree with experimental findings.

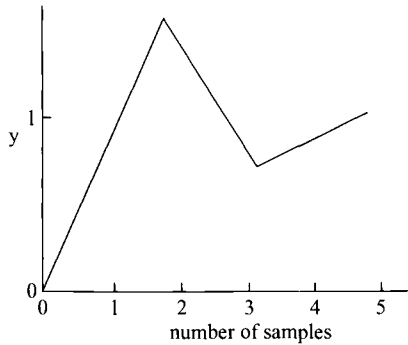

Figure 11.4 The step response of the system of Figure 11.3

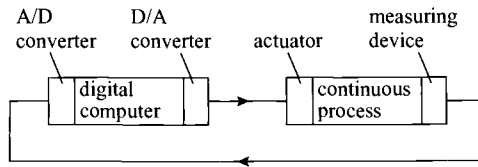

Figure 11.5 A continuous process under digital control

11.2 Discrete time algorithms

In this chapter, we are concerned with the discrete time control of continuous time processes (Figure 11.5). A discrete-time algorithm is an algorithm that operates on a sequence of error signals to produce a sequence of command signals. The importance of discrete-time algorithms lies in the fact that they are directly realisable in a digital computer controller. Such a digital controller samples the error at regular intervals of T seconds and produces a sequence of output commands, spaced at the same interval.

A continuous signal $e(t)$, when sampled every T seconds, is denoted e^* and the command sequence produced by a discrete-time controller is denoted u^* . The discrete-time command signal u^* must be converted into an analogue signal before being applied to a continuous process. Exact reconstruction of a continuous signal from samples is impossible to perform in real time since the reconstruction algorithm necessarily calls for unavailable future samples of the measured variable. Approximately correct reconstruction is possible but the necessary algorithms are relatively complex and they have undesirable frequency response characteristics. Usual practice for conversion of the command sequence u^* into a continuous signal is a very crude piece-wise constant approximation. The device that performs such reconstruction is a digital to analogue converter whose input is updated every T seconds. Seen as a mathematical component, rather than as a physical device, the operation of piece-wise constant reconstruction is equivalent to that of a zero order hold device.

11.3 Approaches to algorithm design

Roughly, there are two approaches to algorithm design.

Direct controller synthesis. Procedure in outline:

- (i) Convert the specification that the final system must meet into a desired transfer function $H(z)$. This step will very often involve a considerable amount of approximation – particularly in those frequently encountered cases where the original specification is expressed in terms far removed from those pertaining to transfer functions.

However, if the specification can be expressed in terms of a desired natural frequency and a desired damping factor then Figure 11.6 may be used directly to choose the poles of $H(z)$.

To use Figure 11.6 decide upon the required natural frequency ω_n , damping factor ξ , sampling interval T , and use the diagram to locate the intersection in the complex plane of the ω_n and the ξ loci. Suppose this intersection is at $a + jb$, then the poles of the sought-for transfer function $H(z)$ have to be located at $a + jb$. That is, the denominator of $H(z)$ should be $(z - a + jb)(z - a - jb)$.

Choice of the numerator of $H(z)$: In choosing the numerator of $H(z)$ the following factors need to be considered:

- (a) Steady state response
- (b) Frequency response
- (c) Physical reachability and computational time requirements for the controller $D(z)$.

Considering (a), recall that the steady response to a unit step, for stable H , is $H(z)$ as $z \rightarrow 1$. Considering (b), one point of view is that the response of $H(z)$

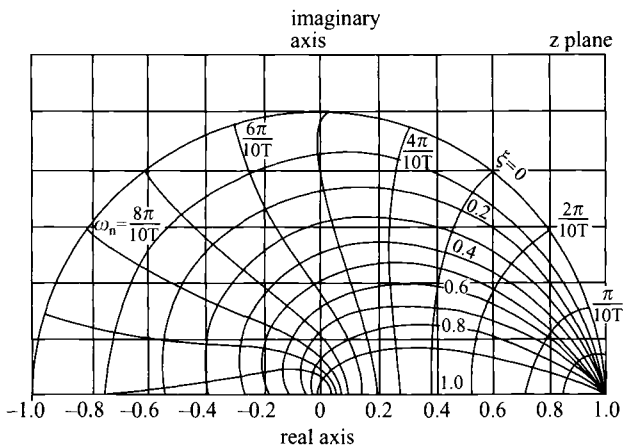

Figure 11.6 Diagram to assist in choosing the poles of $H(z)$

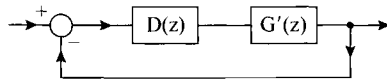

Figure 11.7 The combination of controller $D(z)$ and process + zero order hold $G'(z)$, in closed loop

when $\omega = \omega_s/2$ should be zero. Such behaviour can be obtained by placing one or more zeros at $z = 1$. Considering (c), notice that if the order of numerator and denominator of $D(z)$ are equal then 'instantaneous' calculation of control outputs is implied. Choosing the order of numerator in H to be one less than the order of the denominator allows one sampling period T for the control algorithm to be calculated.

- (ii) Produce a transfer function $G(s)$ representing the process that is to be controlled.
- (iii) Form the transfer function $G'(s) = G_0(s)G(s)$, where G_0 is a model of the interface between controller and process.
- (iv) Discretise the transfer function $G'(s)$ to produce the discrete time equivalent $G'(z)$.
- (v) Use the relation $D(z) = H(z)/\{G'(z)[1 - H(z)]\}$ to synthesise the necessary controller for insertion into the loop (see Figure 11.7).
- (vi) Convert $D(z)$ into a difference equation and use it as a real time algorithm.

11B A clever manipulation – how the digital to analogue convertor (zero order hold) is transferred for calculation purposes to become part of the process to be controlled

- (i) Notice carefully that in the approach described above, the digital to analogue convertor at the output of the controlling computer is grafted on to the process to form the artificial process G' , made up as $G'(s) = G_0(s)G(s)$.

The design procedure is thus to control G' rather than G . Thus, insofar as there are distortions caused in the analogue signal reconstruction at the digital to analogue convertor, they, being embodied in G' , will automatically be compensated during control algorithm design.

- (ii) Notice also that

$$\mathcal{Z}\{G_0(s)G(s)\} \neq \mathcal{Z}\{G_0(s)\}\mathcal{Z}\{G(s)\}$$

In fact,

$$\begin{aligned} \mathcal{Z}\{G_0(s)\} &= \mathcal{Z}\left(\frac{1 - \exp(-sT)}{s}\right) \\ &= \frac{(1 - z^{-1})z}{(z - 1)} = 1 \end{aligned}$$

i.e. a zero order hold unconnected to another analogue device is invisible to the Z transform.

Comment: It can be seen that the equation for $D(z)$ contains models both of the process and the desired behaviour. In effect, the controller cancels out the existing process characteristics and replaces them by those of the required system.

Gain plus compensation approach. Idea in outline:

- (i) If a controller consisting of only a simple gain of numerical value C is used as in Figure 11.8 then the performance of the resulting system (of transfer function $CG(z)/[1 + CG(z)]$) may be manipulated by choice of the value for C .
- (ii) As C is increased, the speed of response of the system increases but in general the response becomes oscillatory, and as C is increased further, the system becomes unstable.
- (iii) By incorporating a suitable compensator M into the loop (Figure 11.9) improved stability characteristics can be given to the loop and then the value of C can be further increased with a consequent increase in speed of response. This process of juggling the design of compensator M and the value of gain C can be iterated until a best possible response is achieved.

The compensator M primarily needs to improve the stability margin of the loop hence allowing higher gain C to be used, resulting in faster response. M may be an approximate differentiator, as in the three term controller (the three parallel terms are again C , a differentiator D and an integrator I that is present to remove steady state error).

Three term controllers are favoured by practitioners on grounds of: one form of controller satisfies all applications; the controller is easily ‘tuned’ for application using Ziegler–Nichols rules (see Section 8.2.1); the controller is a successful work-horse being applied in huge numbers across the industry.

Seen from a frequency response point of view, the compensator M is a phase-advance network and frequency response techniques, usually used in the s domain, allow the design to be matched to the application.

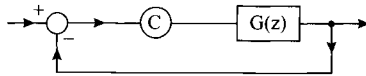

Figure 11.8 *A controller consisting of a simple gain C in a discrete time loop*

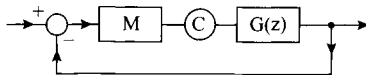

Figure 11.9 *Incorporation of a compensator into the loop of Figure 11.8*

- (iv) Discretise the *MC* combination to be directly implementable in a digital computer.

11C Takahashi's algorithm

In representing a typical process by discrete data points (assuming that a constant value of sampling interval T is to be used), in order to capture the all important initial curvature, a rather short value of T is indicated. However, in order to capture the (also important) final value, a large value of T is indicated – so that the number of points to be logged will not be excessive.

Takahashi solves this problem nicely by taking frequent samples initially in the step response and then using a formula to generate further points until the correct steady state is reached (Figure 11.10). Notice that these generated further points will not, in general, lie exactly on the curve.

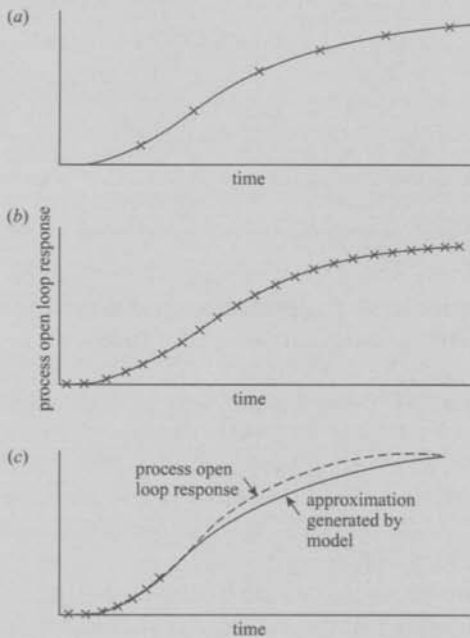

Figure 11.10 How many points are needed to capture a step response?

- Two few points fail to capture the essential shape
- Too many points to handle (bearing in mind that the order of the on-line algorithm will be the same as the number of points)
- Takahashi's approach. Early points capture the essential shape. Approximation (shown dotted) completes the response

Takahashi's algorithm then uses the model coefficients to synthesis a controller for the process (the one that generated the open loop step response) as follows (Figure 11.11): The model of form

$$G(z) = \sum_{i=1}^{n-1} g_i z^{-i} + \frac{g_n z^{-n}}{1 - p z^{-1}}$$

is fitted to the first n data points and the parameter p is fixed to give the correct steady state value and approximately correct decay rate. Takahashi then derived formulae (Takahashi et al. 1970) by which the $n + 1$ coefficients in the controller (Figure 11.11) may be calculated directly from the $n + 1$ model coefficients (g_1, \dots, g_n, p).

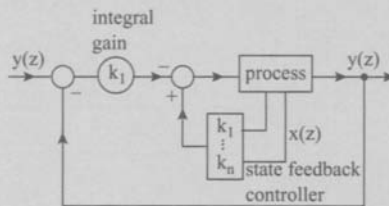

Figure 11.11 Takahashi's algorithm

11.4 Overview: concluding comments, guidelines for algorithm choice and some comments on procedure

- (i) Very broadly, there are two approaches to algorithm design. The first, synthesis of $D(z)$ to achieve a specific closed loop transfer function $H(z)$, is theoretically sound but suffers from two defects: choosing $H(z)$ usually involves massive approximation; $D(z)$ 'contains' both $G(z)$ and $H(z)$ and is therefore often unwieldy. The second approach, using a gain plus compensator, is not very scientific but it has the great merit of simplicity.
- (ii) Every continuous time algorithm can be discretised – this is one source of algorithms. Note, however, that the performance of a discretised algorithm is always degraded to some extent compared with that of the original continuous time algorithm. The extent of degradation is governed by the choice of sampling interval.

These are, however, discrete time algorithms that have no (apparent) continuous time equivalents. These are the most interesting algorithms and they tend to be incorporated as part of advanced control packages for solution of demanding problems.

- (iii) Some industries, like aerospace, tend predominantly to use frequency response continuous time design methods and only later to discretise. Process industries tend to use off-the-shelf three term algorithms integrated within diagnostic and monitoring supervisory software.

- (iv) In general, it is recommended to use simple solutions (for instance, off-the-shelf three term controllers) for routine problems. However, it is important to match the level of sophistication of the controller to the inherent difficulty of the problem.
- (v) Many alternative methods have been put forward for the selection of sampling interval T . The one suggested here, based on closed loop bandwidth, is a reasonable compromise between *ad hoc* methods and theoretical overkill.

11D Some difficulties in moving from differential equations to approximating difference equations

Suppose that we have a differential equation

$$\begin{aligned} y''' + 3y'' + 2y' + y &= 0 \\ y(0) = 10, y'(0) = 2, y''(0) &= 5 \end{aligned} \quad (11.1)$$

Suppose also that we have discretised the differential equation, by any suitable method, into the form

$$y(k) = ay(k-1) + by(k-2) + cy(k-3)$$

for some chosen time interval T and with numerical values being found for a, b, c .

Suppose finally that we wish to use the difference equation to generate an approximate numerical solution for the differential equation that it approximates. The differential equation has three initial conditions and the difference equation needs three starting values. However, it is not clear how to proceed or at least how to get started.

11E Discretisation

By discretisation, we mean the move from continuous to discrete time; differential equation to difference equation; s domain to z domain.

The most obvious approach to discretisation might appear to be replacement of s by its equivalent function in z . However, $z = \exp(st)$; hence the required substitution would be $s = (\ln z)/T$. Substitution would then produce an ugly polynomial in $\ln z$.

Discretisation methods that are actually used are:

- (i) Replacing derivatives dy/dt by their finite difference approximations

$$\begin{aligned} \frac{y_{k+1} - y_k}{T}, \frac{y_k - y_{k-1}}{T}, \\ \frac{\frac{y_{k+1} + y_k}{T} - \frac{y_k - y_{k-1}}{T}}{T} \end{aligned}$$

- (ii) Mapping the poles of a continuous transfer function $G(s)$ to the correct equivalent points in the z plane as dictated by the definition of z .

(iii) Using the relation

$$G(z) = \mathcal{Z}\{\mathcal{L}^{-1}(G(s))\}$$

(iv) converting $G(s)$ into multivariable $\{A, B, C\}$ form and using $\Phi(T), \Psi(T)$ as discrete operators (see Chapter 10 for more background).

(v) Using any numerical algorithm for the time solution of differential equations, for example, Runge-Kutta methods.

Discretisation needs care since it is easily possible for a stable $G(s)$ to be transformed into a $G(z)$ of quite different, even unstable, character.

11F A simple matter of quadratic behaviour

We investigate the problem: Given that $G(z)$ has the form

$$\frac{z - a}{(z - b)(z - 1)}$$

determine from first principles in the z plane the maximum value of C that does not produce instability in the loop (Figure 11.12).

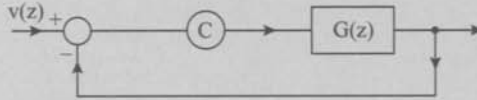

Figure 11.12 The closed loop system whose poles we study in this section

Approach: The loop has the z transform

$$\frac{C(G(z))}{1 + CG(z)} = \frac{C(z - a)}{(z - b)(z - 1) + C(z - a)}$$

We seek the largest value of C for which the roots of $1 + CG(z) = 0$ satisfy $|z| < 1$. Now, from an examination of the equation, we can see that as $C \rightarrow \infty$ the two solutions will have asymptotes $z \rightarrow \infty, z \rightarrow a$.

It could seem to the uninitiated that the value of C we are seeking might be the value of C that brings one root of the equation to $z = -1$?

Question: When will the simple stability test

$$1 + CG(z)|_{z=-1} = 0 \tag{11.2}$$

yield the required value of C ?

Test cases (Figure 11.13)

(1)
$$G(z) = \frac{z + 0.2}{(z - 0.3)(z - 1)}$$

(2)
$$G(z) = \frac{z + 0.2}{(z - 0.4)(z - 1)}$$

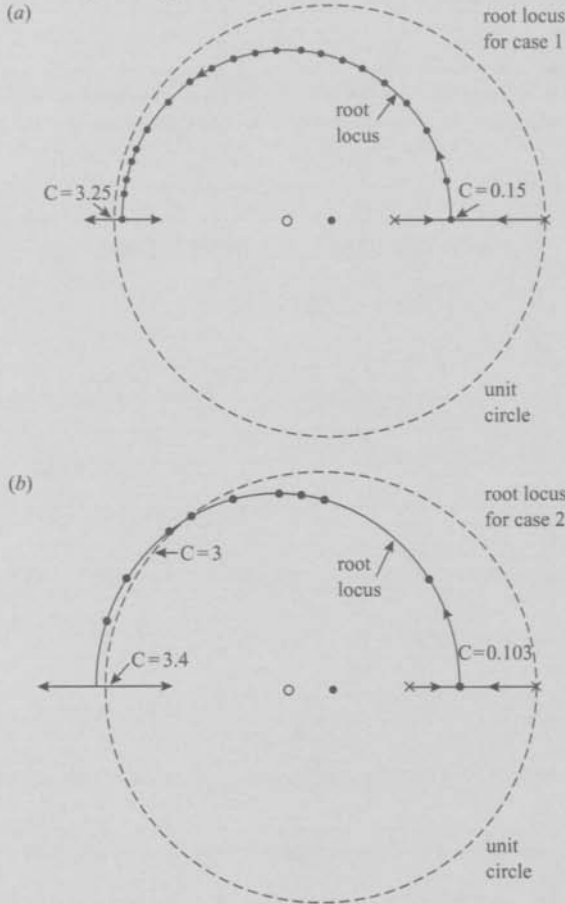

Figure 11.13 Root loci (upper halves only shown) for the system of Figure 11.12

a With $G(z) = (z + 0.2) / ((z - 0.3)(z - 1))$

b With $G(z) = (z + 0.2) / ((z - 0.4)(z - 1))$

The point to note from these diagrams is that in (a) the root locus leaves the unit circle at $z = -1$ whereas in (b), the locus enters the circle at that point - numerical checks on stability can be misleading unless the locus is drawn

Applying the simple test (eqn. 11.2) to the two cases leads respectively to the solutions:

$$(i) \quad z^2 - 1.3z + 0.3 + Cz + 0.2c \Big|_{z=1} = 0 \Rightarrow c = 3.25$$

$$(ii) \quad z^2 - 1.4z + 0.4 + Cz + 0.2c \Big|_{z=1} = 0 \Rightarrow c = 3.5$$

Case 1 with $C = 3.25$ leads to roots at $z = -0.95, z = -1$

Case 2 with $C = 3.5$ leads to roots at $z = -1, z = -1.1$,

i.e. for case 1 $C_m = 3.25$ is confirmed as correct but for case 2, we find that $C_m < 3.5$.

To investigate, we plot the loci of the roots of eqn. 11.11 as C varies. It is now clear that the difficulty in case 2 arises because the loci leave the unit circle at points where z has complex values. Calculation shows that this behaviour occurs whenever

$$a \leq -\left(\frac{1-b}{3+b}\right) \quad (11.3)$$

and that the value C_m of C at which the loci leave the unit circle is then

$$C_m = \frac{1-b}{|a|} \quad (11.4)$$

Using this equation we obtain the correct value of C_m for case 2 as $C_m = 3.0$. Of course, when the inequality 11.3 is not satisfied, C_m can be determined using eqn. 11.4.

Using only a knowledge of elementary quadratic equations, we have obtained an interesting insight into the behaviour of a closed loop discrete time system.

11G Continuous is not the limit of discrete as $T \rightarrow 0$

Consider the transfer function

$$G(s) = \frac{1}{s + 0.1}$$

The equivalent discrete time transform, obtained by taking the Z transform $\mathcal{L}^{-1}\{G(s)\}$ is

$$G(z) = \frac{z}{z - \exp(-0.1T)}$$

If we set T at some reasonable value, say $T = 1$, the behaviour of the inverse transform of $G(z)$ in the time domain approximates reasonably well the behaviour of the inverse transform of $G(s)$.

We might assume that as $T \rightarrow 0$, the approximation will improve until, in the limit, the two behaviours coincide. However, note that

$$G(z)|_{T \rightarrow 0} = \frac{z}{z - 1}$$

whose s domain equivalent is $1/s$, an integrator. (Attempts to investigate this effect by numerical methods tend to run into problems of word length.)

11H Non-uniqueness of inverse Z transforms

From the point of view of the Z transform, the three signals shown in Figure 11.14 are identical. This leads to many practical problems, since, if the signals are input to a system, the effect of the three signals will be markedly different. Similarly, a signal that is apparently constant, according to the transform, may actually be oscillating widely between sampling instants.

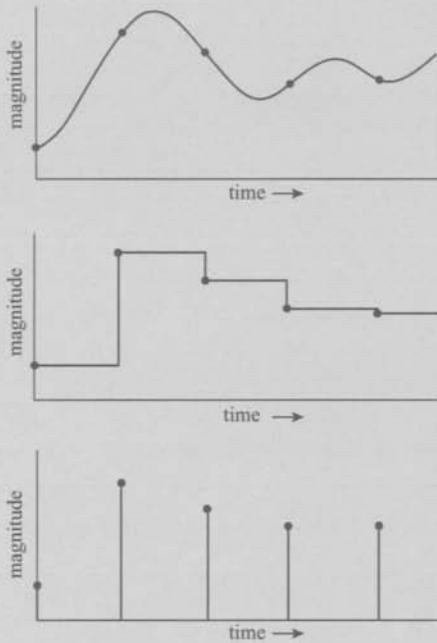

Figure 11.14 The three signals shown have identical Z transforms

11I Stability is normally considered to be a property of a system so that for any bounded input a stable system should produce a bounded output

Stability is normally considered to be an inherent property of a system so that, for any bounded input, a stable system should produce a bounded output.

However, note the following. A system of transfer function

$$G(z) = \frac{1}{z^2 + 1}$$

in response to a step $u(k) = \{1, 1, 1, \dots\}$ produces the bounded output

$$y(k) = \{0, 0, 1, 1, 0, 0, 1, 1, 0, 0, \dots\}$$

but in response to the input

$$u(k) = \{1, 0, -1, 0, 1, 0, -1, \dots\}$$

it produces the unbounded output

$$y(k) = \{0, 0, 1, 0, -2, 0, 3, 0, -4, 0, 5, 0, -6, 0, \dots\}$$

(Further investigation will show that the input for the second case has $u(z) = 1/(z^2 + 1)$ so that $G(z)u(z)$ has replaced poles on the unit circle.)

Chapter 12

**State estimation: the Kalman filter
and prediction**

12.1 State estimation – what it attempts to do

Many powerful feedback control strategies require the use of state feedback (Figure 12.1). However, in many important practical cases the state is not available to be fed back (it is said to be inaccessible). In such cases, a state estimator may be used to reconstruct the state from a measured output (Figure 12.2).

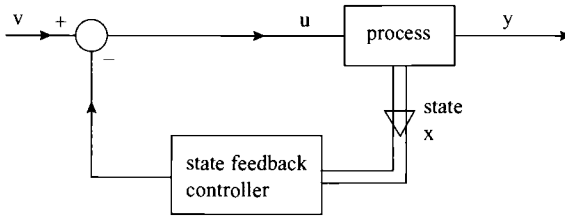

Figure 12.1 Application of state feedback

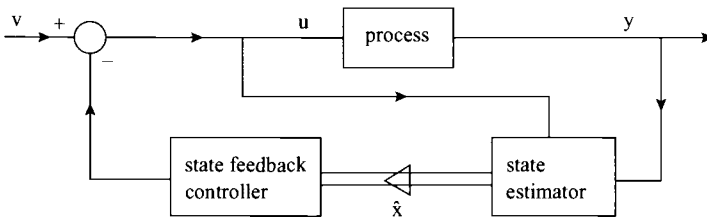

Figure 12.2 Application of state feedback when the state is inaccessible: a state estimator reconstructs an estimate \hat{x} of the true state x

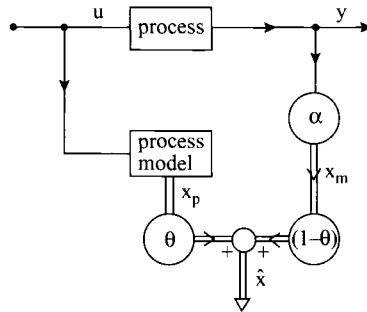

Figure 12.3 Simple illustration of the principle of the Kalman filter

12.2 How a state estimator works – the Kalman filter

We assume that at time $t = 0$, the state x is exactly known, with value x_0 . We have a process model that, given x_0 , can make a model-based prediction T seconds into the future, to yield the prediction $x_p(T)$.

We also have a measurement y and a known relation $x_m = \alpha y$, applying at all times. In particular we have $x_m(T) = \alpha y(T)$.

Both the model used for prediction and the measurement y are assumed to be subject to errors. Thus we have, at time T , two estimates of the true state $x(T)$. These are:

$x_p(T)$, predicted by a model

$x_m(T)$, based on measurement.

The best estimate of $x(T)$ is denoted $\hat{x}(T)$ and is determined by the relation

$$\hat{x}(T) = \theta x_p(T) + (1 - \theta)x_m(T)$$

where θ is a coefficient between 0 and 1 whose value is determined by the relative statistical confidence that can be placed in the accuracy of the model and of the measurement (see Figure 12.3).

A whole armoury of techniques, under the generic name Kalman filter, deals with all aspects of the application to different situations.

12.3 The Kalman filter – more detail

Figure 12.4 shows the Kalman filter connected to a process with inaccessible state vector $x(j)$. It is assumed that the process state and the measurement vector $y(j)$ are corrupted by Gaussian noises $w(j)$, $v(j)$ respectively, with diagonal covariance matrices Q , R .

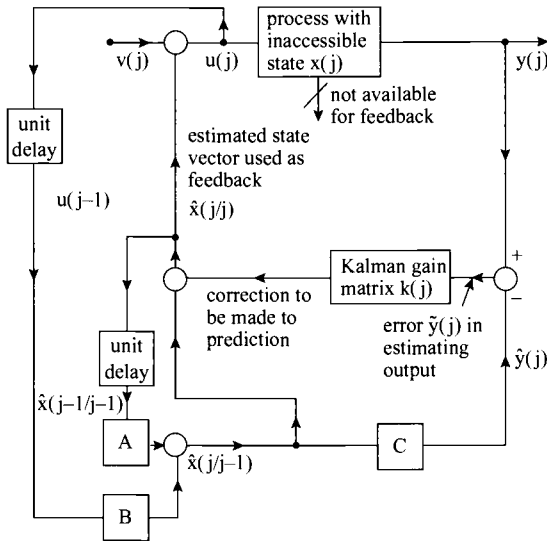

Figure 12.4 The Kalman filter connected to a process with inaccessible state so as to feed back an estimate of the process state for closed loop control

The process is assumed to have the model:

$$\left. \begin{aligned} x(j) &= Ax(j-1) + Bu(j-1) + Ew(j-1) \\ y(j) &= Cx(j) + v(j) \end{aligned} \right\} \quad (12.1)$$

At time $t = (j-1)T$, the discrete-time, linear model $[A, B, C]$ is supplied with a previous best estimate of the state, designated as $\hat{x}(j-1/j-1)$ and with a measured value of $u(j-1)$. Then, using the equation

$$\left. \begin{aligned} \hat{x}(j/j-1) &= A\hat{x}(j-1/j-1) + Bu(j-1) \\ \hat{y}(j) &= C\hat{x}(j/j-1) \end{aligned} \right\} \quad (12.2)$$

a one step ahead prediction of the state and of the corresponding output is made. (Note that since w, v , are Gaussian, they have zero mean and hence do not appear in the prediction (eqn. 12.2).) When time $t = jT$ is reached, the output prediction error $\tilde{y}(j)$ can be calculated from the equation

$$\tilde{y}(j) = y(j) - \hat{y}(j) \quad (12.3)$$

Finally, we obtain the current best estimate $\hat{x}(j/j)$ by adding to the model prediction $\hat{x}(j/j-1)$, a correction term, proportional to $\tilde{y}(j)$, according to the equation

$$\hat{x}(j/j) = \hat{x}(j/j-1) + K(j)\tilde{y}(j) \quad (12.4)$$

$K(j)$ is called the *Kalman gain matrix* and it must be chosen so that the estimates $\hat{x}(j/j)$ are optimal in some sense. However, before considering optimality, it can

be seen from the block diagram that the Kalman gain is within a feedback loop and the wider question arises: will the sequence $[\hat{x}(j/j)]$ converge to $x(j)$. If so, how quickly will it converge? Will there be a bias in the estimate? How accurate must the process model be? What if the process is non-linear? How accurately must covariance matrices Q , R be specified? What if w , v are non-Gaussian? What time step T needs to be chosen for the discretisation? What if the process is time-varying or some of its parameters are not known *a priori*?

The practical questions will be considered later but now we return to the question of choosing the optimal gain matrix $K(j)$.

12.4 Obtaining the optimal gain matrix

From eqns. 12.3 and 12.4,

$$\hat{x}(j/j) = \hat{x}(j/j-1) + K(j)[y(j) - C\hat{x}(j/j-1)] \quad (12.5)$$

Then using eqn. 12.2

$$\begin{aligned} \hat{x}(j/j) &= A\hat{x}(j-1/j-1) + Bu(j-1) \\ &\quad + K(j)[y(j) - C\hat{x}(j/j-1)] \end{aligned} \quad (12.6)$$

The state estimation error is defined as:

$$\tilde{x}(j) = x(j) - \hat{x}(j/j) \quad (12.7)$$

but

$$x(j) = Ax(j-1) + Bu(j-1) + w(j-1) \quad (12.8)$$

and

$$\begin{aligned} y(j) &= Cx(j) + v(j) \\ &= C[Ax(j-1) + Bu(j-1) + w(j-1)] + v(j) \end{aligned} \quad (12.9)$$

Substituting eqn. 12.9 into eqn. 12.6 yields

$$\tilde{x}(j) = [I - K(j)C][A\tilde{x}(j-1) + Ew(j-1)] - K(j)v(j) \quad (12.10)$$

Define

$$P(j) = \mathcal{E}[\tilde{x}(j)\tilde{x}(j)^T]$$

where \mathcal{E} indicates expected value and where the superscript T indicates transpose. P is a covariance matrix that indicates the accuracy of the state estimation. The system of Figure 12.4 is linear and the disturbing signals are Gaussian. Under these conditions, the solution of eqn. 12.10 to yield the gain matrix $K(j)$ that minimises

the estimation error is yielded by application of classical optimal control theory. In fact the optimal estimation problem and the optimal control problem lead to the same equations, and for this reason the two problems are often considered to be duals.

After some manipulation whose detail is omitted (but see for instance Grover-Brown, 1992) the optimal gain matrix is found to be

$$K(j) = M(j)C^T (CM(j)C^T + R)^{-1}$$

where

$$M(j) = AP(j-1)A^T + EQE^T$$

$$P(j) = (I - K(j)C)M(j)$$

Notice that the equations for $K(j)$ contain no measured data and that therefore they may be solved for all values of j in advance, off-line, if need be.

The optimal state estimator is given by

$$\hat{x}(j|j) = (I - K(j)C)[A\hat{x}(j-1|j-1) + Bu(j-1)] + K(j)y(j)$$

and we can return to Figure 12.4, to understand how the algorithm is coupled in real time to the process whose state is to be estimated.

12.5 Prerequisites for successful application of the Kalman filter in the form shown in Figure 12.4

- (i) There must exist a 'sufficiently accurate' linear, discrete-time, time-invariant process model (A, B, C, E) .
- (ii) The disturbing noises v, w must be Gaussian with zero mean and their covariance matrices R, Q must be known.
- (iii) On-line computing power must be available, capable of performing the necessary calculations within a time interval that will usually be dictated by the process dynamics.

12.6 Discussion of points arising

- (i) *Time varying processes*: The Kalman filter theory is applicable directly to a time varying process $\{A(j), B(j), C(j), E(j)\}$.
- (ii) *Continuous time processes*: Most processes to which the Kalman filter is to be applied will operate in continuous time. Such processes must be approximated by discrete time models. The discretisation process is easily performed but care must be taken not to introduce serious errors into models during discretisation (see Leigh, 1987b, pp. 71–87).
- (iii) *Non-linear processes*: Most important processes are non-linear and the usual procedure is to use a different linear approximation $\{A(j), B(j), C(j), E(j)\}$

to represent the process at each time step jT . This procedure is equivalent to linearising about a time trajectory. The filter operating in the way described is usually referred to as the extended Kalman filter.

- (iv) *Complex processes*: The Kalman filter for a complex process will, of necessity, be based around a low-order approximation to the process.
- (v) *Processes that vary with time in unknown ways*: A process that is changing with time may have some or all of its model parameters estimated numerically in real time from measured process data. The procedure may be performed separately from the Kalman filtering operation. Alternatively, the required model parameters may be estimated, along with the process states, using the Kalman filter. In essence, such model parameter estimation is performed by relabelling as state variables those parameters that are to be estimated. Such relabelling clearly introduces artificial non-linearities into the process equations. These non-linearities are dealt with by linearisation in the same way as when the process equations are inherently non-linear.
- (vi) *Non-Gaussian disturbance signals*: A non-Gaussian signal (say, $r(z)$) can be treated by synthesising a filter transfer function (say $G(z)$) such that

$$r(z) = G(z)v(z)$$

where $v(z)$ is a white noise signal.

Thus, by adding a new element G to the process model, the requirement that v shall be a Gaussian signal of zero mean may be met. The element G used in this way is sometimes referred to as a colouring filter.

- (vii) *Disturbing signals v , w have covariance matrices R , Q that are unknown*: Experimental observation of signals may give some quantitative information on the numerical values for R , Q . Simulation studies of the Kalman filter coupled to a process model will usually give considerable guidance of the choice of R and Q since these matrices affect the convergence of the estimate of the state to its true value (the true value of the state is, of course, known in a simulation study). By performing simulation runs with different choices of R and Q , it is usually possible to choose compromise values that will yield good convergence over a wide range of conditions.

Use of the innovation sequence to modify R and Q

The sequence $\{\tilde{y}(j)\}$ is known as the innovation sequence. Under ideal conditions, when all the initially stated assumptions are satisfied, the innovation sequence will be Gaussian with zero mean. It therefore follows that bias or non-Gaussianness in the innovation sequence may be used in a corrective on-line feedback loop to modify parameters, for example in the colouring filter $G(z)$ described in section (vi) above.

12.7 Planning, forecasting and prediction

Almost every human activity is undertaken based on assumptions and expectations about the future. We choose a particular action from a set of possible actions in the

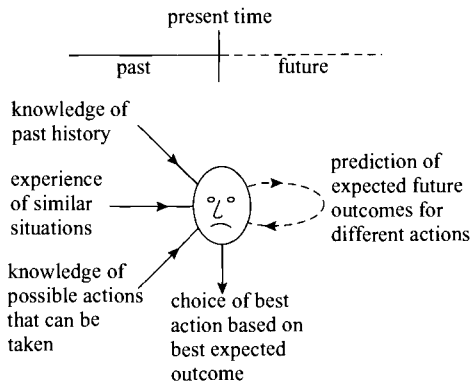

Figure 12.5 The broad idea of decision making

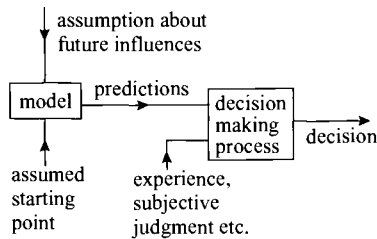

Figure 12.6 Model-assisted decision making

expectation that a particular outcome will result. In other words, before we decide on a course of action, we predict what the outcome will be. Good prediction is clearly a prerequisite for good decision making. This broad idea of decision making is illustrated in Figure 12.5 and the idea of model based predictions assisting decision making in Figure 12.6.

12.7.1 Approaches to prediction

Possibly the simplest approach to prediction is to extrapolate a curve of previous behaviour (Figure 12.7).

Such an approach has obvious limitations and obvious refinements are possible. For instance, known cyclic behaviour can be allowed for (an electricity generating utility attempting to forecast future demand will have access to previous records showing daily, weekly and annual cyclic demand variations).

Curve extrapolation can be mechanised in various ways. However, all these ways are passive, in the sense that they do not allow for any actions that we may wish to take to influence the future shape of the curve. The effect of actions on the future shape of the curve might be quantified by running a sufficient number of experiments in which different types and magnitudes of actions were taken. The inter-relations could

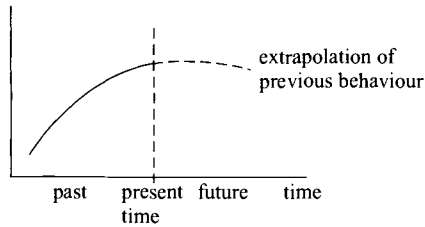

Figure 12.7 *Prediction by curve extrapolation*

then be determined by statistical means. Clearly different strategies for planting and fertilising crops could be evaluated in this way so that a model, based on wide-ranging experimentation, might guide full-scale growing strategies.

12.7.2 *Physically based models for prediction*

Lunar eclipses can be predicted with remarkable precision, far into the future, because the phenomena involved can be completely modelled by solvable deterministic equations having coefficients that are known numerically. All other phenomena that can be deterministically modelled in this way will also be completely predictable.

Thus, the outcome when two billiard balls collide is predictable because the mass, resilience and velocity of the balls are measurable properties and the laws governing elastic collisions are exactly known. If several million gas molecules obeying the same laws as billiard balls are involved in collisions, then, although in theory it would be possible to model each individual collision, it will in practice be necessary to predict the future aggregate behaviour as described by a small number of statistical variables. Conversely, predicting the weather, the price of oil, the exchange rate of the pound sterling against the dollar, the stock market index, the efficiency of a new drug or the financial viability of a new business venture are all extremely difficult, but nonetheless all are undertaken intensively throughout the world as an essential prerequisite to significant decisions of one sort or another.

12.8 **Predictive control**

Coales and Noton (1956) pioneered an approach in which a fast on-line model of a process generated control actions for application to the real process. The strategy can produce performances close to time-optimal for the control of switched systems. Since then a whole range of model-based control strategies has emerged; see Section 19.15 for key references to this area.

Notes: Source material and suggestions for further reading to support the topics of this chapter will be found in Chapter 19. See in particular Section 19.6.

Chapter 13

Non-linearity

13.1 What is meant by non-linearity

If John gets 10 hectathrills by taking to a ball a lady aged 24 and of height 5 ft 5 ins, how many hectathrills would he obtain by taking to the same ball a lady of height 10 ft 10 ins and aged 48? (With apologies for the failure to use SI units and with acknowledgments to Linderholm, 1972.)

In the linear world, the relation between cause and effect is constant and the relation is quite independent of magnitude. For instance, if a force of 1 newton, applied to a mass m , causes the mass to accelerate at a rate a , then according to a linear model, a force of 100 newtons, applied to the same mass, will produce an acceleration of 100 a .

Strictly a linear function f must satisfy the following two conditions, where it is assumed that the function operates on inputs $u_1(t)$, $u_2(t)$, $u_1(t) + u_2(t)$, $\alpha u(t)$, where α is a scalar multiplier:

- (i) $f(u_1(t)) + f(u_2(t)) = f(u_1(t) + u_2(t))$
- (ii) $f(\alpha u_1(t)) = \alpha f(u_1(t))$.

Any system whose input–output characteristic does not satisfy the above conditions is classified as a non-linear system. Thus, there is no unifying feature present in non-linear systems except the absence of linearity. Non-linear systems sometimes may not be capable of analytic description; they may sometimes be discontinuous or they may contain well understood smooth mathematical functions.

The following statements are broadly true for non-linear systems:

- (i) Matrix and vector methods, transform methods, block-diagram algebra, frequency response methods, poles and zeros and root loci are all inapplicable.
- (ii) Available methods of analysis are concerned almost entirely with providing limited stability information.
- (iii) System design/synthesis methods scarcely exist.

- (iv) Numerical simulation of non-linear systems may yield results that are misleading or at least difficult to interpret. This is because, in general, the behaviour of a non-linear system is structurally different in different regions of state space (where state space X is defined for a non-linear system according to the equation

$$\dot{x} = f(x, u) \quad y = g(x) \quad \text{and } x \in X$$

where the n -dimensional state vector x can be visualised as being made available for control purposes by a non-linear observer with inputs u and y and with output \hat{x} where as usual the superscript \wedge indicates an estimated value).

Thus, the same system may be locally stable, unstable, heavily damped or oscillatory, according to the operating region in which it is tested. For a linear system, local and global behaviour are identical within a scaling factor – they are topologically the same. For a non-linear system it is in general meaningless to speak of global behaviour.

Very loosely, we can organise our thinking about non-linearity with the aid of Figure 13.1. This shows that:

- (a) very few systems are strictly linear
- (b) a larger class of systems is approximately linear
- (c) a strongly non-linear class exists
- (d) a class whose non-linearity is its most important characteristic exists and needs special consideration.

Linear methods will normally be applied to class (b) without any discussion.

Systems in class (c) will often be linearised to allow certain types of controller synthesis to be carried out. Checks by numerical simulation of the complete unapproximated system plus controller will then be used to determine whether the designs

(a) linear systems
(b) approximately linear systems
(c) strongly non-linear systems
(d) class of systems whose non-linearity is their most important characteristic

Figure 13.1 A loose classification of systems in terms of linearity/non-linearity

(based on linearised approximation) will be sufficiently valid in practice over a choice of envisaged operating conditions.

Systems in class (d) have their behaviour dominated by non-linearity. Such systems include:

- (i) Stable oscillators: Governed by continuous non-linear differential equations such as the van der Pol equation. This type of equation exhibits, for the right choice of parameters, limit cycle behaviour. This stable oscillatory behaviour, essentially non-linear in its origins, is very interesting and has been much studied (see Andronov *et al.*, 1973; van der Pol, 1927).
- (ii) Relay and switched systems: The systems appear deceptively simple, but, because of the discontinuous non-linearity, special techniques of analysis are required. Because switched systems are both cheap and high-performing, they are frequently applied in industry, even in situations for which they are not too well suited (see Tsien, 1954).
- (iii) A variety of systems exhibiting jump resonance, stick–slip motion, backlash and hysteresis: All of these phenomena can be present as insidious and persistent degraders of performance of control loops (see Gibson, 1963).

13.2 Approaches to the analysis of non-linear systems

As discussed in (ii) above, available methods of analysis are concerned almost entirely with providing stability information.

Lyapunov's second or direct method

Already described in Chapter 7, it is the only approach that involves no approximation. However, the information produced by application of the method is of limited value for system design. For instance, with the aid of the method, a control loop of guaranteed stability may be synthesised. This means that the designed system, if perturbed, will return to equilibrium – maybe in one second, maybe in 100 000 s or more. Information on actual performance is totally lacking.

Lyapunov's first method

A beautiful method that depends on local linearisation. It is summarised later in this chapter. Again, the method has little or no design applicability.

Describing function method (described later in this chapter)

This is a linearisation method in which sinusoidal analysis proceeds by the expedient of neglecting harmonics generated by the non-linearities. Thus the approximation consists in working only with the fundamental of any waveform generated. The describing function method can be a powerful design tool for a very restricted class of problems.

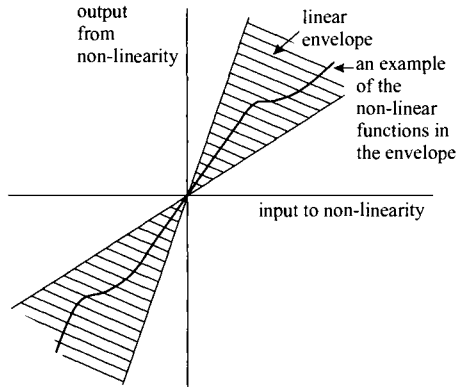

Figure 13.2 A linear envelope that bounds a class of (memoryless) non-linearities

Sector bound methods

A non-linear function f may be contained within two straight line boundaries. Each of these boundaries is a linear function (Figure 13.2). Envelope methods (a description that is by no means universal and which in fact may have been coined by the author) are based on the idea of ensuring system stability in the presence of any and every function that can reside in the envelope. Clearly the stability results obtained by envelope methods will be sufficient, but not necessary, conditions, since the worst case within the envelope has to be allowed for. Envelope methods are made more interesting by the existence of two famous conjectures. These are:

Aizerman's conjecture roughly states: Let S be a system containing a non-linearity that can be contained within the linear envelope, Figure 13.2. If when the non-linearity is replaced by any linear function within the sector as visualised in Figure 13.2, the resulting loop is stable, then the system S is itself stable. Aizerman's conjecture is false, as shown by counter-example.

Kalman's conjecture roughly states: If a system satisfies Aizerman's conjecture, together with additional reassuring constraints on derivatives, the system S will be stable. Kalman's conjecture is also false, as shown by counter-example (see Leigh, 1983*b*).

It is interesting to speculate on the reasons for the failure of the two conjectures. The easiest line of reasoning, although not necessarily correct, is that harmonics present in the sinusoidal response of the non-linear system have no counterpart in the linear systems that represent the bounds of the approximating sector.

13.3 The describing function method for analysis of control loops containing non-linearities

This method is specifically applicable to a closed loop containing dynamic non-linearities that can be decomposed into a non-linear non-dynamic block of gain $N(a)$

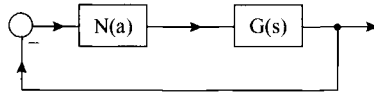

Figure 13.3 The loop containing a linear dynamic system and a non-linear non-dynamic system that is analysed by the describing function method

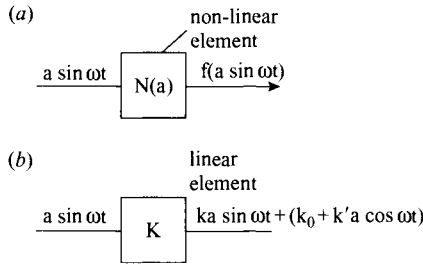

Figure 13.4 a A non-linear element
 b A linear approximation to the non-linear element in (a)

followed by a linear dynamic block of transfer function $G(s)$ (see Figure 13.3). The notation $N(a)$ emphasises that N is an amplitude-dependent gain.

As a simple illustration of the nature of $N(a)$, consider a non-linearity that on receiving a constant input a produces a constant output a^2 . We can see that the gain is

$$\frac{\text{output}}{\text{input}} = \frac{a^2}{a} = a$$

Referring to Figure 13.4, we shall assume for linearisation purposes that the output of the block in Figure 13.4a is to be approximated as closely as possible by the output of the block in Figure 13.4b.

For purposes of illustrating the approach of the describing function, we consider a non-linearity f that does not induce a non-zero mean level or cause a phase shift in response to a sinusoidal input. In such a case, the bracketed terms in the output of the block in Figure 13.4b disappear and we are left to find the k that causes best agreement between the terms $f(a \sin \omega t)$ and $ka \sin \omega t$. We define the error between these terms as $e(t)$ and then proceed to choose k to minimise the integral of the squared error.

This approach is considered more satisfying than the usual approach of simply neglecting harmonic terms in a Fourier expansion, although the two approaches lead to the same result. Hence, let

$$e(t) = f(a \sin \omega t) - ka \sin \omega t$$

We wish to minimise

$$J = \frac{1}{2\pi} \int_0^{2\pi} e(t)^2 d\omega t$$

Substitute for e and differentiate:

$$\begin{aligned}\frac{\delta J}{\delta k} &= \frac{2}{2\pi} \int_0^{2\pi} [f(a \sin \omega t) - ka \sin \omega t](-a \sin \omega t) d\omega t \\ \frac{1}{\pi} \int_0^{1\pi} ka^2 \sin^2 \omega t d\omega t &= \frac{1}{\pi} \int_0^{2\pi} a \sin \omega t f(a \sin \omega t) d\omega t \\ \frac{1}{\pi} ka^2 \left(\frac{\omega t}{2} - \frac{\sin 2\omega t}{4} \right) \Big|_0^{2\pi} &= \frac{1}{\pi} \int_0^{2\pi} a \sin \omega t f(a \sin \omega t) d\omega t \\ \frac{ka\pi}{\pi} &= ka = \frac{1}{\pi} \int_0^{2\pi} a \sin \omega t f(a \sin \omega t) d\omega t\end{aligned}$$

Finally

$$k = \frac{1}{\pi} \int_0^{2\pi} \sin \omega t f(a \sin \omega t) d\omega t$$

k can be seen to be the first term in the Fourier expansion of the output of the non-linear block of Figure 13.4a.

To see how the describing function method develops from this point onward see Grensted (1962) or Leigh (1983b).

However, it can be said that, briefly, the further development consists in deriving two loci, one for the non-linear element $N(a)$ (which, recall, has no dynamics) and one for the dynamic element $G(s)$ (which, by definition, is linear). The first locus is a function of amplitude (a) only while the second is a function of frequency (ω) only.

Especially interesting is the point or points where $G(j\omega)N(a) = -1$, since at such points there is potentially continuous oscillation around the closed loop. Such points are revealed by plotting loci of $G(j\omega)$ and $-1/N(a)$ in the same complex plane and seeking their points of intersection.

The describing function method is sufficiently developed to be able to say whether stable oscillations will occur at an intersection of loci (i.e. that the system is 'attracted' to such points) or whether it is 'repelled' from them.

13.4 Linear second-order systems in the state plane

Note that the name phase plane is used for the special case where (see below) x_2 is the derivative of x_1 .

Every linear second-order system with zero input can be expressed in the form

$$\dot{x}_1 = a_{11}x_1 + a_{12}x_2$$

$$\dot{x}_2 = a_{21}x_1 + a_{22}x_2$$

where the x_i are state variables and the a_{ij} are numerical coefficients, or $\dot{x} = Ax$ where x and A are defined by the equivalence between the two representations.

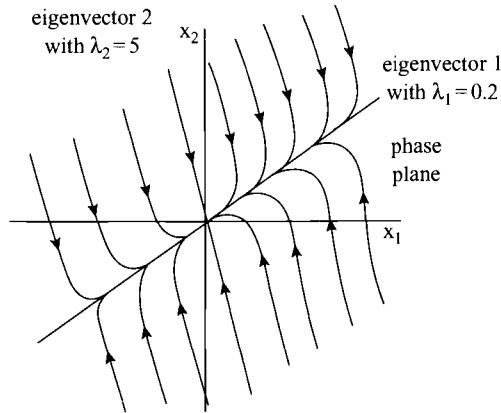

Figure 13.5 The state plane diagram for a second-order linear system with two real negative eigenvalues λ_1, λ_2

The system has one critical point, where $x = 0$. This point is always the origin $(0, 0)$.

A graph of x_2 against x_1 is called the state plane (Figure 13.5). Solutions of the equation

$$\dot{x} = Ax, \quad x(0) = x_0$$

plotted in the state plane with time as a parameter along them, are called trajectories. A state plane supplemented by representative trajectories is called a state portrait. The trajectories of a stable system reach or approach the origin of state space with increasing time. Conversely, the trajectories of an unstable system start from the origin and move outwards from it with increasing time.

If the matrix A has two real and distinct eigenvectors then these eigenvectors are important fundamental trajectories and every solution that is not an eigenvector is a weighted sum of both eigenvectors. The rate of movement of a solution along an eigenvector depends on the magnitude of the associated eigenvalue. (An eigenvalue of large magnitude implies rapid movement of the solution along the eigenvector.) All of these points are illustrated in Figure 13.5.

If the matrix A has complex eigenvalues then the solution is an expanding spiral, if the real part of the eigenvalues is positive, and a shrinking spiral if the real part of the eigenvalues is negative. All the spirals are equiangular spirals – that is, the spirals move outwards or inwards at a constant angle – measured against a rotating vector centred at the origin. These points are illustrated in Figure 13.6. Thus, the global behaviour of a linear second order system may be characterised by the eigenvalues and eigenvectors of the system matrix A .

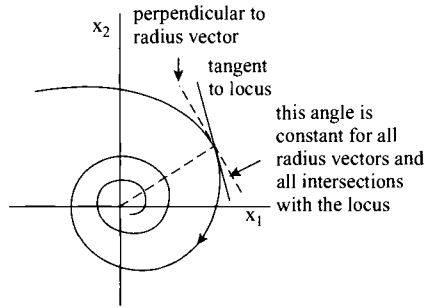

Figure 13.6 The state plane diagram for a second-order system with complex eigenvalues

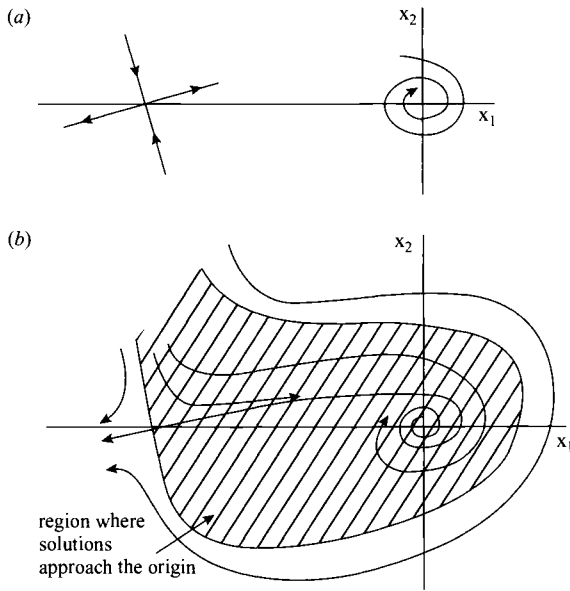

Figure 13.7 a The nature of the two critical points of the equation $\dot{x}_1 = x_2$, $\dot{x}_2 = -x_1 - x_1^2 - x_2$
 b The 'feasible' state portrait for the equation used in (a)

13.5 Non-linear second-order systems in the state plane

Consider the set of non-linear second-order systems that can be written in the form, where f_1, f_2 , are differentiable functions

$$\dot{x}_1 = f_1(x_1, x_2)$$

$$\dot{x}_2 = f_2(x_1, x_2)$$

The system has a number of critical points, given by solving the equations

$$f_1(x_1, x_2) = f_2(x_1, x_2) = 0$$

Let these points be denoted c_1, c_2, \dots, c_n .

The equations may be linearised (see Chapter 9) to produce the A matrix with typical element

$$a_{ij} = \frac{\partial f_i}{\partial x_j}$$

By substituting the coordinates of the separate critical points into the general expression for the A matrix, we produce n , generally different, A matrices, A_{c_1}, \dots, A_{c_n} .

Now in a small region around each of the critical points, the actual system behaviour is governed by the eigenvalues and eigenvectors of the appropriate A matrix. Thus the behaviour of the non-linear system in the immediate neighbourhood of critical points may easily be determined, and for many, but not all, non-linear systems, a phase portrait of the complete behaviour may easily be approximately constructed by continuing the solutions found around each critical point until they join together in a feasible way. (A few numerical solutions of the original non-linear equations can serve to check on the behaviour of any particular trajectory.) A simple example illustrates all these points.

Example: The non-linear equation is

$$\dot{x}_1 = x_2$$

$$\dot{x}_2 = -x_1 - x_1^2 - x_2$$

Critical points are $(0, 0)$ and $(-1, 0)$.

The A matrix is

$$A = \begin{pmatrix} 0 & 1 \\ -1 - 2x_1 & -1 \end{pmatrix}$$

so that

$$A_{(0,0)} = \begin{pmatrix} 0 & 1 \\ -1 & -1 \end{pmatrix}, \quad A_{(-1,0)} = \begin{pmatrix} 0 & 1 \\ 1 & -1 \end{pmatrix}$$

$A_{(0,0)}$ has complex eigenvalues with negative real part; $A_{(-1,0)}$ has real eigenvalues $+1.08$ and -2.08 with associated eigenvectors

$$\begin{pmatrix} 1 \\ 0.618 \end{pmatrix}, \quad \begin{pmatrix} 1 \\ -1.618 \end{pmatrix}$$

The local behaviour around the two critical points is therefore found to be as in Figure 13.7a and the feasible state portrait obtained by continuation and joining of trajectories is shown in Figure 13.7b.

13.6 Process non-linearity – large signal problems

Consider the operations of:

- (i) accelerating a load using an electric motor
- (ii) heating a block of metal in a furnace
- (iii) growing a population of microorganisms
- (iv) filling a vessel with liquid.

Each operation has upper limits on its achievable rate of change. In every case, the upper limits are set by rather basic aspects of the design and the upper limits can only be increased by fairly fundamental re-design of the operations.

Linear control theory (by definition) knows nothing about these limiting factors. Therefore, we may arrange for the limits to be so high that they are never encountered. The process then appears linear but possibly at a high cost in equipment. A more usual approach is to design on linear assumptions although knowing that upper excursions of signals will be sometimes affected by non-linearities. Such an approach needs to be followed by an assessment of the effect on overall performance of the non-linearities. (Such an assessment can be undertaken by either deterministic or stochastic simulations.)

13.7 Process non-linearity – small signal problems

Consider (the A level syllabus for once comes in useful) a wooden block at position x on a rough level surface. A small force f is applied where shown (Figure 13.8) and f is gradually increased until when $f > f_s$ (see Figure 13.9) the block suddenly

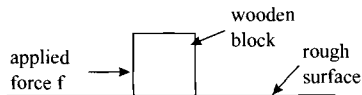

Figure 13.8 *A block of wood on a rough surface*

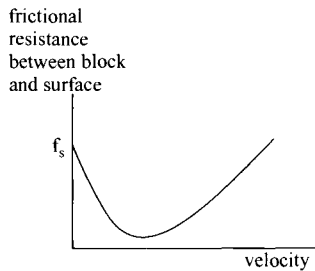

Figure 13.9 *The supposed friction characterisation between block and surface in Figure 13.9*

accelerates away. It is now clear that the block will either not move at all (if $f < f_s$) or, if $f > f_s$, it will move by some minimum amount. In accurate positioning control systems, stiction, for instance in bearings, causes precisely the same difficulty, i.e. there is a minimum unavoidable distance that a shaft must move from rest, if it is to move at all. This phenomenon is sometimes referred to as stick–slip motion.

Other types of small signal non-linearity occur in gear trains.

Considering large and small scale linearities simultaneously, it does emerge that, quite often, a high performance requirement will necessitate the purchase of equipment that is linear across a very wide signal range. Such equipment is very expensive, and, sadly, we cannot usually obtain high performance by attaching a clever control system to a cheap process that has only a narrow range of linear operation.

Chapter 14

Optimisation

14.1 Initial discussion

Optimisation is concerned with finding the best possible solution, formally referred to as the optimal solution, to a particular problem. The term optimisation is often used very loosely in general speech but in control theory it has a precise meaning: the action of finding the best possible solution as defined by an unambiguous criterion (or cost function).

Optimisation has, to some extent deservedly, acquired a reputation for being out of touch with reality. This is because the analytic techniques for optimisation are highly involved and in order to make headway many workers have resorted to drastic modification of the original problem to allow application of some particular optimisation technique; i.e. simplistic assumptions about the problem have, unsurprisingly, produced simplistic solutions. Currently, more healthy attitudes are beginning to prevail. For instance, it is becoming accepted that, for large complex problems, it may be better to encode optimality criteria in more vague but more realistic terms than parallel human evaluation criteria, than to force unwilling problems into an ill-fitting straitjacket to allow rigorous optimisation. With these reservations having been made, it is possible to turn to the ideas and techniques of optimisation theory and practice.

14.2 Optimisation – a few ideas that can form building blocks

Case 1: A mathematical function may take on a maximum value (Figure 14.1).

- (a) If we know the ‘formula’ for the function f , the maximum value can be found by the methods of elementary calculus.
- (b) If f is not known as a function, but nevertheless particular values, $f(x_1)$, $f(x_2), \dots$, can be generated for chosen values x_1, x_2, \dots , then it will clearly be possible to find the maximum value, to any desired value of accuracy, by

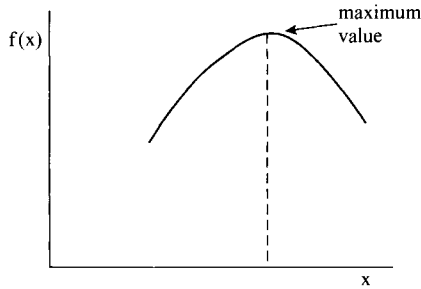

Figure 14.1 *The function takes on a maximum value where the first derivative df/dx is zero*

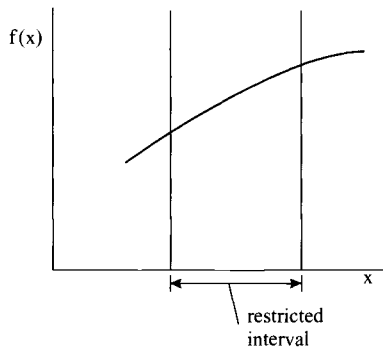

Figure 14.2 *The function takes on a maximum value at the upper end of the restricted (closed) interval*

Notice that here $df/dx \neq 0$

numerical search. The efficiency of such a numerical search will vary widely according to the approach used, but almost any conceivable approach would succeed in approaching the maximum to whatever accuracy is required.

Case 2: A mathematical function, on a restricted interval of x , will always take on a maximum value (Figure 14.2)

Strictly, any continuous function defined on a closed interval will take on maximum and minimum values on that interval.

This is Weierstrass' theorem (see Hardy, 1963).

Note in this case that, as suggested in Figure 14.2, the maximum value may be at a boundary point and that, at a boundary point, the derivative of f will not necessarily be zero and that therefore the ordinary methods of calculus will not suffice to find such maxima.

Case 3: A scalar valued function of n variables, i.e. $f : \mathbb{R}^n \rightarrow \mathbb{R}^1$ may take on a maximum value

A scalar-valued function for $n = 2$ is illustrated in Figure 14.3:

- (a) If the formula for f is known, then, again, ordinary methods of calculus will suffice to determine the maximum (i.e. $\nabla f = 0$ at the maximum).
- (b) If the formula for f is not known but nevertheless particular solutions can be generated numerically, then it is possible to imagine searching in the *parameter space* to find the particular values of x_1, x_2, \dots, x_n that maximise the function, but, whereas in case 1(b) it was clear that any algorithm, however amateur, would eventually locate the maximum value when x was a single variable, it is now by no means obvious how to search n -dimensional parameter space in a meaningful way. Even in the simple case sketched in Figure 14.3 for $n = 2$, considerable ingenuity has to be exercised in devising search algorithms.

Should the function f have a less circular shape in parameter space (i.e. as in Figure 14.4) then successful searching can be expected to be increasingly difficult.

Case 4: A scalar valued function $f : \mathbb{R}^n \rightarrow \mathbb{R}^1$ defined on a closed region of parameter space, will take on its maximum value on that region (Figure 14.5).

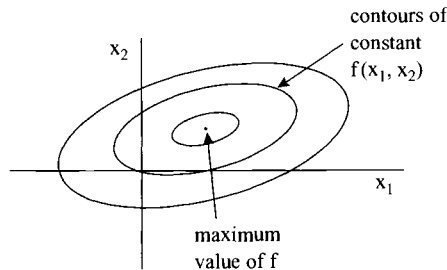

Figure 14.3 The scalar values function of two variables takes on a maximum value where $\partial f / \partial x_1, \partial f / \partial x_2$ are both simultaneously zero

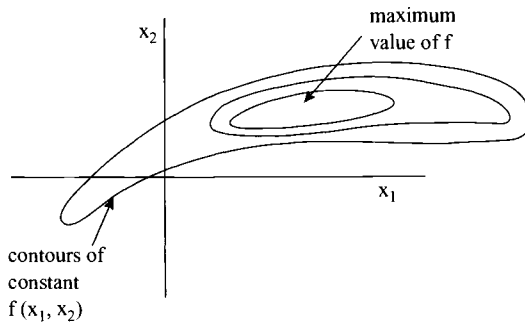

Figure 14.4 Another scalar valued function of two variables. Here the elongated contours make numerical searching for the maximum difficult

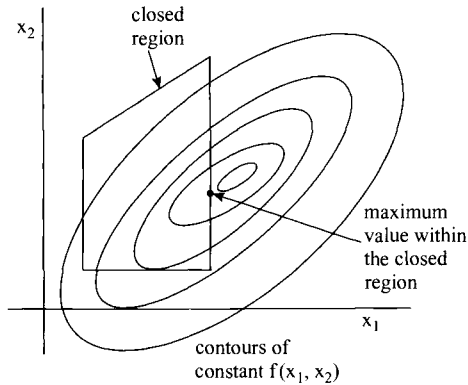

Figure 14.5 A scalar valued function of two variables will take on its maximum value within the closed region shown. If the maximum is on the boundary of the region, $\partial f / \partial x_1$ and $\partial f / \partial x_2$ will not usually be zero there

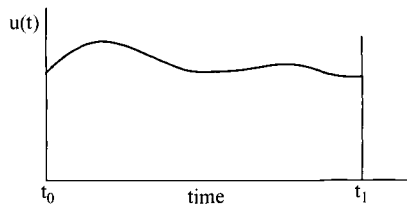

Figure 14.6 A specimen continuous function defined on $[t_0, t_f]$

Case 5: One particular function amongst a set of continuous functions on an interval may maximise a scalar valued cost function (Figure 14.6).

A specimen problem is as follows: From the set of all continuous real valued differentiable functions, $u(t) : [t_0, t_f] \rightarrow u(t) \in \mathbb{R}^1 \times t$, choose that particular function $u^*(t), t \in [t_0, t_f]$, that maximises

$$f(u(t)), f : \mathbb{R}^1 \times t \rightarrow \mathbb{R}^1$$

f is a scalar-valued criterion (cost-function) operating on the set of all real valued continuous functions $u(t)$ that are defined on the interval $[t_0, t_f]$. Even a casual inspection will show that this problem is very much more difficult than those defined earlier as cases 1 to 4.

An infinite set of candidate functions $u(t)$ exists, and although it is quite easy to envisage finding a numerical approximation to $u(t)$ using some form of computational search algorithm, the analytic method of determining $u(t)$ exactly is a classical mathematical method of great power and beauty.

This analytic method forms part of the subject usually called the calculus of variations.

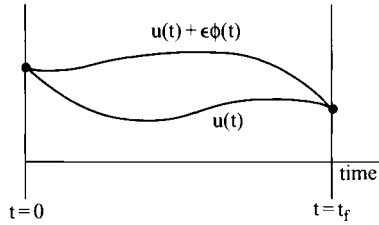

Figure 14.7 The supposed optimal curve $u(t)$ and an arbitrary variant $u(t) + \epsilon\phi(t)$

In its simplest form the method determines the curve $u(t)$ that, passing through two fixed end points, minimises a given integral.

$$J = \int_0^{t_f} f(u, \dot{u}, t) dt \quad (14.1)$$

Figure 14.7 shows the supposed optimal curve $u(t)$ and one arbitrary variant $u(t) + \epsilon\phi(t)$, $\phi(t)$ an arbitrary function and ϵ a scalar. The variant function is approximated by the first two terms of a Taylor series. Manipulation then produces the condition for optimality.

$$\int_0^{t_f} \phi \left(\frac{\partial f}{\partial u} - \frac{d}{dt} \left(\frac{\partial f}{\partial \dot{u}} \right) \right) dt = 0 \quad (14.2)$$

However, $\phi(t)$ was chosen arbitrarily; hence the optimality condition reduces to

$$\frac{\partial f}{\partial u} - \frac{d}{dt} \left(\frac{\partial f}{\partial \dot{u}} \right) = 0 \quad (14.3)$$

This is the Euler–Lagrange necessary condition for optimality of the curve.

Use of the calculus of variations to solve control problems: In optimal control problems the differential equations that model the process to be controlled must be satisfied at all times while, simultaneously, the Euler–Lagrange conditions have to be met. The extension of the calculus of variations to meet this requirement is usually performed by the use of Lagrange multipliers.

Suppose that the optimal control problem is to choose $u(t)$ on the interval $[0, t_f]$ so that the process with model

$$\left. \begin{aligned} \dot{x}_1 &= x_2 \\ \dot{x}_2 &= x_1 - u \end{aligned} \right\} \quad (14.4)$$

behaves so as to minimise

$$J = \int_0^{t_f} f(x, \dot{x}, t) \quad (14.5)$$

The Lagrange multipliers λ_1, λ_2 are introduced by enhancing the expression for J to

$$J = \int_0^{t_f} f(x, \dot{x}, t) + \lambda_1(\dot{x}_1 - x_2) + \lambda_2(\dot{x}_2 - x_1 + u) \quad (14.6)$$

Minimisation of the enhanced expression for J , still using the calculus of variations approach, will now minimise the original J while satisfying the equality constraints imposed by the process. After the Lagrange multipliers have served their purpose in this way, they are eliminated by substitution. The result obtained is an optimal control strategy, specifying a curve $u_{\text{opt}}(t)$ on the interval $[0, t_f]$ that, when input to the process (as modelled by eqn. 14.4), will result in a performance that minimises J .

Case 6: One particular function amongst a set of functions satisfying an inequality constraint may maximise a scalar valued cost function.

A specimen problem is as follows: From the set of (not necessarily continuous) functions

$$u(t) : [t_0, t_f] \rightarrow u(t) \times \mathbb{R}^1 \times t$$

that satisfy the constraint

$$\|u(t)\| \leq m \text{ [} m \text{ is a constant, for all } t \text{ in } [t_0, t_f]\text{].}$$

Let us choose that particular function $u^*(t), t \in [t_0, t_f]$ that maximises

$$f(u(t)), f : \mathbb{R}^1 \times t \rightarrow \mathbb{R}^1$$

Notice that $u(t)$ has to remain within the admissible region shown in Figure 14.8.

We observe that many practical optimisation problems arising in control applications are subject to a constraint on signal magnitude similar to (or possibly more complex than) the constraint outlined here. Very often, the optimal function $u^*(t)$ will be found to take values on the boundary of the admissible region for some or all of the time period (t_0, t_f) , as in Figure 14.9.

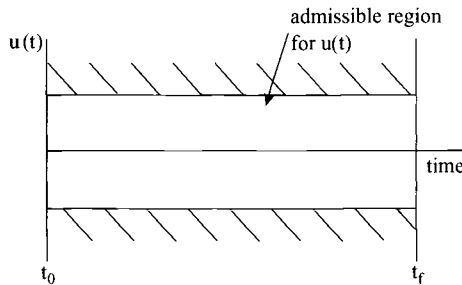

Figure 14.8 The admissible region in which $u(t)$ must remain

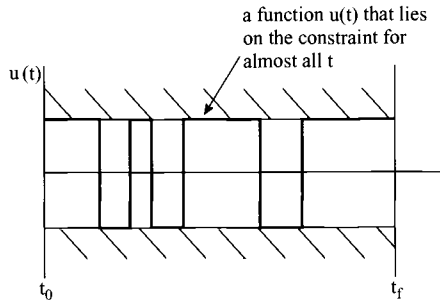

Figure 14.9 The optimal $u^*(t)$ will often take values on the boundary of the admissible region

This problem may turn out to be either more or less difficult than that of case 5. It is more difficult than case 5 in that the presence of the constraint makes it more difficult to apply methods analogous to ordinary calculus, such as those that will be described as suitable for case 5. The problem may be easier than that of case 5 in those cases where it is possible to say in advance that the optimal solution $u^*(t)$ operates along the boundaries of the region during the whole of the time period (t_0, t_f) with a finite number of switchings between these extreme values. Finding the optimal solution $u^*(t)$ then amounts to the simpler (?) problem of determining the finite set of switchover times.

The above six problems, cases 1 to 6, illustrate in a simplified way the range and nature of optimisation problems that are encountered in control theory. It must be emphasised though that the problems 1 to 6 as described concentrate only on the core features. Any realistic optimisation problem requires a quite extensive framework involving dynamic system models, a possibly complex criterion function and, where appropriate, mechanisms for taking constraints into account.

14.2.1 Discussion

We begin by listing some general points:

- (i) Even the simplest optimal control problem involves a process model and a cost function J . The process model can be considered to impose *equality constraints* on the minimisation of J .
- (ii) The choice of J is difficult in every real case – a compromise always has to be reached between relevance and mathematical tractability. Forcing a complex, often unquantifiable, problem to have a simplistic cost function is a serious but very common mishandling of optimisation.
- (iii) In most control problems, the magnitude of the controls must not exceed certain upper limits. The upper limits can be considered to be *inequality constraints* on the minimisation of J .
- (iv) Inequality constraints (see iii) prevent the calculus of variations being applied. Pontryagin's maximum principle or the method of dynamic programming then

need to be used. (The situation to be dealt with is essentially a generalisation of that where a function defined on a closed interval is to be maximised – the methods of ordinary calculus cannot be used because the maximum may not be a turning point – see Figure 14.2.)

- (v) The methods discussed above all yield open loop optimisation strategies, i.e. they specify $u_{\text{opt}}(t)$ for all t in the time interval of interest. It is usually impractical to implement open loop optimisation, except in a few special cases and the strategies need to be converted to closed loop algorithms. This conversion is always possible provided that J is a quadratic form and that the process model is linear. Under these, very restrictive, conditions the optimal feedback law is yielded by solution of a Riccati equation. Even then, the Riccati equation has time varying coefficients, making it difficult to implement, unless the optimisation horizon is infinite.
- (vi) The optimal feedback algorithm produced by solution of the Riccati equation usually requires all of the process states to be measurable on-line. If some of the process states are inaccessible, a state estimator will need to be developed to make those states available on-line.
- (vii) If a state estimator feeds an optimal feedback algorithm, the question arises: Does the combination of optimal estimator and optimal controller yield the overall optimum solution (since usually, a set of interconnected optimal sub-systems would not combine into an overall optimal system)? This problem is addressed by the separation theorem. This roughly states that, if the system is linear, the noise signals Gaussian and the cost function quadratic, then overall optimisation will be yielded by a combination of optimal state estimator and optimal feedback controller.
- (viii) The effects discussed in (i)–(vii) above add together to make realistic optimisation of a real process a very difficult task indeed. There is nevertheless a great potential for optimisation techniques to lead the way in approaches to the coordination of complex processes involving many hundreds of elements and in extracting additional productivity from systems containing complex process mechanisms (such as microorganisms).
- (ix) The literature on optimisation is enormous. Some suggestions are made in Section 19.8.

We now go on to discuss one particular optimisation problem – that of time-optimal control. This topic forms just one aspect of optimisation as discussed above and in no sense is it different or isolated. Here it has been singled out for amplification because the development is quite pleasing, leading to a geometric interpretation and a link across to operator methods of system representation.

14.3 Time-optimal control

Assume that, in the system of Figure 14.10 the shaft is at rest at position θ_0 and it is required to bring it in minimum time to a new rest position of θ_1 .

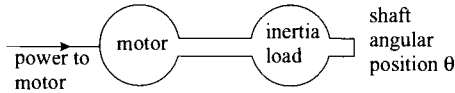

Figure 14.10 A motor driving an inertia load

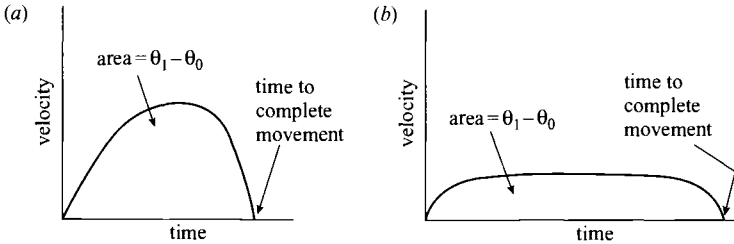

Figure 14.11 Two possible velocity profiles that each result in the movement of the shaft from position θ_0 to position θ_1

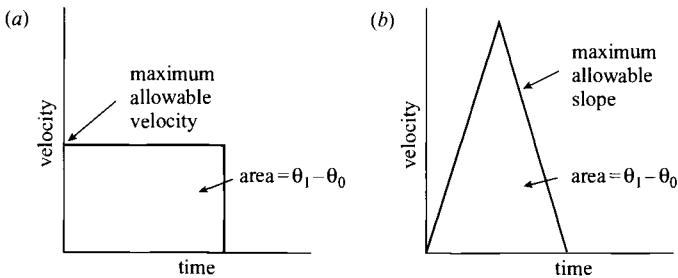

Figure 14.12 *a* Minimum time velocity profile for the case where velocity is constrained but acceleration is unconstrained
b Minimum time velocity profile for the case where acceleration is constrained but velocity is unconstrained

We can think of the problem in the following way: the quantity $(\theta_1 - \theta_0)$ is fixed and all possible solutions can be sketched as velocity/time graphs. It is clear that, to obtain a minimum time solution, we must have the steepest initial rise in velocity followed by the steepest possible fall (since, in graphs like that of Figure 14.11, we need to generate maximum area beneath the graph in the shortest time interval; i.e. the ideal velocity profile is rectangular with infinite acceleration/deceleration).

Idealised situations in which there are constraints on velocity but not on acceleration (case *a*) and vice versa (case *b*) are shown in Figure 14.12. It can be seen that the minimum time solution is only meaningful if there are constraints on velocity or acceleration – for otherwise the minimum time would approach zero as the acceleration/deceleration increased without limit (Figure 14.13).

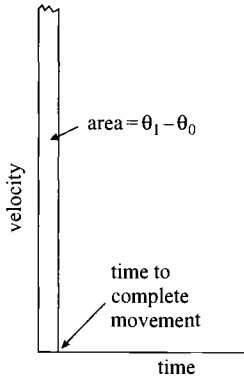

Figure 14.13 A minimum time solution with no imposed constraints tends in the limit to an infinite velocity spike

Thus we can see that the minimum time solution requires maximum acceleration followed by maximum deceleration, with the only decision being the time at which the changeover is to be made between these regimes. A control that stays on one constraint or another all the time (rigorously – almost all the time) is called a bang-bang control.

It is a result in optimal control theory that every minimum-time control problem has a bang-bang solution and it therefore follows that if the minimum-time control problem has a unique solution then that solution is a bang-bang solution.

14A Time-optimal control – a geometric view

Let the system of Figure 14.14 be at an initial state x_0 at time t_0 . Consider a time $t_1 > t_0$ and let Ω represent the set of admissible (i.e. constrained) controls defined on the closed interval (t_0, t_1) .



Figure 14.14 The system whose time-optimal control we study

Now let \mathcal{R}_1 represent the region in state space X to which the state x can be driven in time $t_1 - t_0$ by the application of all possible admissible controls in Ω_1 . Consider next a time $t_2 > t_1$, and let Ω_2 represent the set of admissible controls defined on the interval $[t_0, t_2]$. It is clear that the region \mathcal{R}_2 in X to which the state can be driven in time $t_2 - t_0$ must contain the region \mathcal{R}_1 .

Thus, considering times t_1, t_2, \dots, t_n with $t_n > \dots > t_2 > t_1$, the reachable regions in state space will have the form shown in Figure 14.15. The meaning of these regions is that any point x in region \mathcal{R}_i can be reached in time $t_i - t_0$. Under reasonable

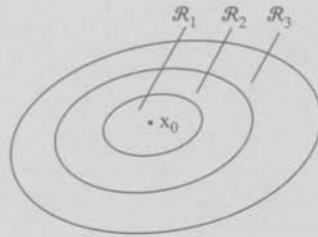

Figure 14.15 Reachable regions in state space

assumptions of smoothness the region \mathcal{R} grows smoothly with increasing time, so that, given any chosen point x_d , there exists some unique time, say t^* , for which $x_d \in \delta\mathcal{R}(t^*)$ i.e. x_d is a boundary point of the closed set $\mathcal{R}(t^*)$.

This means that:

- (i) x_d cannot be reached from x_0 by the application of admissible controls in any time $t < t^*$.
- (ii) x_d can be reached in time t^* and, because (i) applies, t^* can be seen to be the minimum time.

To summarise, a point x_d can be reached in minimum time t^* if and only if x_d belongs to the boundary $\delta\mathcal{R}(t^*)$ of the reachable set $\mathcal{R}(t^*)$ (see Figure 14.16).

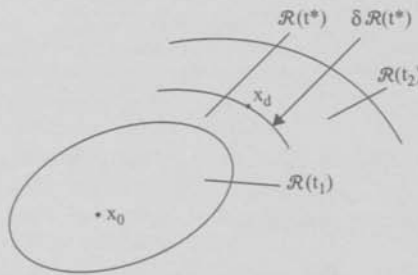

Figure 14.16 x_d belongs to the boundary of the region $\mathcal{R}(t^*)$

In Figure 14.15 x_d cannot be reached in time t_1 . x_d can be reached in time t^* and this will be the minimum time solution. x_d can be reached in time t_2 but this is not the minimum possible time. In this case, if the requirement is to reach point x_d at time t_2 , the problem is not a minimum time problem.

The shape of the reachable set \mathcal{R}

We have already observed the useful property that the set \mathcal{R} grows smoothly with time. Now we turn to examine the shape of \mathcal{R} .

If the system that we are studying is linear then it can be represented by a linear transformation, say P , operating on the initial condition x_0 and the chosen control $u(t)$

to produce a new state, i.e.

$$P : (x_0, u) \rightarrow x$$

where $x_0 \in X$, $u \in \Omega(t_0, t_f)$ for some fixed t_f ,

$$x \in X$$

And in this sense we can define $\mathcal{R}(t_f)$ as

$$\mathcal{R}(t_f) = \{x | u \in \Omega\}$$

This can be stated more simply as

$$P : \Omega \rightarrow \mathcal{R}$$

i.e. the linear transformation P maps the region Ω into the region \mathcal{R} .

We now note that convexity is invariant under linear transformation (see Hardy, 1963), and thus if the set Ω is convex (strictly convex) then \mathcal{R} will also be convex (strictly convex), provided that the system under study is linear (Figure 14.17).

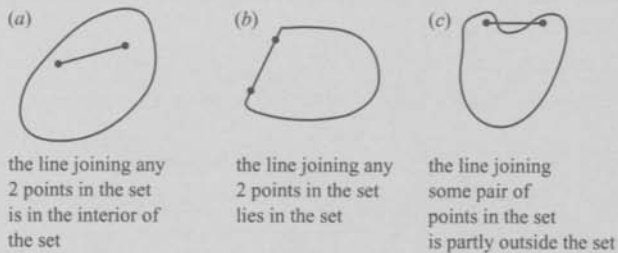

Figure 14.17 a A strictly convex set
b A convex set
c A non-convex set

Geometrically a set C is convex if the line joining any two points in C belongs wholly to C . (For strict convexity the line joining every two points must be in the interior of C .)

The shape of the set Ω of admissible controls

It is surprisingly rewarding to examine the shape of Ω as it relates to practical constrained control problems. For simplicity, we will concentrate on the case where the control input u is a vector with two elements $u_1(t), u_2(t)$.

The most common constraints encountered in practical applications are:

- (a) $u_1(t)^2 + u_2(t)^2 \leq m$ for all t , m a fixed scalar
 (b) $|u_1(t)| + |u_2(t)| \leq m$ for all t , m a fixed scalar
 (c) $\max\{|u_1(t)|, |u_2(t)|\} \leq m$ for all t , m a fixed scalar

The shape of these constrained sets for the three cases is shown in Figure 14.18. (This is the usual Euclidian norm on the space U .)

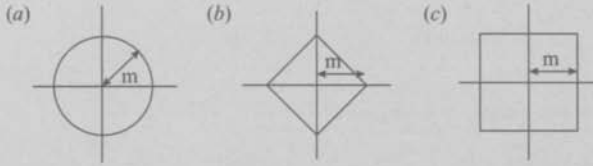

Figure 14.18 a The set Ω for the Euclidean norm
 b The set Ω for the absolute value norm
 c The set Ω for the maximum value norm

All the sets are convex but only case A has a strictly convex constraint set. (Almost all comparisons seem to end up confirming the superiority of least squares as a criterion.) Thus, for linear systems with constraints on U defined by approaches (a), (b) and (c), the set \mathcal{R} will have one of the shapes sketched above.

The significance of the shape of the set \mathcal{R}

It can also be shown that, if the set \mathcal{R} is compact, then the optimal control u to reach x_d is unique if $x_d \in \mathcal{R}(t)$ for some t . The interior mapping theorem then shows that u must attain its maximum if it is to be an optimal control. Finally, Lyapunov's theorem that the range of a vector measure is closed allows the bang-bang nature of a unique time-optimal control to be proved. Geometrically this shows that time optimality requires $x_d \in \mathcal{R}(t^*)$ and that the pre-image of x_d in Ω belongs to $\delta\Omega$ (Figure 14.19).

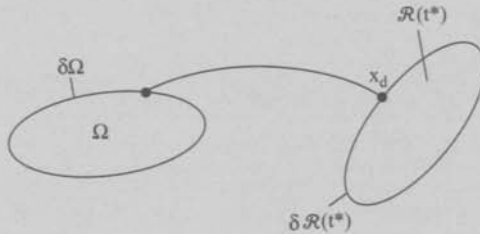

Figure 14.19 Time optimality requires that the pre-image of x_d belongs to $\delta\Omega$

14B The following geometric argument can form a basis for the development of algorithms or for the proof of the Pontryagin maximum principle

Let $x_d \in \delta\mathcal{R}(t^*)$; then there exists a hyperplane M that supports \mathcal{R} at x_d . M can be represented as the translation of the null space of some non-linear functional g on the space X i.e.

$$M = \{x | g(x) = C\} \quad C \text{ a real number}$$

can also (Riez representation theorem) be written

$$\langle x, g \rangle$$

where g is a normal to the hyperplane M

$$x_d \in \mathcal{R}(t^*) \cap M$$

and

$$\langle x_d, g \rangle = \sup_x \langle x, g \rangle$$

i.e. x_d is the farthest point from x in the set $\mathcal{R}(t^*)$ in the direction g but $x = Pu$, while if $x_d = Pu$ with $x_d \in \delta\mathcal{R}(t)$, then u is an optimal control on $[0, t^*]$. Further, if x_d is an extreme point of $\mathcal{R}(t^*)$ then u is the unique optimal control.

14C Construction of time-optimal controls

A linear dynamic system has equations

$$\dot{x}(t) = A(t)x(t) + B(t)u(t)$$

or equivalently

$$\begin{aligned} x(t) &= \Phi(t)x(t_0) + \int_{t_0}^t \Phi(t-\tau)B(\tau)u(\tau) d\tau \\ &= \Phi(t)x(t_0) + \Phi(t) \int_{t_0}^t \Phi(-\tau)B(\tau)u(\tau) d\tau \end{aligned}$$

The control problem is, given $x_d \in X$, choose $u(t) \in \Omega$ where $\Omega = \{u \mid |u(t)| \leq k\}$ such that

- (i) $x(t^*) = x_d$
- (ii) $t^* = \inf\{t \mid x(t) = x_d, t \geq t_0\}$

and define

$$e(t) = \Phi^{-1}(t)x_d - x(t_0)$$

The control objective then is to choose u such that

$$e(t^*) = \int_{t_0}^{t^*} \Phi^{-1}(\tau)B(\tau)u(\tau) d\tau \triangleq \int_{t_0}^{t^*} Q(\tau)u(\tau) d\tau$$

Assume there exists an optimal control, then, necessarily,

$$e(t^*) \in \delta\mathcal{A}(t^*) \cap M$$

where

$$\mathcal{A}(t^*) \triangleq \{r(t^*) | u \in \Omega \times [t_0, t^*]\}$$

$$M = \{x | g(x) = C, r(t) = \int_{t_0}^t Q(\tau)u(\tau)d\tau\}$$

(M is a hyperplane, g is a functional on X) for some function g and for some constant C .
Now, as we have seen, for optimality

$$\begin{aligned} \langle e(t^*), g \rangle &= \sup_u \langle r(t^*), g \rangle = \sup_u \int_{t_0}^{t^*} Q(\tau)u(\tau)g d\tau \\ &\leq \left(\int_{t_0}^{t^*} |Q(\tau)g|^q d\tau \right)^{1/q} \|u\|_p \\ &\leq k \left(\int_{t_0}^{t^*} |Q(\tau)g|^q d\tau \right)^{1/q} \end{aligned}$$

The condition for optimality is that equality should exist in the inequality chain, i.e.

$$u(\tau) = \alpha |Q(\tau)g|^{q/p} \text{sign}(Q(\tau), g)$$

where α is a constant to be determined and

$$\frac{1}{q} + \frac{1}{p} = 1$$

When U is an L^∞ space, the optimality condition reduces to

$$u(\tau) = \alpha \text{sign}(Q(\tau)g)$$

but $\|u\|_\infty = k$ for optimality; hence $\alpha = k$ to give

$$u(\tau) = k \text{sign}(Q(\tau)g)$$

t^* and g have to be computed and Kranc and Sarachik (1963) suggests appropriate methods.

Chapter 15

Distributed systems

15.1 The cosy idealisation that a system can be characterised by its behaviour at a point in space

Because of exposure to school physics and what in the UK is called applied mathematics, we are conditioned to accept without question that, for instance, an object, missile or projectile, flying through space, can be truthfully represented by a single point located at the object's centre of mass. This practice, while allowing neat examination questions, leads us into a false sense of simplistic security. For instance, as soon as a projectile is made to spin about its axis of travel (a common practice), we may be unprepared for the escalation of complexity of the problem that this simple addition to the problem causes.

Physically large systems can rarely have their characteristics approximated at a point in space without severe and often unacceptable levels of approximation. It seems to be a very interesting law of nature that increased size brings increased non-uniformity.

For instance, a small sample of the Earth's atmosphere, say a few metres square, will be approximately uniform. However, seen on a scale of hundreds of kilometres, there is extreme non-uniformity in the atmosphere, with discrete cloud forms separated by cloudless atmosphere and there are gusting winds interspersed by calm regions.

Given a system whose spatial behaviour needs to be modelled, there are three possible approaches.

- (1) To model the global behaviour by a single set of partial differential equations. The solution is then obtained by numerical methods that, depending on discretisation, approximate one partial differential equation by a set of ordinary differential equations.
- (2) To spatially discretise the physical problem into regions within which the behaviour can, with sufficient accuracy, be representable at a point. For each region, an ordinary differential equation is needed. This equation is formulated, identified and solved in the usual way for such equations.

Note, however, that, when the solution from the set of differential equations is patched together to yield the overall system solution, there may be spurious results generated at the (physically non-existent) boundaries that separate the notional regions used in the discretisation. Rosenbrock and Storey (1966) has illustrated spurious results of this sort.

- (3) 'Fourier type' modelling in which the distribution is modelled approximately but to any required degree of accuracy by a weighted sum of basis functions f_i . More specifically, if the function to be approximated on the interval $[x_0, x_1]$ is $g(x)$, then scalars α_i are chosen to minimise

$$\int_{x_0}^{x_1} \left(g(x) - \sum_{i=0}^n \alpha_i f_i(k) \right)^2 dk$$

Preferably the basis functions f_i satisfy

$$\langle f_i, f_j \rangle = 0, \quad i \neq j$$

i.e. they are orthogonal. This produces two (related) practical advantages.

- (i) The values of α_i do not depend on n ; i.e. let $\sum_{i=1}^3 \alpha_i f_i$ be the best third order fit to some given function $g(x)$; then the best fourth order fit $\sum_{i=1}^4 \alpha_i f_i$ to $g(x)$ will have unchanged α_i values for $i = 1$ to 3.
- (ii) The models will be well-behaved (as opposed to ill-conditioned) – when non-orthogonal functions are used a minor change in the curve for $g(x)$ may produce large changes in several of the α_i . These large changes, largely self-cancelling in their overall effect on function behaviour, prevent confidence being established in the numerical values of the α_i .

15.2 Alternative approaches to the modelling of distributed systems

15.2.1 *The representation of a spatial region as the summation of elemental regions*

This approach, familiar to all who have studied mathematical physics, proceeds by defining a small element of dimension $\delta x, \delta y, \delta z$ and then using equations of conservation and continuity, in conjunction with the usual methods of calculus, in which the size of the element is reduced by a limiting process to have dimension dx, dy, dz , to obtain a partial differential equation in the four variables x, y, z, t . The approach produces classical partial differential equations that have been extensively studied and that have known solutions.

Difficulties that may be encountered are:

- (i) The region under study may not divide naturally into regularly shaped elements so that approximations or awkward accommodations at the boundaries may have to be made.

- (ii) The ‘natural’ element spatial regions will often, in an industrial application, be variable shapes that may change position.
- (iii) Numerical solutions will nearly always involve a return to approximation of the region by a finite number of discrete regions, in each of which an ordinary differential equation governs the local behaviour.
- (iv) Fictitious discontinuities – present between the regions defined in (ii) above but not present in the real process – may cause spurious effects, such as travelling waves, to appear as part of the model behaviour.
- (v) For a typical industrial process whose detailed mechanisms are very complex, it will be the preferred approach to set up a simple model whose structure is determined from theoretical considerations and whose coefficients are found numerically using parameter estimation techniques on process data. Such a modelling identification procedure is difficult or impossible to carry out on most real processes, using a classical partial differential equation approach.

15.2.2 A ‘Fourier type’ approach, in which an arbitrary function f on an interval $[0, 1]$ is approximated by a summation of functions f_i

We postulate that

$$f = \sum_{i=0}^{\infty} c_i f_i \quad (15.1)$$

where f is the function to be approximated on $[0, 1]$, f_i are *basis functions*, each defined on $[0, 1]$ and the c_i are scalar valued coefficients.

Many questions immediately arise:

- (i) Under what conditions on f and f_i will the series of eqn. 15.1 be convergent?
- (ii) Define $f_n = \sum_{i=0}^n c_i f_i$. We ask: can f_n be used as a reasonable approximation to f ? Can we obtain an error estimate for $f - f_n$? Can we, operating with f_n instead of f , still work within a sound theoretical framework?
- (iii) What choice of functions f_i will form a basis for the function space?
- (iv) What choice of functions f_i will be numerically convenient and widely applicable [we have in mind *orthogonality* (is it necessary?) and behaviour at the end points 0 and 1 (we would like to avoid the enforced condition, typical of Fourier series that, necessarily, $f(0) = f(1)$].
- (v) Is it an advantage if the functions f_i are the eigenfunctions of some operator? If so, can that operator be found in a real situation?
- (vi) Do the set of functions $\{f_i, i = 1, \dots\}$ form a state in the rigorous sense?
- (vii) How may the coefficients c_i be determined from numerically logged process data?
- (viii) Can an equation $\dot{x} = Ax + Bu, x \in X, u \in U$, where X is the set of system states, U is the set of input functions and A, B are operators, be set up, identified and used analogously with the usual finite dimensional control equation of the same form?

- (ix) To what extent can the theory of operators, compact operators, closed operators, self-adjoint operators and semigroups be usefully exploited?
- (x) Can specific use be made of the projection theorem whereby a function (infinite dimensional) is approximated by its projection onto a finite dimensional subspace?

15A When can the behaviour in a region be well approximated at a point?

An interesting question is: are there fundamental guidelines to help the decision on whether a given situation can be well-approximated by the behaviour at a point? (If such guidelines can be found, they might be extremely useful in helping to choose the size and shape of regions, when spatial discretisation does turn out to be required.)

One such guideline, attributable to Roots (1969), is as follows:

Let f_{\max} represent the highest frequency of interest to which a spatial region is subject. Let l represent the largest physical distance in the region. Then provided that

$$l \ll 1/f_{\max}$$

a point representation (i.e. an ordinary differential equation model) will be justifiable. The argument appears to be that, if the physical size of the region to be modelled is much smaller than the shortest wavelength of externally applied stimuli, then the speed of propagation of effects may be regarded as instantaneous.

The relationship proposed above leaves a number of unanswered questions. For instance, in the heating of a solid object, the thermal conductivity of the material would clearly influence the uniformity of temperature that would be achieved under conditions of externally applied periodic heating stimuli, yet the proposed relation can take no account of this.

Even where a situation can be modelled exactly by unapproximated partial differential equations and the solution is obtained analytically, there is still a possible anomaly in that (for instance) the temperature distribution in a long bar is supposed to evolve as shown in Figure 15.1, i.e. the implication is that the speed of propagation is infinite (see John, 1975, pp. 175, 176).

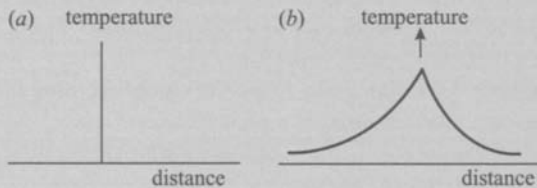

Figure 15.1 a A supposed initial temperature distribution in a long bar at $t = 0^-$
 b The form of the temperature distribution at $t = 0^+$

15B Oscillating and osculating approximation of curves

For Fourier series and for other series of orthogonal functions (Hermite, Laguerre), the approximating series approaches the required function through closer and closer oscillations. In marked contrast, the Taylor series approaches the required function by osculating at the point around which the expansion is being made. At that point, the approximation and the function approximated have exactly the same derivatives up to and including the n th derivative, for an n th order Taylor series. Figure 15.2 shows successive terms of a Taylor series being fitted to the function $\sin x$. This section follows Sommerfeld (1949) which should be consulted for further details.

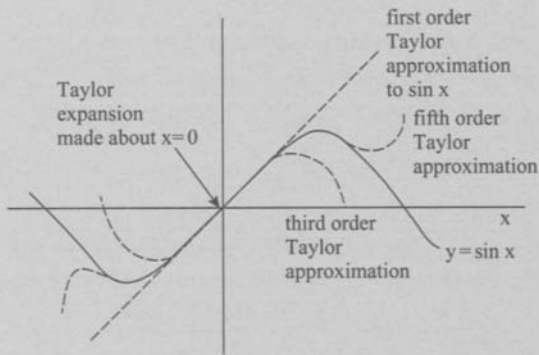

Figure 15.2 The approximation of $\sin x$ by three different orders of Taylor series expansions

Chapter 16

An introduction to robust control design using H_∞ methods

16.1 Motivation

Many promising optimisation techniques have, in the past, failed to live up to their promise, one of the most important reasons for this failure being the lack of robustness in the methods. In particular, very complex plant models were often produced and then naively assumed to be accurate representations of the real world. The inevitable mismatches between the assumed (let us say, nominal) models and the real-world processes destroyed the viability of many approaches.

H_∞ approaches, by specifically taking into account modelling uncertainty, and doing so in a worst case sense, allow complex control design problems to be solved in a theoretically rigorous way while guaranteeing robustness of the implemented solutions over a prespecified range of model incorrectness or (equivalently) of process variability.

In this chapter, we review the linear spaces that underlie much of modern operator-based control theory with particular emphasis on the theory underlying H_∞ approaches. Some of the H_∞ control design methodology is then introduced in very simple terms to establish the basic ideas. The chapter ends with an introduction to a deeply satisfying and visualisable approach: the ν gap metric method, which is firmly embedded within the H_∞ family but which is both powerful and general as well as intuitive.

16.2 Hardy spaces ($H_p, p > 0$ spaces) and their relevance to control problems

Hardy spaces (see Section 16A) are of value in control problem formulation since they provide a rigorous theoretical foundation for representing the Laplace or Fourier transform models of linear dynamical systems together with an easy link to equivalent

time domain representations. The spaces H_2 and H_∞ are the spaces of primary interest.

Linear multivariable optimisation problems with quadratic cost functions can be formulated and solved very satisfactorily in an H_2 setting in a coherent way. Optimisation in an H_2 setting can in fact be considered as a more modern replacement for linear quadratic Gaussian (LQG) approaches. Note that, by convention, the H_2 norm is applied to transfer functions/transfer matrices and the L^2 norm to time functions.

H_∞ is the Hardy space of all stable linear time-invariant continuous time system models and the H_∞ norm is a scalar measure of the upper limit of the gain of a transfer function $G(\omega)$ of a matrix of such transfer functions as frequency ω is varied.

The suffix p

The suffix p indicates that the space H_p is furnished with the p norm, so that given any element x (and such elements will normally be functions) belonging to H_p , we can measure the 'size' of x by a norm such as

$$\|x\|_p = \left(\int_0^\infty |x(t)|^p \right)^{1/p} \quad (16.1)$$

Elementary illustration – the effect of choice of p on the nature of the norm

Figure 16.1 shows a time function. We evaluate its norm using eqn. 16.1 for values of $p = 1, 2, \dots, 256$ and have plotted the results in Figure 16.2. We observe (as emphasised by the starred arrow in Figure 16.2) that as $p \rightarrow \infty$, $\|f\|_\infty \rightarrow f_{\max}$; in other words the H_∞ norm of a function simply measures the peak value of the function over a specified interval. H_∞ then is a convenient function space where the functions are normed according to their maximal values (strictly suprema).

In our example of Figure 16.1 and the plot of Figure 16.2, it was the case that

$$\| \|_p \geq \| \|_q, \quad p > q$$

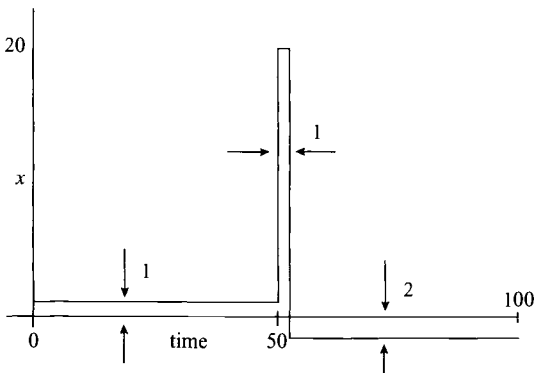

Figure 16.1 Test function to illustrate the effect of the choice of p

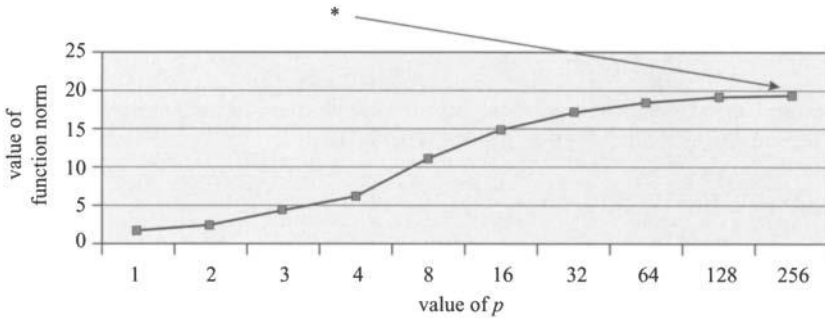

Figure 16.2 Illustrating how the norm of the function of Figure 16.1 is affected by the choice of p

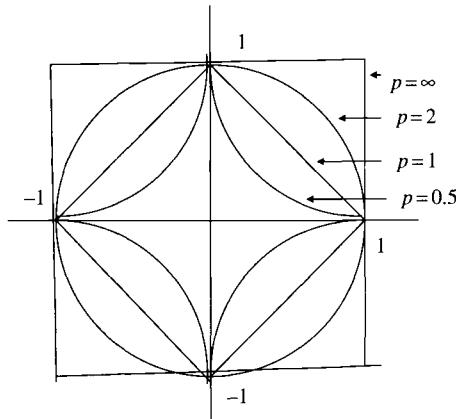

Figure 16.3 The shape of the unit ball in real 2-space for different values of p

and this is a general rule with equality holding only for functions of constant magnitude.

Non-elementary aside

Note carefully though that two functions that differ only at isolated points (i.e. they differ only on a set of measure zero) will have identical norms. This point is of considerable mathematical interest in the theory of Lebesgue integration.

In control applications, it will be rare to use values of p other than $p = 1, 2$ or ∞ . The choice of $p = 1$ leads to ‘integral of absolute error’ criteria which are sometimes used in loop tuning criteria. The choice of $p = 2$ leads to quadratic criteria which are ubiquitous since they lead to convexity and tractability, convexity being perhaps second only to linearity as a desirable quality. Note (Figure 16.3) how the unit ball satisfying

$$\|x\|_p = 1$$

looks for various values of p . From Figure 16.3 it can be seen that the unit ball has the highly desirable property of strict convexity only for the case $p = 2$.

What about H_p for $p < 1$? It will be found that when $p < 1$, H_p is no longer a normed space since the hoped-for norm fails the triangle inequality (which is one of the necessary conditions that a norm must satisfy):

$$\|x_1\| + \|x_2\| \geq \|x_1 + x_2\|$$

as the following simple example for the real plane with $p = 0.5$ demonstrates.

Let

$$x_1 = (1, 0), \quad x_2 = (0, 1) \quad \text{so that} \quad x_1 + x_2 = (1, 1)$$

Then

$$\|x_1\| = \|x_2\| = 1 \quad \text{but} \quad \|x_1 + x_2\| = \left(\sum_{i=1}^2 |x_i|^{1/2} \right)^2 = 4$$

which contravenes the triangle inequality.

16.3 A simple view of H_∞ control loop design

16.3.1 *Guaranteed stability of a feedback loop*

Zames (1976, 1981) is credited with founding H_∞ theory around the basic idea that a control loop can be represented by operators whose maximum gain across all frequencies (speaking loosely) can be represented by the H_∞ norm.

It is a key result of elementary control theory that the loop of Figure 16.4 will be input-output stable provided either:

- (1) that the gain of the GD combination is less than unity at all frequencies; or
- (2) that the phase lag of the GD combination is less than 180° at all frequencies.

But we can now express condition (1) in H_∞ language as: the closed loop of Figure 16.4 can be guaranteed I/O stable provided that $\|G(\omega)D(\omega)\|_\infty < 1$ (it being understood that for this example the H_∞ norm represents the maximum gain at any frequency).

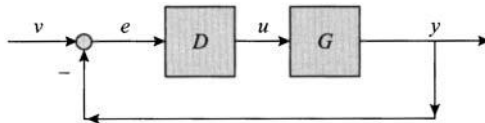

Figure 16.4 *Basic feedback control loop*

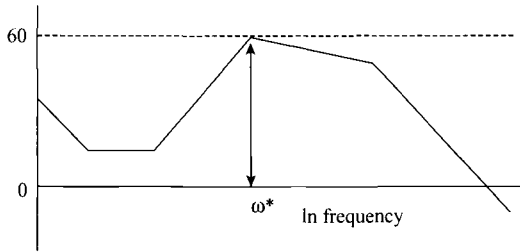

Figure 16.5 A possible Bode magnitude plot for $D(s)G(s)$

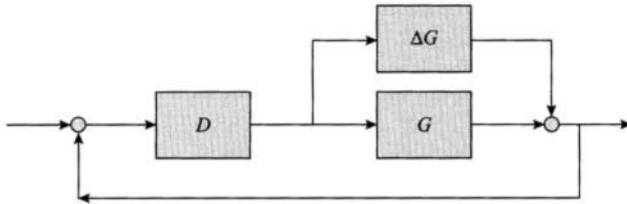

Figure 16.6 Feedback control of a process with uncertainty ΔG

Figure 16.5 shows a Bode magnitude sketch for a possible $G(s)D(s)$ combination. It has a peak value of around 60 dB at frequency ω^* . This means that

$$\frac{\|y(s)\|}{\|e(s)\|} \leq \|G(s)D(s)\|_\infty \approx 4.1$$

(converting 60 dB to a linear gain) and it can be seen that the H_∞ norm is simply the peak value of the Bode magnitude plot.

16.3.2 Robust stability of a closed loop

Consider next the closed loop of Figure 16.6 in which G represents the best available (nominal) process model and ΔG represents a deterministic model of the maximum model uncertainty. This closed loop can be guaranteed stable provided that

$$\|(G(\omega) + \Delta G(\omega))D(\omega)\|_\infty < 1$$

and this inequality is the very essence of robust control design using H_∞ methods.

Quoting Lunze (1989), it can be seen that $D(s)$ might be considered to be a stabilising common controller for the family of process models that exist within the $G + \Delta G$ envelope.

What more needs to be done or discussed before H_∞ ideas can be applied in anger? Very roughly the following:

- (i) Above, we considered only input–output stability – below we shall consider total internal stability. This will involve considering a matrix of four transfer functions even in the single-input single-output case.

The implication of (i) above is that we need a method for defining the H_∞ norm of a matrix, not necessarily square, of transfer functions. Of course, matrix transfer functions are also involved in the generalisation to multivariable problems.

- (ii) Ensuring stability by simply keeping loop gain below some peak value is only an important elemental idea. A complete design procedure will ensure good dynamic and steady state responses and rejection of disturbances despite process model uncertainties while guaranteeing stability. Such design procedures will need to trade stability margins with performance targets, using high gains in those regions of the frequency spectrum where performance is critical with carefully chosen lower gains where stability is most critical.
- (iii) As would be expected, making a deterministic model of uncertainty is bound to be difficult since uncertainty is sure to be poorly defined and difficult to pin down. Three structures are explained below to allow the modelling of different types of uncertainty.
- (iv) We need to be able to define numerical algorithms for calculation of the H_∞ norms of process model/controller combinations.

16.4 Total internal stability and design for disturbance rejection

16.4.1 *Setting the scene*

Consider a dynamic process with impulse response $g(t)$. The output of such a process in response to an input $u(t)$ is given by the usual convolution integral

$$y(t) = \int_0^t g(t - \tau)u(\tau) d\tau \quad (16.2)$$

and provided that the convolution integral is bounded on $L^2[0, \infty)$ then we can take Laplace transforms and write

$$y(s) = G(s)u(s)$$

where the transfer function $G(s)$, being bounded, belongs to H_∞ and

$$\|G\|_\infty = \sup_{\|u\|_2 < 1} \|y\|_2$$

Now consider the feedback loop of Figure 16.7 where a process of transfer function G is in a loop with a controller of transfer function D .

It is easy to show from the diagram that the following matrix relation holds

$$\begin{bmatrix} u \\ z \end{bmatrix} = \begin{bmatrix} \frac{1}{1+GD} & \frac{G}{1+GD} \\ \frac{D}{1+GD} & \frac{1}{1+GD} \end{bmatrix} \begin{bmatrix} v_2 \\ v_1 \end{bmatrix} \quad (16.3)$$

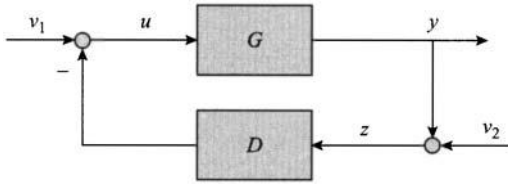

Figure 16.7 Closed loop control; G is a process and D a controller

and the feedback system is internally stable if all four of the transfer functions within the matrix of eqn. 16.3 belong to the space H_∞ . A sufficient condition for this is that

$$\|GD\|_\infty < 1 \quad (16.4)$$

16.4.2 Robust stability

Although a system such as the one in Figure 16.7 is guaranteed to be stable under the condition 16.4, there is for all practical systems a further requirement that the system should remain stable despite variations from nominal in the process G .

A feedback control system that can be guaranteed to remain stable under a specified range of process perturbations is said to possess robust stability. What we are discussing is the very common situation where the real process and its model differ by some margin, either because the process varies in quite complex ways, whereas the model is constant, or because the model is a considerable simplification of the real-world process.

Some examples: the characteristics of a strip rolling mill differ markedly according to the width, thickness and metallurgy of the product being rolled; the stabilisers of a ship interact with the effect of the rudder and vary according to ship speed; an industrial biological process varies in a complex way as the batch progresses. For all these examples, no single model can exactly allow for those variabilities. Even with a fixed known process, the modeller will almost always have to neglect effects such as high order dynamics in the interests of keeping model complexity within bounds. As the examples hopefully demonstrate, process models can only represent the real process to within some margin of error which we will name ΔG .

We assume the feedback loop for which a robust controller D is to be designed is as shown in Figure 16.7 and we also assume that the perturbation ΔG is bounded by the H_∞ norm, i.e.

$$|\Delta G(\omega)| \leq |R(\omega)| \quad (16.5)$$

for almost all ω

for some R . A key result is that the system will remain internally stable under all perturbations possible within inequality 16.5 if and only if

$$\|RD(1 + GD)^{-1}\|_\infty < 1 \quad (16.6)$$

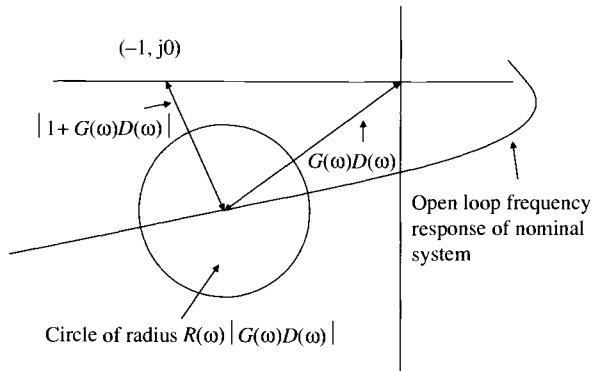

Figure 16.8 Nyquist diagram illustrating the stability inequality 16.7

To allow the concept to be appreciated in a Nyquist diagram context, we rearrange inequality 16.6 into the form

$$R(\omega)|G(\omega)D(\omega)| < |1 + G(\omega)D(\omega)| \quad (16.7)$$

The diagram, Figure 16.8, shows how the circle of model uncertainty must not enclose the $-1 + j0$ point, if stability is to be guaranteed in the closed loop system.

The robust control design procedure is then to choose the controller D to satisfy the inequality 16.6 while simultaneously meeting all performance specifications such as response rates, accuracies and disturbance rejection requirements.

It should be noted that:

- (i) the designer is given no guidance for the choice of controller D except that the frequency dependent inequality must be observed;
- (ii) the choice of a high value for R in an attempt to obtain a high degree of robustness will force down the inequality 'ceiling', resulting in a possibly unacceptable performance. Thus, not surprisingly, the overall design must balance performance and stability requirements.

16.4.3 Disturbance rejection

Disturbance rejection requirements can be injected into the H_∞ design procedure as follows. Suppose r is a disturbance signal whose effect on system output y is to be minimised and suppose also that $r(s)$ is generated by the transfer function W from any disturbance signal v_1 satisfying

$$r(s) = W(s)v_1(s) \quad \|v_1(\omega)\|_2 \leq 1 \quad (16.8)$$

Then it can easily be shown that the disturbance effect can be minimised by minimising the quantity

$$\|W(1 + GD)^{-1}\|_\infty \quad (16.9)$$

If we look at the two relations 16.6 and 16.9 relating to robust stability and noise rejection, respectively, another design compromise can be appreciated.

Setting $G = 1$ and $D = k$, i.e. an ultra-simplistic situation to emphasise this point, we have from 16.6 that

$$\frac{k}{k+1}$$

needs to be as small as possible while from 16.9 that

$$\frac{1}{k+1}$$

also needs to be as small as possible.

The first inequality is asking for k to be as small as possible whereas the second expression requires k as large as possible. The usual approach to this compromise will be to minimise

$$T = \|D(1 + GD)^{-1}\|_\infty \quad (16.10)$$

over that part of the frequency spectrum where accurate control is most critical and to minimise

$$S = \|(1 + GD)^{-1}\|_\infty \quad (16.11)$$

over that part of the frequency spectrum where disturbance rejection is most important. (S and T are often referred to as the sensitivity coefficient and complementary sensitivity coefficient, respectively.)

This leads to the concept of 'loop shaping' in which the design of the controller D can be viewed as an interactive operation to achieve the best possible performance by satisfying a number of competing frequency-dependent targets and constraints.

Ideally, since we would like

$$T(\omega) = 1 \quad S(\omega) = 0 \quad \text{for all } \omega$$

this would give perfect following and perfect noise rejection. However, it can be seen that in every case the following limits obtain

$$\lim_{\omega \rightarrow \infty} |T(\omega)| = 0$$

$$\lim_{\omega \rightarrow \infty} |S(\omega)| = 1$$

so that the design procedure consists in getting the best overall system behaviour within the above constraints. This leads to a controller synthesis methodology sometimes referred to as the mixed sensitivity approach, that results typically in magnitude versus frequency plots for S and T as shown in Figure 16.9.

Note that near-optimal designs will have sharp roll-off characteristics requiring high order controllers and an iterative interactive design approach such as used by Kwakernaak (1993) where a detailed example is worked through.

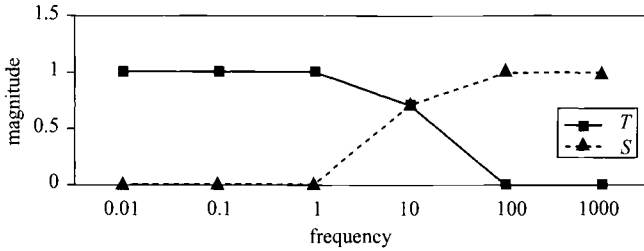

Figure 16.9 The loop shaping concept showing variation of S and T with frequency

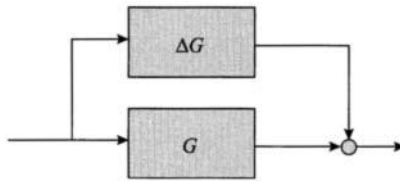

Figure 16.10 Additive uncertainty model ($G + \Delta G$)

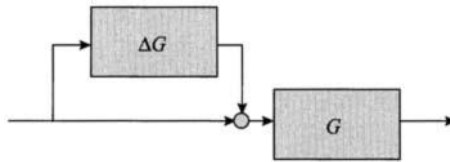

Figure 16.11 Multiplicative uncertainty model $G(1 + \Delta G)$

Because of the simple correspondences between time and frequency domain properties of H_∞ spaces, design approaches can be expressed and utilised equally well in the time domain using state space approaches.

16.5 Specification of the ΔG envelope

Clearly it will be difficult to specify ΔG in a standard generic form that fits a wide range of applications while remaining mathematically tractable. Considerable effort has been expended on the topic of ‘identification for robust control’ (see Chen, 2000) since the overall credibility of H_∞ design approaches depends on realistic specification of the ΔG envelope.

In the general case where G will be a matrix transfer function, it will be appreciated that the envelope of allowable uncertainty that we are calling ΔG must be able to represent the effects of, for example, individual parameters varying significantly, stochastic variation across a range of parameters and neglected dynamics that are in the real process but not in the model. Having noted the difficulty of specifying the ΔG envelope in a case-independent way we show in Figures 16.10–16.12 the three

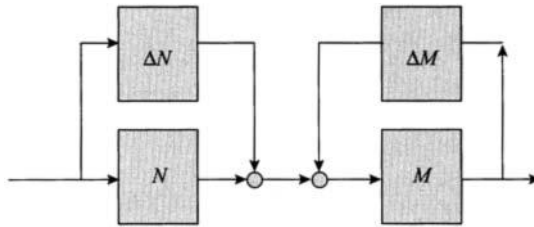

Figure 16.12 Coprime factorisation uncertainty model. Factorising G to form $G = M^{-1}N$ and then perturbing M, N , separately, leads to the diagram shown

most common configurations for representing ΔG . The so-called coprime factorisation model (16.12) allows for the most general modelling of mismatch including the mismatch of neglected dynamics.

16.6 Deriving H_∞ norms from dynamic process models

16.6.1 Singular values and eigenvalues

Singular values and eigenvalues play a central role. Let A be any $m \times n$ matrix. Then singular value decomposition consists in finding orthonormal matrices U, V , i.e. satisfying

$$UU^T = VV^T = I$$

and

$$A = USV^T$$

where

$$S = \begin{bmatrix} \Sigma & 0 \\ 0 & 0 \end{bmatrix} \quad (16.12)$$

where Σ is a diagonal matrix of non-zero singular values σ_i of A , usually arranged in descending order such that

$$\sigma_1 \geq \sigma_2 \geq \dots \geq \sigma_r > 0$$

Note that the range space $R(A)$ of A is generated by the set

$$\{u_i\}, \quad i \in [1, r]$$

and the null space $N(A)$ of A by the set

$$\{u_i\}, \quad i \in [r + 1, n]$$

By convention, the largest singular value is denoted

$$\bar{\sigma}$$

and the smallest singular value by

$$\sigma$$

Consider the equation

$$y = Ax$$

Then it can be seen that

$$\sigma(A) \leq \frac{|y|}{|x|} \leq \bar{\sigma}(A)$$

and therefore the operator norm is

$$\|A\| = \bar{\sigma}(A) \tag{16.13}$$

(since the operator norm is defined as

$$\|A\| = \sup_{x \neq 0} \frac{\|Ax\|_2}{\|x\|_2} \tag{16.14}$$

and if $G(s)$ is a matrix transfer function such as

$$G(s) = \begin{bmatrix} G_{11}(s) & G_{12}(s) & \dots & G_{1r}(s) \\ \dots & & & \dots \\ \dots & & & \dots \\ G_{m1}(s) & \dots & \dots & G_{mr}(s) \end{bmatrix} \tag{16.15}$$

then an important result is that

$$\|G(j\omega)\|_\infty = \sup_\omega \bar{\sigma}(G) \tag{16.16}$$

16.6.2 Eigenvalues of a rectangular matrix A

Consider the equation

$$y = Ax$$

$$\|x\|_2 = \left(\sum |x_i|^2 \right)^{1/2} = \sqrt{x^* x}$$

where * indicates adjoint. (The adjoint of a vector or matrix is obtained by first transposing and then complex conjugating the elements.) Then

$$|y|^2 = |Ax|^2 = x^* A^* Ax$$

Note that a complex valued matrix A is self-adjoint (Hermitian) if $A^* = A$. Self-adjoint matrices are always diagonalisable and always have real eigenvalues. Note also that $(AB)^* = B^*A^*$.

The matrix A^*A is always square and self-adjoint (Hermitian) since

$$(A^*A)^* = A^*A^{**}A^*A$$

It therefore has real non-negative eigenvalues λ_i . Let these be ordered such that

$$\lambda_1 \geq \lambda_2 \geq \dots \geq 0$$

16.6.3 Singular values and their relation to eigenvalues

The singular values of a matrix A are defined alternatively as

$$\sigma_i = \sqrt{\lambda_i} \tag{16.17}$$

where λ_i are the eigenvalues of A^*A and

$$\bar{\sigma}(A) = \bar{\lambda}^{1/2}(A^*A) \tag{16.18}$$

where $\bar{\lambda}$ is the largest eigenvalue of A .

16.6.4 Relations between frequency and time domains

Of course the domains are linked through the convolution integral

$$y(t) = \int_0^t g(t - \tau)u(\tau) d\tau \tag{16.19}$$

where $g(t)$ is an impulse response (and provided that the convolution integral is bounded on $L_2[0, \infty)$, then we can take Laplace transforms and write

$$y(s) = G(s)u(s) \tag{16.20}$$

where the transfer function $G(s)$ being bounded belongs to H_∞ and

$$\|G\|_\infty = \sup_{\|u\|_2 < 1} \|y\|_2$$

$$\|G\|_\infty = \sup_{\omega \in [0, 2\pi]} (G(\omega)) \tag{16.21}$$

and in the time domain

$$\|G\|_\infty = \sup_{u \neq 0} \frac{\|y(t)\|_2}{\|u(t)\|_2} \tag{16.22}$$

and the H_∞ norm on G can be seen to be the usual norm on a mapping from the space of time functions U to the space of time functions Y . (Note that

$$\|y(t)\|_2 = \sqrt{\int_0^\infty y(t)^T y(t) dt}$$

Finally we note from Parseval's theorem that

$$\|\hat{x}\|_2 = \|x\|_2 \quad (16.23)$$

where x is a time signal in

$$L^2[-\infty, \infty]$$

and

$$\hat{x} \text{ in } L^2[-j\omega, j\omega]$$

is the Fourier or Laplace transform of x .

16.7 A promising visualisable design tool that works within the H_∞ frame: the ν gap metric

16.7.1 Introduction

The following interesting quotation is from Vinnicombe (2001), as are all the results and examples in this section:

One of the key aims of using feedback is to minimise the effects of lack of knowledge about the system which is to be controlled. Yet, one clearly needs to know something about that system in order to be able to design an effective feedback compensator for it. So, how accurate need a model be, and in what sense should it be accurate? Or, in other words, 'how much do we need to know about a system in order to design a feedback compensator that leaves the closed loop behaviour insensitive to that which we don't know?'

Let G_1 be the transfer function of a process that is to be controlled and let G_2, G_3 be perturbed versions of G_1 . G_1, G_2, G_3 may be regarded as three possible models of the same process for which a single (robust) controller is sought. The 'distance' between any two processes G_i, G_j in terms of similarity of behaviour when connected into a closed loop can be quantified by the ν gap metric which has the property

$$\delta_\nu(G_1, G_2) = \delta_\nu(G_2, G_1) \in [0, 1] \quad (16.24)$$

An algorithm for the calculation of δ_ν will be given after an illustrative example.

16.7.2 Simple illustration of the use of the ν gap metric

The following very simple example shows the value of the ν gap metric as a guidepost in deciding how to group processes that may have widely differing open loop responses into clusters that can be successfully controlled by the same controller D . The value of such insight can hardly be overstated.

Define three process models

$$G_1 = \frac{100}{2s + 1}$$

$$G_2 = \frac{100}{2s - 1}$$

$$G_3 = \frac{100}{(s + 1)^2}$$

Then $\delta_\nu(G_1, G_2) = 0.02$, whereas $\delta_\nu(G_1, G_3) = 0.899$, showing that the two models G_1, G_3 are very different from the point of view of the ν gap metric, which (recall) has a maximum value of unity.

One of the conclusions of this worked example is that the two processes G_1, G_2 , one stable and the other unstable, would be expected to have very similar closed loop behaviours when controlled by the same controller D .

Fixing the controller $D = -1$ for both cases, we calculate the closed loop transfer functions for the two cases to be:

$$\frac{G_1}{1 - G_1 D} = \frac{100}{2s + 1 + 100} = \frac{100}{2s + 101}$$

$$\frac{G_2}{1 - G_2 D} = \frac{100}{2s - 1 + 100} = \frac{100}{2s + 99}$$

confirming the utility of the gap metric in clustering open loop models according to their predicted closed loop behaviour.

16.7.3 More about the two metrics δ_ν and $b_{G,D}$

Provided that certain continuity conditions relating to right half-plane poles are satisfied (see Vinnicombe, 2001, for details), the following algorithm allows δ_ν to be calculated:

$$\sqrt{1 - \delta_\nu(G_1, G_2)^2} = \left(\frac{\begin{array}{cc} G_2 G_1^* & G_2 \\ 1 + G_1^* G_2 & 1 + G_1^* G_2 \end{array}}{\begin{array}{cc} G_1^* & 1 \\ 1 + G_1^* G_2 & 1 + G_1^* G_2 \end{array}} \right) \quad (16.25)$$

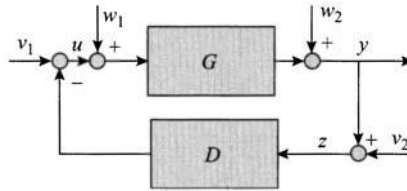

Figure 16.13 Configuration for discussion of the measure $b_{G,D}$

The v gap metric approach also makes extensive use of another metric, the quantity b , defined by the relation

$$b_{G,D} = \begin{cases} \left\| \begin{bmatrix} G \\ I \end{bmatrix} (I - GD)^{-1} \begin{bmatrix} -D & I \end{bmatrix} \right\|_{\infty}^{-1} & \text{if } [G, D] \text{ is stable} \\ 0, & \text{otherwise} \end{cases} \quad (16.26)$$

From Figure 16.13 it can be seen that

$$\begin{pmatrix} y \\ u \end{pmatrix} = \begin{pmatrix} \frac{G}{1 - GD} & \frac{-GD}{1 - GD} \\ 1 & -D \\ \frac{1}{1 - GD} & \frac{-D}{1 - GD} \end{pmatrix} \begin{pmatrix} v_1 \\ v_2 \end{pmatrix} \quad (16.27)$$

(where for simplicity the weights w_i have been set to zero) and the expression inside the norm sign of eqn. 16.26 is the transfer function between

$$\begin{bmatrix} v_1 \\ v_2 \end{bmatrix} \text{ and } \begin{bmatrix} u \\ y \end{bmatrix}$$

Properties of $b_{G,D}$

- $b_{G,D} \in [0, 1]$ for any G, D .
- $b_{G,D}$ is a bound for all eight transfer functions linking inputs and outputs in the closed loop.
- $b_{G,D} = b_{D,G}$.
- Let ρ be the ‘distance’ between the two frequency responses $G(\omega), D(\omega)$. Then $b_{G,D} = \inf_{\omega} \rho(G(\omega), D(\omega))$, that is, $b_{G,D}$ is the smallest distance between the frequency responses of G and D .
- We also define $b_{\text{opt}}(G) = \sup_D b_{G,D}$, i.e. this is the largest value over all possible linear controllers D .

We want b to be as large as possible since then the quantity in the norm signs of eqn. 16.25 will be as small as possible. (This will correspond to minimising S and making $T = 1$ as we discussed before in Section 16.4.)

Theorem 16.1 Given a nominal plant G_1 , a controller D and a scalar β , then (G_1, D) is stable for all plants G_2 satisfying $\delta_v(G_1, G_2) \leq \beta$ if $b_{G_1,D} > \beta$.

Theorem 16.2 Given a nominal plant G_1 , a perturbed plant G_2 and a scalar β satisfying $\beta < \beta_{\text{opt}}(G_1)$ then (G_2, D) is stable for all controllers D satisfying $b_{G_1 D} > \beta$ if $\delta_v(G_1, G_2) < \beta$.

16.7.4 The insight provided by the v gap metric

The three quantities

$$b_{G_1 D}, b_{G_2 D}, \delta_v(G_1, G_2)$$

obey the following triangle inequality, visualisable in Figure 16.14:

$$b_{G_1 D} \geq b_{G_2 D} - \delta_v(G_1, G_2) \tag{16.28}$$

The distance between models G_1, G_2 may be considered to be model uncertainty, and the idea can be taken further as follows.

Consider the set of process models

$$\{G: \delta_v(G_1, G) \leq \beta\} \tag{16.29}$$

Then any controller D satisfying

$$b_{G_1 D} > \beta$$

will stabilise every process model in the set specified in eqn. 16.29. Figure 16.15 is a visualisation aid to accompany the above result.

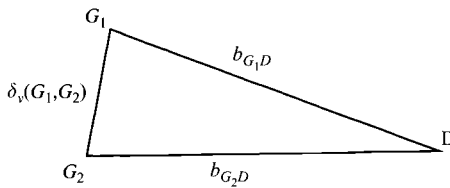

Figure 16.14 Visualisation of the triangle inequality

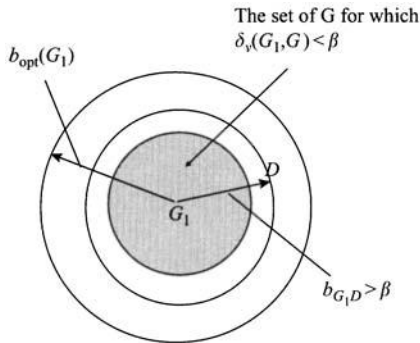

Figure 16.15 The controller D can stabilise every process whose model is within the inner circle

16.7.5 *Taking into account the weights shown in Figure 16.13 to allow loop shaping*

In order to reflect the performance and robustness requirements of individual designs it will be necessary to include the weights $w_i(\omega)$ shown in Figure 16.13 into the definitions to achieve loop shaping. The general idea as outlined above will be unchanged but robustness will now need to be achieved while observing loop shaping constraints that have been built into the definitions.

16.7.6 *A discussion on the two metrics δ_ν and $b_{G,D}$*

Consider two quite different industrial design scenarios:

- (i) A cruise (automatic highway speed) control is being designed that must operate on a range of trucks having different engine/transmission types. Further, each truck, in service, will operate with a range of loads over a range of highway gradients.
- (ii) A steel strip rolling mill rolls a variety of products of differing widths, thickness, temperatures and hardnesses and is to have an automatic thickness control system designed.

In both cases, it would be quite routine to design the necessary controllers using well established classical techniques were it not for the large envelope of variability in the processes to be controlled. Almost every real industrial control task has either feature (i) – a single controller is to be designed to be fitted into a wide range of products and the hope is to avoid having to customise for each application – or feature (ii) where a single process has to produce a range of products whose varying characteristics form part of the control loop.

Suppose we were able to write a small number of transfer functions G_i that together spanned the required range of process variability. The G_i might vary in terms of parametric uncertainty or in terms of structure, or both. The ν gap metric would then allow us to plot the G_i in a visualisable plane mutually separated by distances

$$\delta_\nu(G_i, G_j)$$

as indicated in Figure 16.16.

Now encircle each of the G_i in Figure 16.16 by its own circle of radius $\beta_{\text{opt}}(G_i)$ as shown in Figure 16.17.

Each circle defines the region within which stabilising controllers D_i , for that particular G_i certainly exist. In the illustration given here, a range of constant controllers exists, in the region marked by the starred arrow in Figure 16.17, any one of which can stabilise any of the processes G_2, G_3, G_4 . The diagram indicates that a stabilising controller may not exist for the process G_1 .

The ν gap metric approach is most valuable for multivariable problems where intuitive classical loop shaping cannot be applied.

Vinnicombe (2001) is the source for all the material of this section and that reference contains a systematic and detailed exposition with examples and proofs.

Let G_1, \dots, G_4 be any set of process transfer functions. Then in an appropriate space they can all be displayed separated by their distances apart according to the v gap metric as shown:

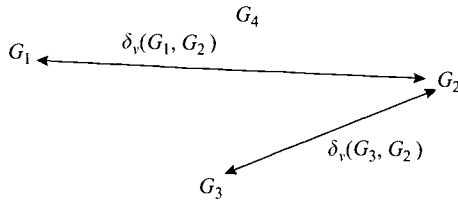

Processes that are close in the diagram have similar closed loop responses, although they may have very different open loop responses

Figure 16.16 How the v gap metric and the b metric combine to provide powerful quantitative insight into stabilisability and robust control

The same processes, as in Fig. 16.16, now surrounded by their circles of radius $b_{opt}(G)$.

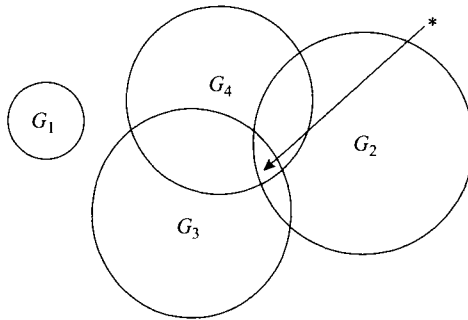

Figure 16.17 How the v gap metric and the b metric combine to provide powerful quantitative insight into stabilisability and robust control

16.8 Adaptivity versus robustness

A robust controller is designed to control all processes having transfer functions, loosely speaking in the range $G + \Delta G$ where ΔG represents either

- (i) a bound on modelling uncertainty, or
- (ii) an estimate of the envelope of variability for the process over different expected situations.

Where ΔG , the region of process uncertainty, is large, the performance with any fixed robust controller may be inadequate for the application. In such a case, there may

be an advantage in introducing a degree of adaptivity into the controller, allowing it, so far as possible, to track the parameters of the actual process, instead of having to allow *a priori* for the possible spread of parameters.

The decision on whether to use robust design, adaptive control or a combination of the two will need to be made on a case-by-case basis, taking into the rate of change of process characteristics and the identifiability of the process parameters.

16A A hierarchy of spaces

Figure 16.18 shows how spaces are axiomatically defined with increasing structure as one passes down the diagram starting from topological spaces with few properties except connectedness, down through metric and normed spaces possessing measures of size and distance, to the Lebesgue and Hardy spaces that give theoretical underpinning to much of control theory.

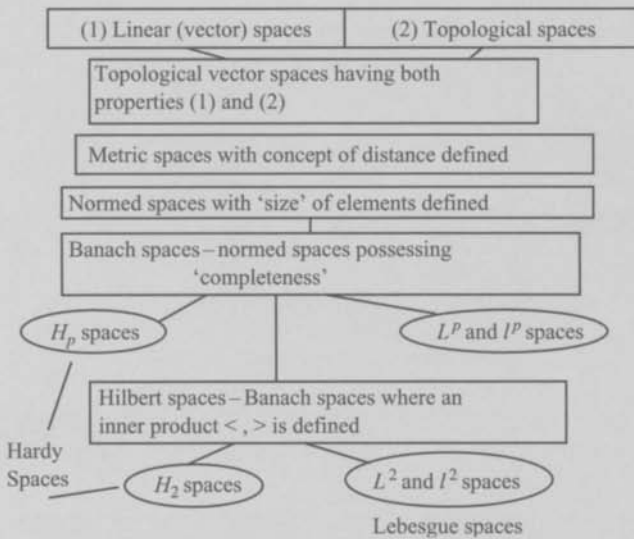

Figure 16.18 A hierarchy of spaces showing increasing structure as the diagram progresses downwards

Lebesgue spaces $L^p[a, b]$

Lebesgue spaces $L^p[a, b]$ (named after Henri Lebesgue (1875–1941) who developed the modern rigorous theory of integration based on a foundation of his pioneering work on measure theory) are defined as spaces of functions f where the integral exists.

$$\left(\int_a^b |f(t)|^p \right)^{1/p}, \quad p \in [1, \infty)$$

The L^p spaces are linear (vector) spaces since the sum of two integrable functions is again integrable and the scalar multiple of an integrable function is again integrable. Note also that in L^p spaces we are always dealing with equivalence classes of function rather than with individual functions. This arises because functions that differ only at isolated points (more formally, functions that differ only on a set of measure zero) are identical from an L^p point of view).

Sequence spaces l^p

Let X be a set of sequences $\{x_i\}$ of real numbers. Let every such sequence satisfy

$$\left(\sum_{i=1}^{\infty} |x_i|^p \right)^{1/p} \leq m < \infty$$

where p is a real number

$$p \in [1, \infty)$$

Then m is a norm for X and X is called an l^p space. When $p = \infty$, we define

$$\|x\|_\infty = \sup_i |x_i|$$

Inclusion relations between spaces

Let P be the space of all polynomials, C^n be the space of all n times differentiable functions, C be the space of all continuous functions and let $1 < p < q < \infty$. Then, assuming that all the functions are defined on the same finite interval

$$P \subset C^\infty \subset C^1 \subset C \subset L^\infty \subset L^q \subset L^p \subset L^1$$

Let \mathcal{C} be the set of all convergent sequences, \mathcal{C}_0 be the set of all sequences convergent to zero, and let $1 < p < q < \infty$. Then the following inclusion relations apply amongst the sequence spaces:

$$l^1 \subset l^p \subset l^q \subset \mathcal{C}_0 \subset \mathcal{C} \subset l^\infty$$

The norm of a linear mapping T

The norm of a linear mapping T is usually defined in terms of a ratio of L^2 norms on the domain and range spaces.

Hardy spaces

Hardy spaces have become increasingly important in control theory since about 1985. The foundations of these spaces and their naming in 1923 in honour of the Cambridge mathematician G. H. Hardy (1877–1947) is due to the Hungarian analyst F. Riesz (1880–1956), who was one of the founders of functional analysis. Hardy spaces are important in harmonic analysis, power series, operator theory and random processes as well as in control theory.

The space H_∞

H_∞ is a member of the family of **Hardy spaces** (H_p , $p > 0$). It is the Banach space of all complex-valued functions of a complex variable that are analytic and bounded in the right half plane where

$$\operatorname{Re} s \geq 0$$

Such functions have the norm

$$\|f\|_\infty = \sup_{\operatorname{Re} s > 0} |f(s)|$$

and by Fatou's theorem, which says that these functions can be defined by their boundary values,

$$\|f\|_\infty = \operatorname{ess\,sup}_\omega |f(j\omega)|$$

See Duren (2000) for the underpinning theory of H_p spaces.

A note on notation

There appears to be a rough consensus that Lebesgue spaces are denoted L^p spaces (p being superscript) whereas Hardy spaces are denoted H_p (p being subscript). I have followed this convention.

16.9 References on H_p spaces and on H_∞ control

- CHEN, B. M.: 'Robust, and H_∞ control' (Springer Series in Communications and Control Engineering, London, New York, 2000)
- CHEN, J. and GU, G.: 'Control-oriented system identification: an H_∞ approach' (John Wiley, New York, 2000) (*Describes methodologies for obtaining the types of models of processes and their uncertainties that are needed by H_∞ design methods.*)
- DULLERUD, G. E. and PAGANINI, F. G.: 'A course in robust control theory: a convex approach' (Springer, New York, 2000)
- DUREN, P. L.: 'Theory of H_p spaces' (Dover Publications, Mineola, New York, 2000)
- GRIMBLE, M. J.: 'Industrial control systems design' (John Wiley, Chichester, 2001) (*A monumental piece of work based on H_2 and H_∞ methods and their application to industrial problems.*)
- KWAKERNAAK, H.: 'Robust control and H-optimisation – tutorial paper', *Automatica*, 1993, **29**(2), pp. 255–273
- LUNZE, J.: 'Robust multivariable feedback control' (Prentice Hall, New York, 1989)
- MORARI, M. and ZAFIRIOU, E.: 'Robust process control' (Prentice Hall, Englewood Cliffs, NJ, 1989)

- VINNICOMBE, G.: 'Uncertainty and feedback: H_∞ loop-shaping and the v-gap metric' (Imperial College Press, London, 2000)
- ZAMES, G.: 'Feedback and complexity, Special plenary lecture addendum'. Proceedings of IEEE Conference on *Decision and Control*, 1976, Addenda, pp. 1–2. (*Zames is usually credited with creating the initial concept from which H_∞ theory developed.*)
- ZAMES, G.: 'Feedback and optimal sensitivity: model reference transformations, multiplicative semi-norms, and approximate inverses', *IEEE Trans. Auto. Control*, 1981, **AC-26**, pp. 301–320
- ZHOU, K., DOYLE, J. C. and GLOVER, K.: 'Robust and optimal control' (Prentice Hall, Upper Saddle River, NJ, 1996) (*A book by some of the researchers who contributed to the creation and development of the topic.*)

Chapter 17

Neural networks, fuzzy logic, genetic algorithms, learning systems, intelligent systems

17.1 Introduction

This chapter describes a selection of what are sometimes referred to as AI techniques (in fact these methods are, in general, empirically/numerically based rather than being analytically/theoretically based like the bulk of conventional control theory).

Neural networks are sets of interconnected artificial neurons that, very simplistically, imitate some of the logical functioning of the brain. After training, they can represent any algebraic non-linearity. They have to be trained by being presented with sufficient examples of the input–output behaviour that is desired, so to a large extent they can only represent existing data-generating phenomena by empirical equivalents.

Fuzzy logic emulates the reliable but approximate reasoning of humans, who, it is said, distinguish only six or seven different levels of any variable during decision making. Fuzzy logic algorithms can represent this style of reasoning by easily understood curves that are ideal for implementing those many control systems that are based on ‘having a feel’ or on ‘rules of thumb’ rather than on equations.

Genetic algorithms and genetic programming are powerful evolutionary search methods that can search for structures as well as numerical parameters. These qualities allow the methods to synthesise solutions to a wide variety of problems. The approaches rely heavily on imitating the methods of animal/human reproduction followed by natural selection. Because the methods can search amongst many alternative structures, they can also be regarded as design or synthesis methods.

Learning systems aim to emulate the human learning-by-experience mechanism so that a system can potentially learn to perform a task with increasing efficiency over time using an iterative algorithm.

Intelligent machines and machine intelligence offer future prospects for creating systems with ever increasing autonomy and reasoning ability.

17.2 Artificial neural networks (ANN)

17.2.1 Motivation

From a control point of view a neural network can be regarded principally as a non-linear input–output black box that can emulate a process, a controller, a state estimator or a classifier (Figures 17.1 and 17.2). Neural nets contain coefficients called ‘weights’ (Figure 17.3). They need to be taught by being presented with numerical examples (that represent the desired behaviour) while the weights are modified by a training algorithm until the neural net performs as closely to the examples as possible.

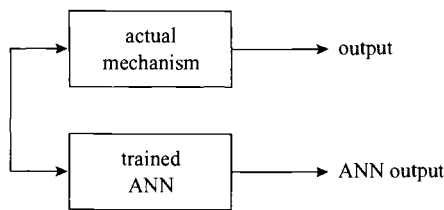

Figure 17.1 Basic abilities of neural nets: after being trained with a sufficient number of accurate examples, they can emulate any non-dynamic non-linear mechanism

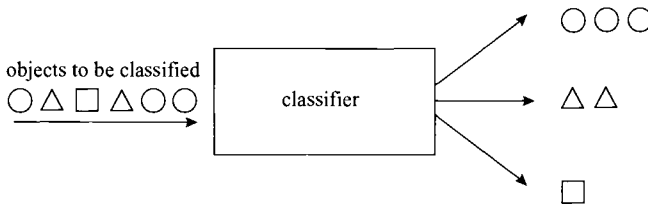
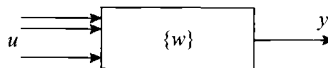

Figure 17.2 Basic abilities of neural nets: after being trained with a sufficient number of accurate examples, they can act as classifiers



A neural network has a memory $\{w\}$ of ‘weights’ that are learned during training.

A neural network can be a process model, an inverse model, a controller, an estimator, a classifier or a filter.

Figure 17.3 Basic abilities of neural nets: the choice of weights w determines the function that is emulated

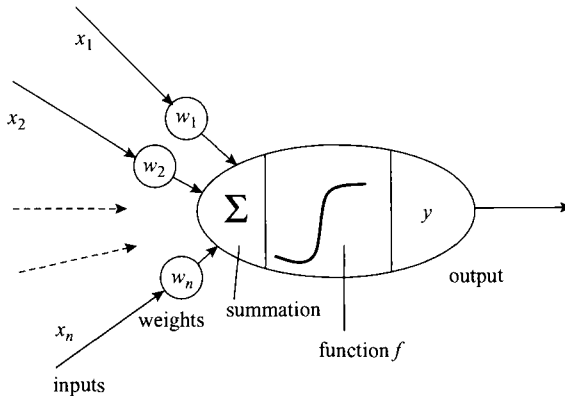

Figure 17.4 Architecture of a typical neuron

17.2.2 A basic building block – the neuron

A neural network is made by interconnecting a number of neurons (referred to equivalently as perceptrons, nodes or processing elements). Figure 17.4 shows a single neuron. It receives n inputs x_i , each x input being multiplied by a weight w_i . The neuron sums the weighted inputs, adds in a bias term b and then processes the sum through a function f to produce a scalar output y , given by the equation

$$y = f \left(\sum_{i=1}^n x_i w_i + b \right) \quad (17.1)$$

The function f is the choice of the user but the characteristics of the sigmoid function

$$f(x) = \frac{1}{1 + e^{-x}} \quad (17.2)$$

make it the most widely applied for general emulation purposes.

Training of the neuron implies fixing numerical values for the weights w and the bias b so that the neuron behaves in a desired way.

17.2.3 Simple properties of a neuron demonstrated in the two dimensional real plane

For this illustration we set $n = 2$ and $f = 1$. Now, if we set $y = 0$, the equation of a straight line results as

$$x_2 = -\frac{w_1}{w_2} x_1 - \frac{b}{w_2} \quad (17.3)$$

shown in Figures 17.5 and 17.6 for two different values of b .

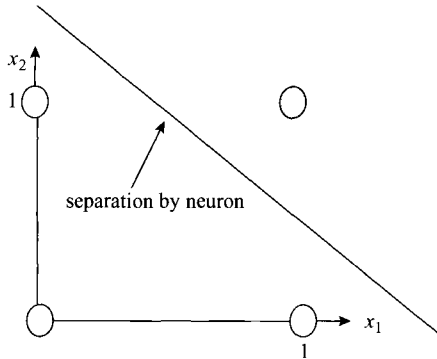

Figure 17.5 Realisation of x_1 AND x_2

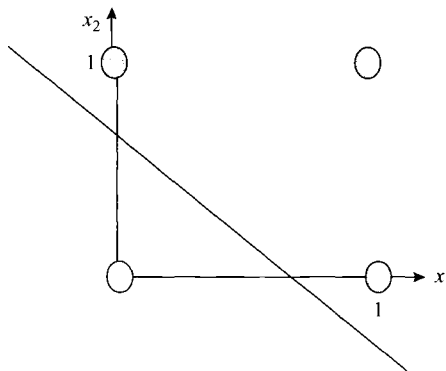

Figure 17.6 Realisation of x_1 OR x_2

It is clear from the figures that the single neuron divides the plane into two regions and can work like an AND or an OR gate, according to the value given to the bias term b . It is also clear, Figure 17.7, that no single line can separate the points $(-1, -1)$, $(1, 1)$ from the points $(1, -1)$, $(-1, 1)$ as is required by the exclusive OR (XOR) function.

One solution for mechanising the XOR function might be to use two neurons to generate two separating lines, and then to feed the output of the two neurons into a third combining neuron to form a region. This leads to the idea that more than one layer of neurons will be needed to allow wider classes of functions to be emulated. We shall return to the topic of multilayer networks shortly but first we consider the case of a single neuron with n inputs.

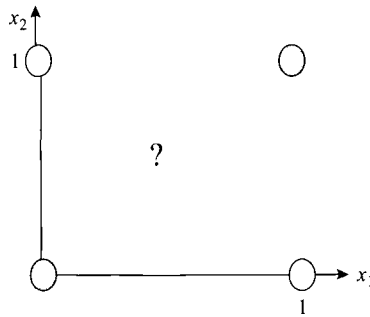

Figure 17.7 No single line separates the points to realise the XOR function

Properties of a single neuron with n inputs

A neuron with n inputs describes a hyperplane that separates \mathbb{R}^n into two disjoint regions, say A and B . The plane with normal $v \in \mathbb{R}^n$ has the equation

$$\langle x, v \rangle = b$$

and this plane is offset by the distance b from the parallel plane

$$\langle x, v \rangle = 0$$

that passes through the origin.

A neuron with weights $w \in \mathbb{R}^n$ and bias $b \in \mathbb{R}$ assigns any $x \in \mathbb{R}^n$ to region A or B using the rule:

$$\langle x, w \rangle > b \quad \Rightarrow \quad x \in A$$

$$\langle x, w \rangle < b \quad \Rightarrow \quad x \in B$$

If the convex hulls of the sets A and B are disjoint then some hyperplane generated by the neuron can give perfect separation of the points into their correct categories.

If the convex hulls of the sets A and B intersect, then no hyperplane can separate the points perfectly and the best one can do is to choose the plane that misclassifies the least number of points.

17.2.4 Multilayer networks

Three layers of interconnected neurons are said to be sufficient to emulate any desired non-dynamic function. The most widely used neural network is perhaps the so-called multilayer perceptron (MLP) (Figure 17.8). An MLP usually has a three-layer architecture with input, hidden and output layers. The number of neurons in each layer and the types of functions embedded in each neuron are chosen by the designer of the network to match the application.

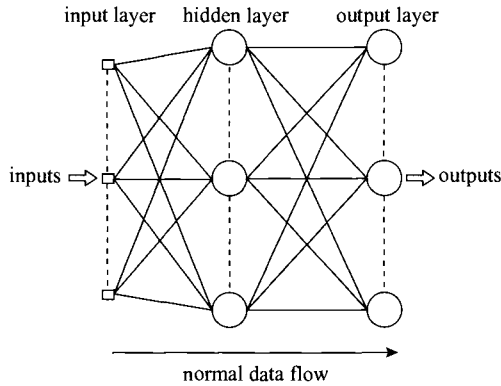

Figure 17.8 A multilayer neural network containing six neurons

17.2.5 Neural network training

Neural network training is the activity of fixing the weights w and the bias terms b throughout the network until the behaviour obtained achieves some given performance objective. The most used training algorithm is back-propagation. This works, in principle, as follows. Training examples in the form of input–output data sets (x, y) are presented to the neural network whose output estimates \hat{y} are recorded. After presentations of k such data sets, we shall be in possession of the information $(x^j, y^j, \hat{y}^j, j = 1, \dots, k)$ and can form the error sum

$$J = \sum (y^j - \hat{y}^j)^2 \quad (17.4)$$

whose minimisation will be the training aim.

Where the neural network has only one layer, back-propagation consists only of adjusting each weight according to the algorithm

$$\Delta w_i = \frac{\partial J}{\partial w_i} \Delta J \quad (17.5)$$

where the partial derivative will only exist if the function f in each neuron is itself differentiable, such as is the case when f is the sigmoidal function.

In multilayered networks, the same principle applies with eqn. 17.5 now having the characteristic that adjustments to weights in early layers can be found only once the later layer corrections have been calculated; hence the name back-propagation.

In practice, the training of a large neural net on industrial data needs to follow a procedure such as the following. The available input data set Q is divided into three subsets, say A, B, C . The network is trained to fit the training set A , with periodic checks to determine the goodness of fit of the partially trained network against verification data set B . The idea of this procedure is that training can be continued too long ('overtraining') such that the network 'learns' the data set A ,

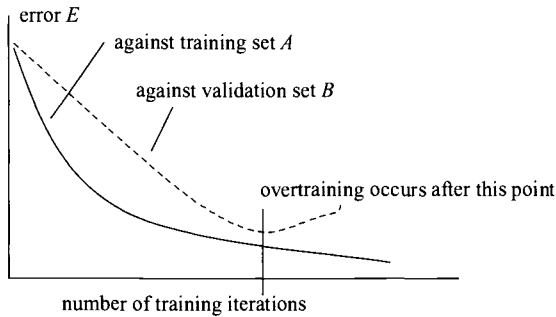

Figure 17.9 Illustrating the phenomenon of overtraining

noise and all, in great detail and no longer captures the underlying function so well as in the earlier stages of learning. By using the set B , the point where overtraining is imminent can be detected, the training stops and the performance against unseen data C can be checked (Figure 17.9).

(The problem of overtaining, or overfitting, is not confined to neural net applications and occurs whenever high order models are fitted to noisy or batch-to-batch varying data from a process of lower order. However, because neural nets tend to be of high algebraic order (a large number of weights to be trained) the overtraining problem is more severe than in classical modelling using, for instance, differential equations.)

17.2.6 Neural network architectures to represent dynamic processes

All the neural networks we have discussed so far have been non-dynamic. That is, input information is immediately processed and appears without storage or delay at the output. In contrast a dynamic process has internal storage and a transient response. To see this, look at what happens to a dynamic system that receives a step input (Figure 17.10). Although the system receives a constant input of unit magnitude, the corresponding output, as shown in the figure, depends on the time. This feature makes neural network training more difficult than simply choosing weights to represent a time-invariant relationship.

Three ways to make neural networks dynamic

(1) Make the network recursive (Figure 17.11). From the figure,

$$(1 + Pz^{-1})y(z) = Pu(z)$$

$$y(z)/u(z) = P/(1 + Pz^{-1}) = Pz/(P + z)$$

(2) Provide the system with delayed inputs alongside normal inputs yielding (Figure 17.12)

$$y(z)/u(z) = P(z + 1)/z$$

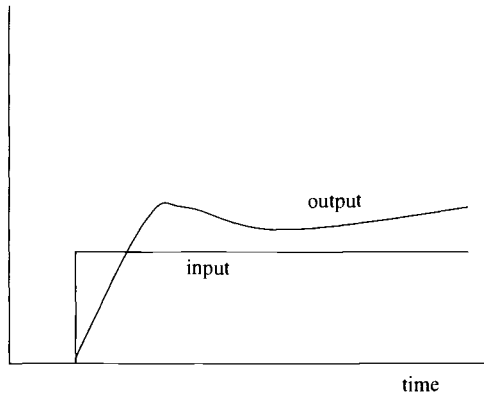
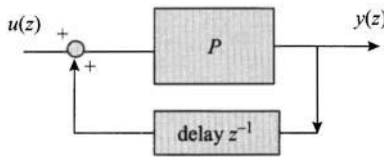

Figure 17.10 A neural net with some sort of dynamic feature is clearly needed to learn this sort of input–output behaviour (in a normal non-dynamic net, the same input will always produce the same output)



The configuration has the first order dynamic equation

$$y(z)/u(z) = Pz/(P+z)$$

which has a first order dynamic

Figure 17.11 Neural element P, made dynamic by feedback (recursive network)

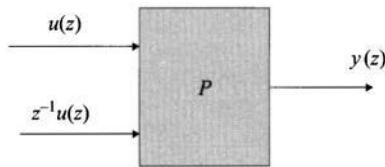

This configuration has the first order dynamic equation

$$y(z)/u(z) = P(z+1)/z$$

Figure 17.12 Neural element made dynamic by delayed inputs alongside normal inputs

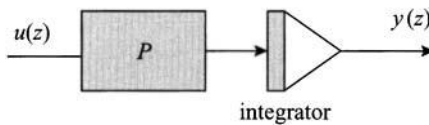

This configuration has the first order dynamic equation

$$y(z) = z^{-1}Pu(z)$$

$$y(z)/u(z) = P/z$$

Figure 17.13 Neural element made dynamic by connection of a separate integrator

(3) Add an integrator to the network yielding (Figure 17.13)

$$y(z)/u(z) = P/z$$

The simple derivations for networks 2 and 3 are similar to that shown for (1) above and are omitted.

Most important industrial processes are non-linear and dynamic. If the dynamics are modelled by a conventional network and the non-linear part by a neural net, excellent results can often be obtained. However, in such a configuration, network training can be difficult since differentiation of the industrial data, with loss of information, may be required if back-propagation approaches are to be used.

The ease of application of neural nets and the speed with which tolerable results are delivered has caused many users to neglect to study the problem properly and to neglect a careful pre-treatment of the data. The two omissions combined can lead to quick and cheap empirical solutions that will be expensive in the longer term. A very successful solution to this problem of excessive empiricism is to embed small scale neural nets within a conventional model of the known dynamics of a process to obtain a state variable structure as shown in Figure 17.14. Such a structure is both mathematically sound as well as transparent (rather than black-box).

17.2.7 Using neural net based self-organising maps for data-reduction and clustering

Self-organising maps (SOMs), particularly using the Kohonen approach, find application in clustering high dimensional data by unsupervised mapping onto a space of reduced dimension. Typically, several hundred input 'patterns' will be input to the SOM which will self-learn a small number of feature patterns at the centre of the classifying clusters.

A SOM, used in this way, can be regarded loosely as a neural-net based non-linear equivalent of a principal components analyser (PCA).

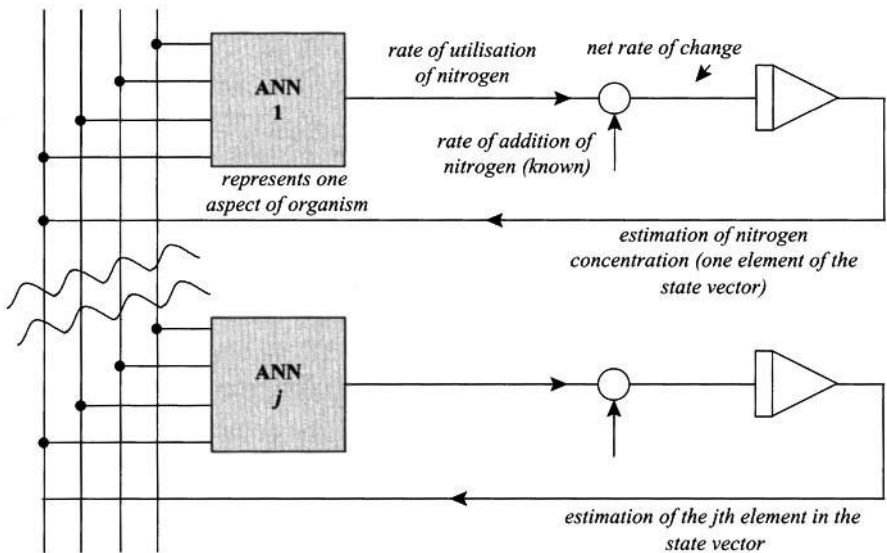

Figure 17.14 How neural nets can be embedded within known dynamics to produce a transparent and mathematically sound state estimator (the example is from a large fermentation process)

17.2.8 Upcoming rivals to neural networks? – support vector machines (SVMs) and adaptive logic networks (ALNs)

Support vector machines (Schölkopf *et al.*, 1998, 1999; Cristianini and Shawe-Taylor, 2000) work by mapping data into high dimensional feature space and in that space, linear functions are fitted to the features.

Adaptive logic networks use a growing self-organising tree of piecemeal linear functions or hyperplanes.

The proponents of these two approaches claim they are faster and more transparent than neural networks, that they have global minima and that they also allow the inclusion of domain knowledge during the modelling process. Under some conditions, ALNs can be reversed so that the output becomes the input. This ability to invert a learned function can have great utility in allowing analysis to be turned into synthesis. ALNs are trained in a similar way to neural nets but they can also be trained by reinforcement learning in which only rough fuzzy feedback such as ‘good’ or ‘poor’ is provided by the supervisor.

17.2.9 Neural nets – summary

- Very simple idea of interconnected neurons that can emulate any function for which numerical examples are available.
- Some theoretical support from Weierstrass’ theorem – any continuous function may be approximated arbitrarily closely by a polynomial.

- An ANN is a ready made modular polynomial with an effective back-propagation method of parameter fitting.
- Not so good as a well custom-constructed non-linear dynamic model but the effort required is very much less.

17.3 Fuzzy set theory and fuzzy logic

17.3.1 Introduction and motivation

To the extent that mathematics is exact it does not apply to the real world; to the extent that it applies to the real world it is not exact

Precision is not truth

Precision and relevance can become almost totally mutually exclusive characteristics

These quotations (from Einstein, Matisse and Zadeh) confirm our experiences that everyday situations are in general too imprecise to be dealt with satisfactorily by mathematical tools.

These three quotations appear to argue in favour of imprecise but reliable human reasoning and action taking. Our everyday observation is that small children rapidly learn to catch a ball, make a swing go really high, ride a cycle or roller skate, all based on ‘acquiring a feel’. The attraction of controllers that might acquire a feel, instead of requiring to be based around a complex quantitative dynamic model, is obvious; controllers based on fuzzy logic go some way towards encoding the human ability to ‘acquire a feel’.

Normal set theory and normal logic are characterised by formalised precision. For instance, once set A has been defined then every element in the universe of discourse belongs either to A or to the complement of A (Figure 17.15). Similarly, every statement in logic produces a statement of either ‘true’ or ‘false’ with no possibility of ‘maybe’.

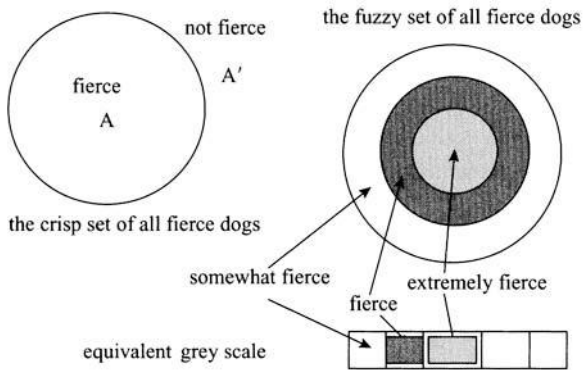

Figure 17.15 Crisp and fuzzy sets

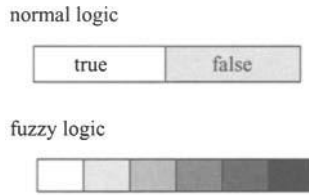

Figure 17.16 *Normal and fuzzy logic*

In contrast, fuzzy set theory is characterised by imprecision, and since human reasoning is based on approximations, here lies the attraction of fuzzy sets. We can, for instance, define the set of all ‘fierce dogs’ or the ‘set of all bad restaurants’ it being understood that there will be different degrees of ‘fierceness’ and ‘badness’, respectively.

The idea of a stepped grey-scale (Figure 17.16) comes to my mind to quantify membership of a fuzzy set. Considering again the set of all fierce dogs, normal set theory would have a crisp 0-1 classification into fierce and non-fierce. Fuzzy set theory would have some well-defined transition from most fierce to not fierce, leading to the concept of a broad fuzzy set boundary, and the idea of degrees of set membership.

It is clear that a fuzzy set can contain more useful knowledge for everyday decision making than can an equivalent crisp set. The attraction of fuzzy logic/fuzzy set theory is that it allows common sense encoding of different levels of intensity and it also allows for the outputting of different levels of activity, leading straightaway to the idea of a fuzzy logic controller.

In particular, fuzzy logic often allows the simple mechanisation of the control actions of a human operator. Mamdani (1976) was the first to publish reports of fuzzy control of a model steam engine while the first successful applications of fuzzy control in industry was to a cement kiln where operators look at many subjective quantities and then adjust a few process variables. Fuzzy logic proved ideal for codifying the operators’ rather ill-defined but reliable control actions at the Danish plant of LA Schmidh (Holmblad and Ostergaard, 1982).

A simple illustration of how a crude rule of thumb can be encoded to produce an easily implementable control algorithm

Imagine a situation where a furnace has the rule of thumb for control as follows:

- If the indicated temperature is LOW (90 °C or less) then set the fuel valve (FV) to 100.
- If the indicated temperature is OK (near to 100 °C) then set the fuel valve (FV) to 10 (this setting having been found to just offset the losses occurring at 100 °C).
- If the indicated temperature is HIGH (110 °C or higher) then set the fuel valve (FV) to 2. (Let us agree that it is not allowable to shut off the fuel completely and that this is the minimum allowable setting.)

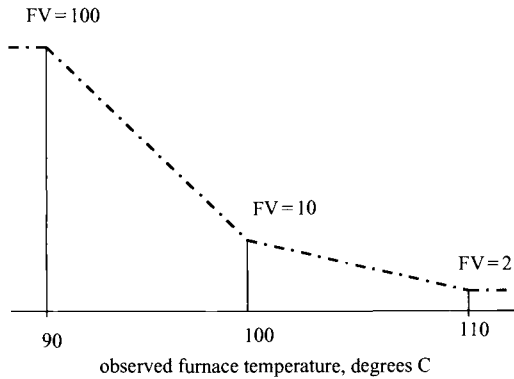

Figure 17.17 *Actions required: solid line – rule of thumb; dotted line – fuzzy logic interpolating curve*

Our chosen fuzzy control algorithm simply interpolates linearly in the above rule of thumb (see Figure 17.17) to give the rule

$$\begin{aligned} \theta \leq 90^\circ &\Rightarrow \text{FV} = 100 \\ 90^\circ < \theta \leq 100^\circ &\Rightarrow \text{FV} = 100 - 90 \frac{(\theta - 90)}{10} \\ 100^\circ < \theta \leq 110^\circ &\Rightarrow \text{FV} = 10 - 8 \frac{(\theta - 100)}{10} \\ \theta > 110^\circ &\Rightarrow \text{FV} = 2 \end{aligned}$$

In use, the algorithm would be run every T seconds, with T being chosen to suit the dynamics. The value of FV would be held constant between calculations.

Fuzzy control can deal with very complex and ill-defined problems that defy mathematical analysis

In a collaborative project between University of Westminster and a UK cement manufacturer, there were around 40 measured or observed variables as inputs to a fuzzy control algorithm but only some three or four variables to be controlled. Fuzzy logic techniques allow such problems to be visualised and driven graphically so that the many interacting and even contradictory laws can be weighted (based on operators' advice) and then combined to form a number of required action shapes. The actions to be implemented at each time step are then found, typically, by finding the centres of areas of those required action shapes.

17.3.2 Some characteristics of fuzzy logic

- Imprecise rules of thumb may easily be encoded.
- Simple structures that parallel human reasoning result.

- The overall operation of a fuzzy logic control can be visualised graphically.
- Using fuzzy logic it is easy and practicable to engineer custom solutions to practical problems using solutions that can successfully encode and then interpolate in operator wisdom and operator feel.
- Fuzzy logic allows mathematics to change its character to emulate the reliable but approximate decision-making methods that humans have evolved so successfully over the centuries.

Disadvantages of control based on fuzzy logic

- Many concepts/tools of conventional control are not easily available (such as frequency response, stability margin, etc).
- Because of the above, fuzzy control solutions have to be checked out empirically over a range of scenarios, rather than being guaranteed mathematically.

17.3.3 References: early pioneering work

HOLMBLAD, L. P. and OSTERGAARD, J. J.: 'Control of a cement kiln by fuzzy logic', in M. M. GUPTA and E. SANCHEZ (Eds): 'Fuzzy information and decision processes' (North Holland, Amsterdam, 1982), pp. 389–399.

This paper surveys the application of fuzzy logic by F.L. Smidth & Co. (FLS) for control of rotary cement kilns. The presentation is given in retrospect, starting in 1974 when FLS heard about fuzzy logic for the first time. The most important milestones are presented, with special emphasis on the role of fuzzy logic.

MAMDAMI, E. H.: 'Applications of fuzzy algorithms for control of simple dynamic plant', *Proc. IEEE.*, 1976, **121**, pp. 1585–1588.

ZADEH, L. A.: 'A rationale for fuzzy control,' *J. Dynamic Systems, Measurement and Control*, 1972, **94**, Series G (3–4).

17.4 Genetic algorithms

17.4.1 Basic ideas

Populations of living organisms have powerful abilities to evolve and to adapt, guided by actual experiences (survival of the *most fit for purpose*). Genetic algorithms imitate natural evolution and natural selection to find solutions to a wide variety of search problems. Natural evolution has a number of features that can possibly be transferred to artificial genetic algorithms. These are:

- (1) A blueprint for a new organism, being a chromosome encoding future characterisation as a string of symbols.
- (2) (In many organisms) a sexual generation mechanism in which two chromosomes from the two parents line up and make a linear exchange of genes from a randomly selected point onward. This mechanism is called *crossover*.
- (3) A (possibly infrequent but important) *mutation* mechanism that ensures that entirely new regions of the search space are occasionally accessed.

- (4) A survival of the ‘most fit for purpose’ strategy. In nature, this strategy is administered by the ability of an organism to survive and even thrive in a competitive environment, at least to a point where it has parented its own offspring.

17.4.2 Artificial genetic algorithms

- (1) Every potential solution to a search problem to be solved by a GA approach must somehow be encoded as a string of (say) binary symbols in such a way that all allowable strings are possible solutions (Figure 17.18).
- (2) Crossover and mutation strategies (Figure 17.19) exist, imitating the natural mechanisms described above.
- (3) A fitness function is used to linearly order any set of possible candidate solutions.

The problem to be solved can be considered amongst the class of hill-climbing problems where visualisation is in the form of a landscape in which we seek the highest

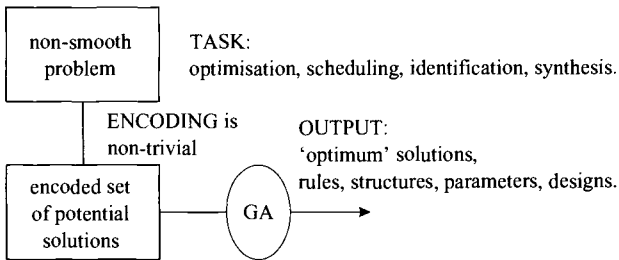

Figure 17.18 Genetic algorithms (GAs) are general purpose optimisation algorithms

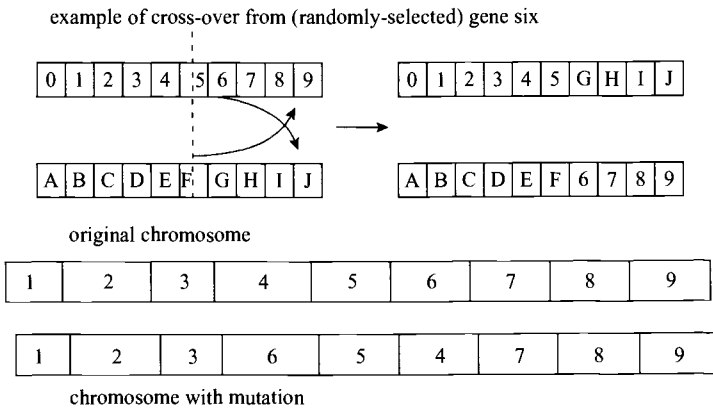

Figure 17.19 Illustration of the crossover and mutation mechanisms

point, equivalent to the point of highest elevation, as measured by the fitness function. In hill-climbing, smooth landscapes with single (i.e. unimodal) maxima are relatively easy to solve whereas noisy landscapes with multiple maxima confuse and delay the algorithm.

All search methods progress more slowly when the problem is non-linear, non-smooth, noisy and with multiple maxima. However, the genetic algorithm, properly set up, has shown itself to be one of the most effective general search methods for such difficult problems.

To understand the particular effectiveness of the genetic algorithm approach, consider a mountainous landscape that represents the search problem with the task being to find the point of highest elevation. The population of candidate solutions is initially randomly and more or less uniformly distributed across the search space. However, as successive generations evolve, the ‘net’ of candidate solutions becomes ever more closely meshed near to possible solutions and correspondingly sparse far away. Thus the search is parallel with statistically increasing probability of search near to likely solutions and although fragmented summits (spiky noise) necessarily delay any method of solution, the genetic algorithm’s lack of direct reliance on seeking directions (which are badly affected by local noise) puts it at an advantage.

Thus, genetic algorithms are able to concentrate most of their attention on the most promising parts of the problem space.

17.4.3 *Genetic algorithms as design tools*

In considering how a set of solution strings develops towards the required solution, it becomes evident that the spatial location of information within the chromosome may be important. Consider using a genetic algorithm to choose the architecture and train the weights of a neural network to model a dynamic batch process for which input–output data are available. In such a case, one segment of the chromosome could represent structure or type of architecture, another segment, numbers of layers and types of embedded functions, while the final layer could represent the numerical parameters that need to be estimated (see Figure 17.20).

It is clear that GAs with their ability to choose between alternative structures and, as it has been shown by Koza *et al.* (1999), their ability to synthesise novel structures and novel solutions, make them very powerful tools.



How a chromosome can be set up to encode

- (a) qualitative structural information (type of architecture)
- (b) quantitative structural information (numbers of nodes/layers, etc.)
- (c) numerical values of parameters for instance for a neural network model of a process

Figure 17.20 Because of an ability to search amongst widely differing disparate structures, a GA can be considered to be a design and synthesis tool

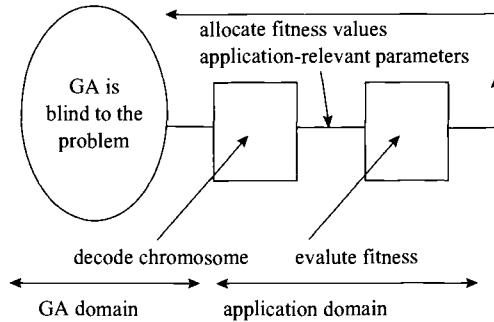

Figure 17.21 How the GA is linked to the problem through the fitness function

17.4.4 GA summary

- Genetic algorithms (GAs) are general purpose optimisation algorithms working, in overview, as shown in Figure 17.21.
- They are based loosely on certain concepts of biological evolution (genes, chromosomes, mutations, generations, [un]natural selection, and survival of the most fit for purpose).

The main steps in classical GA

- Encode the problem so that the solution sought is in the form of a binary string 0110110010... called a chromosome.
- Generate a totally random set of (say 100) chromosomes of the right length to be a solution.
- Evaluate the fitness (a single positive number) of each chromosome.
- Probabilistically, select the most fit chromosomes to be parents for the next generation and produce a new generation from these parents by the crossover mechanism.
- Continue the cycle of generations until a satisfactory solution has been obtained as measured by the fitness value.

GA advantages

- The entire space is searched in parallel, avoiding the solution terminating in local minima.
- GAs are less prone to noise problems than methods that need to evaluate derivatives.
- No knowledge of the problem is needed except for calculation of fitness values.

GA disadvantages

- GA is just a general idea and many difficult application-dependent tasks have to be undertaken (particularly encoding and definition of fitness function, etc.).

- For all but demonstration problems, the computer power/time required to produce a realistic solution may be considerable.
- Much of the GA practitioner's art and skill lies in getting an algorithm to converge when faced with a large problem. Such strategies as incremental evolution (in which coarse approximations are successively produced and then refined) are subjects of current research (Kalganova, 2000).
- GAs have a poor reputation for handling constraints.

17.4.5 *References*

- BANZHAF, W. *et al.* (Eds): 'Genetic programming: an introduction' (Morgan Kaufmann, Heidelberg, Dpunft Verlag, 1998).
- KALGANOVA, T.: 'Bidirectional incremental evolution in evolvable hardware'. Proceedings of the second NASA/DoD Workshop on *Evolvable Hardware*, Palo Alto, California (IEEE Computer Society, Piscataway, NJ, 2000).
- KOZA, J. R. *et al.*: 'Automatic synthesis of both the topology and parameters for a robust controller for a non-minimal phase plant and a three-lag plant by means of genetic programming'. Proceedings of IEEE conference on *Decision and Control*, Chicago, IL, 1999, pp. 5292–5300.
- REEVES, C. R.: 'Genetic algorithms: a guide to GA theory' (Kluwer, Dordrecht, 2002).

17.4.6 *Rivals to GAs? Autonomous agents and swarms*

People are moved in a large city by a mixture of methods ranging from centrally planned underground trains running at scheduled times on fixed routes to a shifting mass of taxis operating largely autonomously. Agents and swarms have some similarity to these taxis: having been set going, they may together solve a very complex problem by a mixture of rivalry and co-operation.

Some specimen references are:

- BONABEAU *et al.*: 'Swarm intelligence: from natural to artificial systems' (Santa Fe Institute of Studies on the Sciences of Complexity, Oxford University Press, New York, 1999).
- FERBER, J.: 'Multi-agent systems: an introduction to distributed artificial intelligence' (Addison-Wesley, Harlow, 1999).

17.5 **Learning systems (systems that learn) with or without supervision**

17.5.1 *Basic ideas*

A machine that can learn by trial and error and that can refine its behaviour over time has very obvious attractions. Further, one could reasonably expect that the ever increasing availability of increased computer power, speed and memory could enable such technologies to be developed and put into application.

Learning in its general sense involves:

1. A learner
2. Something to be learned
3. Examples or selections from what is to be learned displayed to the learner
5. Trial solutions or hypothesis provided by the learner
6. (Possibly) a teacher or a cost function to give feedback to the learner.

17.5.2 Learning versus adaptivity

Adaptivity implies that in response to a change in (say) environment, a system will modify its behaviour always in the same way no matter how many times the operation is performed. However, a learning system, in contrast, faced with a task similar to one encountered previously, can be expected to respond with increasing efficiency – at least until some asymptotic limit to learning has been reached.

17.5.3 Structural characteristics of an abstract learning system

- (a) An initially empty knowledge space that will be populated by knowledge functions that have been accumulated from earlier recorded experiences. The knowledge space with its current set of knowledge functions will be called the knowledge base.
- (b) A knowledge interpreter and interpolator whose aim is to build the best possible knowledge base with the minimum of experimentation. It is the task of this device to choose control strategies that when implemented will produce data rich in information to help fill the knowledge base appropriately.
- (c) An objective function that defines the purpose of the whole exercise. Figure 17.22 indicates the concept. In practice, the learning involved in finding a good control system for a new ‘unknown’ process, such as occurs in the manufacture of a new pharmaceutical product, requires a large number of interacting decisions to be made as shown in Figure 17.23.

Although the procedures used will in broad principle follow the outline shown in Figure 17.22, many of the decisions to be made rely on the inherited wisdom of experts and the sequence of events is still heavily supervised by human experts as shown diagrammatically in Figure 17.24 with the emphasis being initially on finding

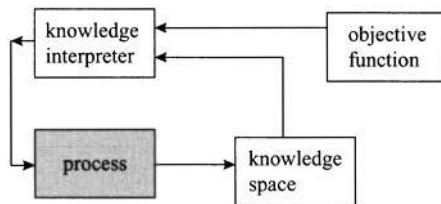

Figure 17.22 Learning control concepts – the structure of an abstract system

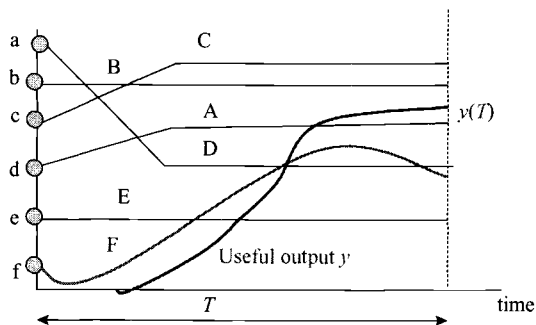
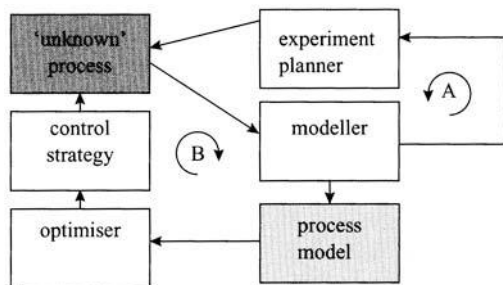

Figure 17.23 The control strategy for a biprocess must fix initial conditions for physico-chemical variables a – e and for bioprocess variable f and stipulate trajectories A – F to be followed during the batch by these variables. The objective is to maximise yield of product y taking into account batch time T



A: model development loop, B: performance optimisation loop

Figure 17.24 Rapid control development for a new batch process

a process model and then changing to a concentration on performance optimisation (Figure 17.25).

17.6 Intelligent systems

17.6.1 The properties that an intelligent system ought to possess

The qualities and properties that an intelligent system *ought* to possess (based on presentations at recent IFAC meetings) are as follows. An intelligent control system, in its most ambitious form, should possess autonomy in terms of:

- self-learning
- self-reconfigurability

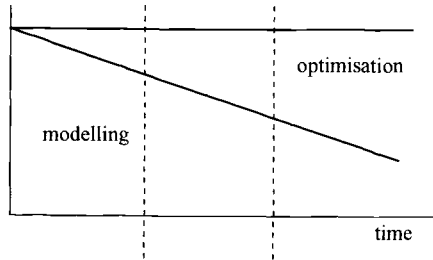

Figure 17.25 Rapid control development for a new batch process: expected progression

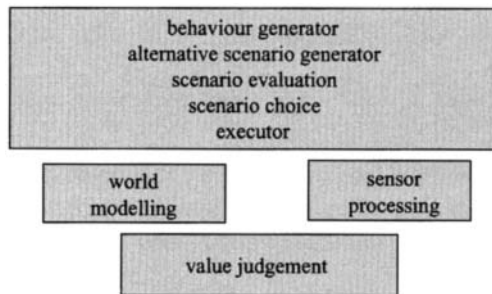

Figure 17.26 NIST-RCS system: an architecture for intelligent system design (Albus, 1997)

- reasoning under uncertainty
- planning
- decision making
- failure detection
- setting control goals (not only attaining them).

It is clear that some current systems do indeed possess several of the quoted properties.

However, it has to be admitted that the state of development of intelligent control systems as measured against the list is still quite modest – perhaps not surprisingly given the ambition built into the list.

More ambitious still is the definition ‘Systems that can deliberate about the past and generate plans and strategies for the future’. Measured against this definition, achievements so far appear pedestrian indeed. However, such a scenario-generating architecture to meet that requirement has been proposed (by Albus, 1997) along the lines of Figure 17.26.

If and when a computer architecture such as the one shown becomes generally available, we shall have an ideal platform to help us to rapid, reliable and transparent implementation of a wide range of intelligent control systems.

17.6.2 Selected references

- ALBUS, J. A.: 'The NIST real-time control system (RCS): an approach to intelligent systems research', special issue of the *Journal of Experimental and Theoretical Artificial Intelligence*, 1997, **9**, pp. 157–174.
- ALBUS, J. S. and MEYSTEEL, A. M.: 'A reference model architecture for design and implementation of intelligent control in large and complex systems', *International Journal of Intelligent Control and Systems*, 1996, **1**(1), pp. 15–30.

17A The idea of a probing controller

Akesson and Hagander (2000) have proposed a so-called probing controller that uses a generic idea for tracking just below invisible varying and unknown constraints that occur in a batch process. The idea is to make probing pulses in the glucose feed rate and to monitor the responses which change as the constraint is approached. By this method, it is possible to detect and avoid a characteristic saturation linked to undesirable by-product formation. Figure 17.27 shows how in *e coli* fermentations, the optimal carbon feed rate will run along invisible constraints. The probing controller finds these boundaries by pulsing the feed rate as shown in Figure 17.28 and observing the nature of the response.

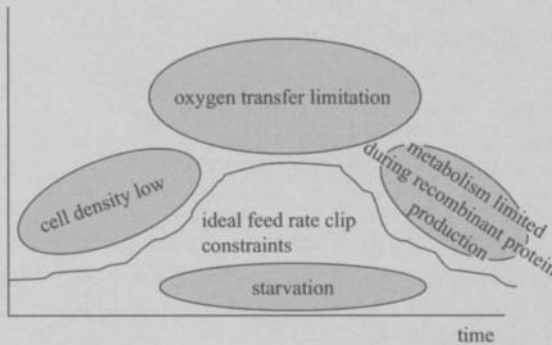

Figure 17.27 Carbon feed rate constraints in *e coli* based expression systems. The trajectory should be as close as possible to the three upper (invisible) constraints

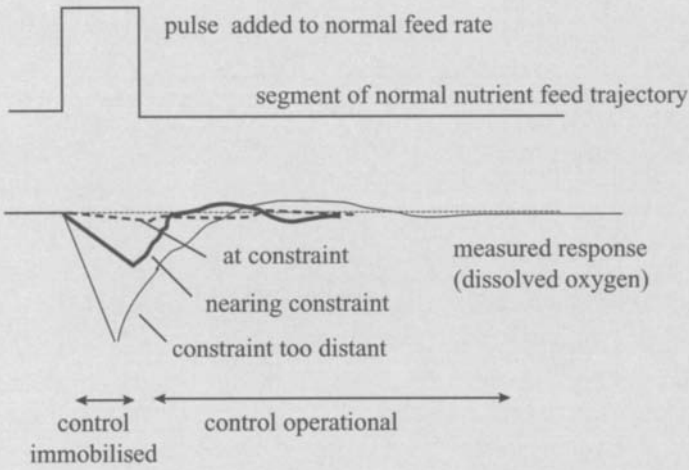

Figure 17.28 How the nearness to the constraint can be inferred from the measured responses to the injected pulses

The idea could be adapted to other processes where variable invisible constraints have to be approached as closely as possible.

AKESSON, M. and HAGANDER, P.: 'A simplified probing controller for glucose feeding in *Escherichia coli* cultivations'. *Proceedings of the IEEE Conference on Decision and Control*, 2000, 5, pp. 4520–4525.

Chapter 18

Review – the development of control theory and the emergence of artificial intelligence (AI) techniques

18.1 A rapid review of how control theory developed

During the period of early industrial development, control was not identified as anything significant since the main preoccupations were with wider basic issues. For instance, the main problems in the early coal industry were with explosions, roof-falls, carbon monoxide poisoning and dust-borne diseases. Once those problems had been largely solved, control systems technology came into play, for instance in the design of remotely operated coal cutters. Present day coal mine managers are now preoccupied with logistics, reliability, information and maintenance. The evolutionary pattern – mechanisation/automation and control/organisation and logistics – can be discerned in almost every industry (Figure 18.1).

Thus, automatic control was scarcely needed until mechanisation had produced the devices and processes that needed to be controlled and in fact it was the requirements of telephony that drove Nyquist (1932), Bode (1945) and coworkers

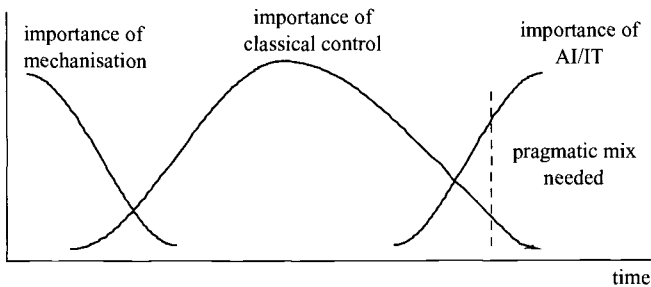

Figure 18.1 The typical evolution: mechanisation/automation/organisation

to develop their frequency response and feedback techniques that were to have such wide applicability much later.

However an early prophet of things to come wrote ‘In this age characterised by huge resources of mechanical and electrical power, these agencies have in many fields almost completely replaced human muscular power. In a similar way the functions of human operators are being taken over by mechanisms that automatically control the performance of machines and processes.’ So wrote H. L. Hazen in a far-sighted paper in 1934. Many of the concepts that Hazen and his contemporaries realised to be possible were slow to materialise because of the absence of reliable devices for computation and information transmission. It required the technical stimulus of World War II, and a long period of development before Hazen’s ideas began to be applied in depth to the more advanced end of the industrial and business spectrum in the 1960s and 1970s. The slow growth was due to the high cost, unreliability and difficulties of application of early computers.

Since all usable systems have to be stable, stability theory is involved implicitly or explicitly in every control application and arguably this is the strongest thread that needs to extend to fully underpin the newer areas where IT, computing and control theory overlap to unify the wider control topic. Early designers of mechanical devices had to ensure stable operation through ingenious mechanical means rather than using control design approaches, which had not yet been invented. For instance, James Watt designed his governor for steam engines in 1788 (Figure 18.2). It uses a form of feedback via a velocity dependent linkage. In practice, the Watt governors often gave poor speed control and allowed oscillatory behaviour. Maxwell (1868) derived the differential equations describing the governed system, linearised the equations about an equilibrium point, and showed that the system would be stable if the roots of the characteristic equation all had negative real parts. He then converted his conclusions into recommendations to add viscous friction to damp the governors. These early examples already illustrate the still continuing trend whereby intelligence is transferred from a designer’s head into a mechanism, a controller or a data base to give increased machine autonomy (Figure 18.3).

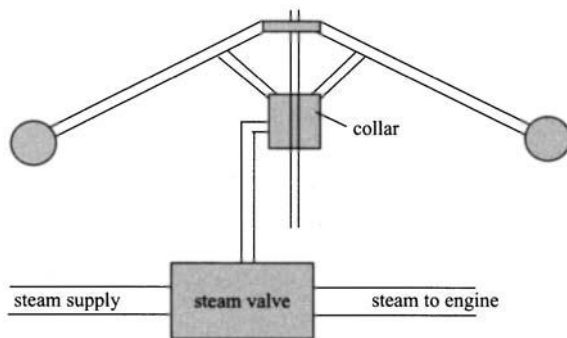

Figure 18.2 *James Watt’s centrifugal governor of 1788 (when the collar lifts, the valve reduces the supply of steam to the engine-feedback control)*

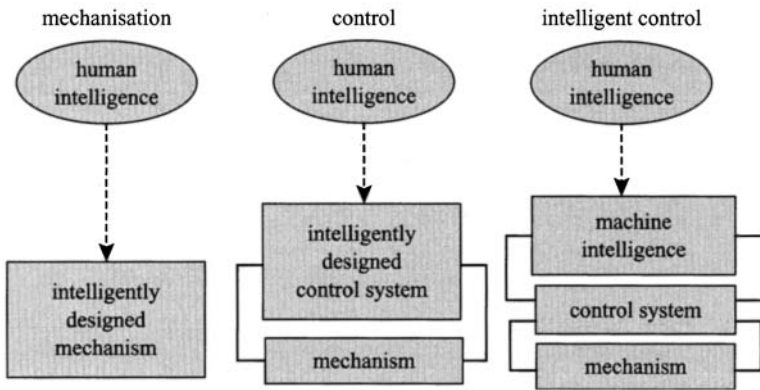

Figure 18.3 Phases of development

During World War II and after, new designs of aircraft, guns and missiles needed new types of control systems that stretched existing knowledge resulting in new research and new powerful techniques.

In the period 1945–1965 these so-called classical techniques, with heavy emphasis on graphical visualisation in the frequency domain and with mathematical underpinning by the theory of functions of a complex variable, were applied with spectacular success to industrial problems, particularly those in the oil, gas, metals and chemical industries. Most of the algorithms passed without difficulty into the computer age as discrete-time versions where they still keep most of the wheels of industry turning or stationary, as required.

In the period 1960–1990, matrix based multivariable theory, with its theoretical foundation being linear algebra and operator theory, developed in earnest and there resulted the beautiful core of linear control theory, Figure 18.4. That figure illustrates the mathematical coherence of the whole control subject. It is that coherence that guarantees the availability of transformations between different representations and domains so that, for instance, the structure, transient and frequency responses and stability characteristics of any given system can be looked at and manipulated in whichever domain is most convenient.

However, the mathematical attractiveness of control theory did not guarantee its universal commercial success.

The drivers for the development of control theory had come from the predominantly academic developers themselves with little pull from the industrial managers whose applications stood to benefit. Not surprisingly, the result was a lot of theory looking for applications and a certain amount of resulting disillusionment all round. Quite a few problems were caused by naïve assumptions, such as the following.

- Accurate unchanging mathematical models of complex industrial processes could be produced at a non-exorbitant cost and that ‘clean’ mathematics could encode the messy realities of the world of work.

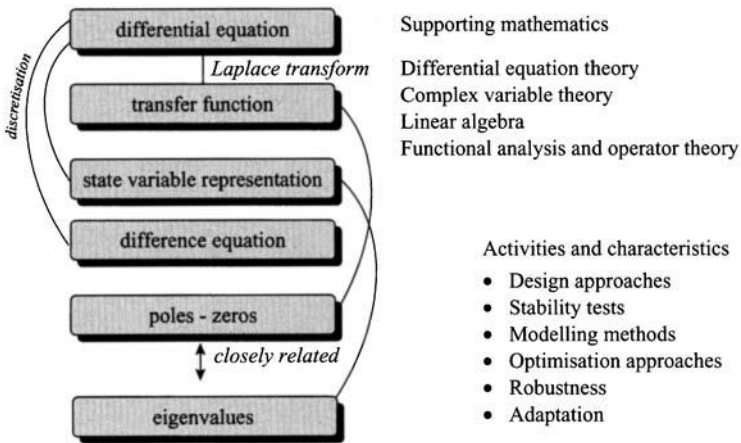

Figure 18.4 *The coherence of control theory*

- The often ill-defined economic aims of a complex plant could reasonably be expressed as a single scalar cost function, thus allowing meaningful optimisation studies to take place.

The failure in the real world of many of the highly rigorous mathematical optimisation techniques resulted in two parallel developments:

- (1) The development of robust control methods, still mathematically deep, but now attempting to quantify and take into account some of the uncertainties and modelling errors that had caused the failures above.
- (2) A return to anthropomorphism with a realisation that imitating nature might have a lot to offer. This theme (imitating nature) combined with the ready availability of computing power and data-collection techniques has resulted in the appearance of a disparate set of so-called AI techniques. Table 18.1 shows a classification of how some of these AI techniques relate to the earlier, more mathematical, expectations of the control world.

18.2 The emergence of AI techniques

Table 18.1 indicates how 1970s expectations of rigorous future algorithms largely turned into 1990s AI realities. To give a little structure to that table, it can be commented that expert systems and fuzzy logic decision making both depend on empirical stored rules, whereas neural networks and genetic algorithms both depend on interactive numerical intensive training/searching to obtain agreement of models with recorded observations.

Other control-related AI techniques, additional to those shown in the figure, have been developed, for instance for pattern recognition, data mining and data clustering.

Table 18.1 How AI-based techniques are taking over from mathematical techniques

1970s expectation	– is (2002) being performed by	– based loosely on
Centralised supervisory algorithm	Expert systems	Human memory Human inference
Precise decision making	Fuzzy logic decision making	Human decision-making
Mathematical models based on physical derivation	Neural networks trained empirically to fit observations	Animal brain operation
Large scale optimisation techniques	Genetic algorithms	Darwinian evolution of species
<i>In general</i>		
Mathematical solutions of all important problems	Powerful but non-rigorous empirical methods	Rather weak imitations of how nature does things

18.3 Control applications are now embedded within an IT infrastructure

Not only is control theory increasingly interacting with all the AI techniques listed above but, even more significantly, all control applications have necessarily become embedded within information technology in order to meet the requirements of Society. The phenomenal increase in cheaply available computer power and in information and data transmission and processing technologies has totally changed the context in which a control system has to operate. Most control systems now have to operate embedded within some IT structure forming part of a large command, control and information network.

18.4 Summary

In summary, the most significant recent developments that have affected control theory are:

- the advent of AI techniques, being a disparate set of rather empirical techniques that are not well linked by an underlying theory;
- the embedding of almost every control activity into an information technology structure.

18.5 How intelligent are AI (artificial intelligence) methods?

What is the purpose of posing this recursive-looking question that is sure to be difficult to answer? The purpose here is to illustrate that there exists at present:

- a set of what have come to be loosely termed AI methods, that in general are useful, disparate, empirical, not very autonomous, weakly underpinned theoretically and rather mundane;

- on-going research into intelligent machines that are increasingly autonomous, that soon will set their own targets and that offer to challenge higher level human thinking.

18.6 What is intelligent control?

Intelligent control as typified by current research into intelligent machines might be considered part of that 'vanguard of innovative developments created to deal with complexity and uncertainty by the application of self-learning and the injection of autonomy'.

Unfortunately for consistency, according to the above (believed to be the author's) definition, most of the techniques that are usually labelled AI techniques fail to qualify as intelligent control methods since they rarely inject significant autonomy into the systems where they are implemented.

Chapter 19

References and further reading

19.1 Library books

The control literature is concentrated, as far as the Dewey system is concerned, into the 629.8 category with particular entries being:

- 629.8312 Control theory
- 629.836 Non-linear and adaptive control
- 629.895 Computer control

Other entries of interest are:

- 511.8 Mathematical models
- 515.352 Ordinary differential equations
- 515.353 Partial differential equations
- 515.625 Difference equations
- 515.64 Calculus of variations
- 515.7 Functional analysis

19.2 Other sources

The contents list of the massive *Congress Proceedings of IFAC*, the International Federation of Automatic Control, published triennially since 1960, and the annual proceedings of the American Control Conference may be scanned as a guide to current and past research directions.

Books, including out of print titles, can be discovered by scanning the British Library or Library of Congress data bases and papers can be found from a variety of on-line abstract data bases. I have found the *EI-Compendex* data base, accessible through the Athens portal, and the public domain 'Citeseer' site to be the most useful.

Many academic library services now offer full text access to a wide range of journals, such as the IEEE range, by access through any networked terminal on campus.

The website of the Control Virtual Library at: http://www.cds.caltech.edu/extras/Virtual_Library/Control_VL.html contains useful information.

19.3 Mainstream control literature

Two highly recommendable books are *Glad and Jung (2000)* and *Trentelman et al. (2001)*. However both texts are advanced in that they require a prior knowledge of linear feedback theory and a certain mathematical sophistication. These prerequisites can be obtained, in part, from standard undergraduate texts. Mainstream control is now a mature topic and this is reflected in the literature for undergraduate courses which is dominated by a few large textbooks that are aimed largely at students preparing for examinations. Typically, these books (see below) are now (2003) in at least their fifth editions and each covers a wide range of topics including, usually, introductory material on modelling, optimisation and state estimation.

D'Azzo and Houpis (1995) around 800 pages; began life in 1960 with 580 pages
Dorf (2001) around 800 pages; began life in 1967 with 400 pages
Franklin and Powell (2002) 850 pages, began life in the 1980s with around 600 pages
 and in similar vein are
Ogata (2002) 850 pages, began life in 1967 with 600 pages
Kuo (2003) now in 8th edition

A large selection of introductory books link their expositions to MATLAB or other computer package solutions. This is a useful strategy and such books may be very attractive. However, I decided not to include them in the following lists since they are so numerous and they tend to date rapidly in phase with the arrival of new versions of the software.

19.4 Older mainstream control books

Many older books have a great deal to offer, having been written during the heady days (one might say 'golden years') when the subject was being created. Amongst the books that I have been privileged to work from and that I would not be without are the following:

Chestnut and Mayer (1959), *Horowitz (1963)*, *Newton, Gould and Kaiser (1957)*, *Truxal (1955)*, *Thaler and Brown (1953)*, *Tou (1964)*, *Zadeh and Desoer (1963)* and from a little later, *Brockett (1970)* and *Wonham (1985)*. *Zadeh and Desoer* is an indispensable book for anyone interested in a rigorous approach to control theory. *Brockett* is a superb book giving a simple yet advanced geometric view of systems behaviour. *Wonham* also gives a welcome geometric viewpoint.

More older books have been listed in the references for the reasons that they are still entirely relevant and that their coverage, approach and level of detail cannot be found in current books. For example: *Balmer and Lewis (1970)* which covers elementary material using a worked-examples approach.

Somewhat harder are the twin books by *Polak and Wong (1970)* and *Desoer (1970)*. Both are very brief.

Harris (1961) and *Maddock (1982)* both take an elementary but comprehensive pole-zero view of systems dynamics.

19.5 Methodologies for economic justification of investment in automation

Please refer to Section 8.5 for recommendations.

19.6 State estimation

Two seminal papers, *Kalman (1960)* and *Kalman and Bucy (1963)*, lay firm foundations for everything that has followed since. The mathematical background is covered by *Ruyngaert and Soong (1985)*. Other suggested references are *Grover-Brown and Hwang (1992)*, *Lee (1964)*, *Middleton and Goodwin (1990)*, *Norgaard et al. (2000)*, *Saridis (1995)* and *Söderström (2002)*.

19.7 Non-linear systems

An important author in the field is *Isidori (1995, 1999, 2001)*. Other suggestions are *Banks (1988)*, *Conte et al. (1999)*, *Fradkov (2000)*, *Henson and Seborg (1997)*, *Marquez (2003)*, *Sastry (1999)* and *Verhulst (1999)*. For more expository treatments, it can be quite useful to consult earlier books such as *Gibson (1963)*, *Graham and McRuer (1961)*, *Minorsky (1947)* and the two slim books by *Aggarwal (1972)* and *Leigh (1983b)*. *Flugge-Lotz (1953, 1958, 1968)* is good on discontinuous control.

Cartwright and Littlewood (1947) and *Van der Pol (1927)* are of historical interest.

In sliding mode control, a system is designed so as to follow one or other switching surfaces, potentially yielding consistent operation despite varying application conditions. See *Misawa (2003)*, *Perruquette and Barbot (2002)*, *Spurgeon and Edwards (1998)*.

19.8 Optimisation

The literature on optimisation is very extensive. The bibliography lists two books that are concerned with inequalities, since a study of these is a prerequisite for

understanding certain approaches to optimisation. The references are *Beckenbach and Bellman* (1961) and *Hardy, Littlewood and Polya* (1967).

There are useful early books on specific topics in optimisation; for instance, *Hestenes* (1966) on the calculus of variations, *Pontryagin et al.* (1964) on the maximum principle and *Bellman* (1957) on dynamic programming.

Recommended general texts are *Bryson* (2002), *Markus and Lee* (1967) and *Sage and White* (1977). *Grimble and Johnson* (1988) is a very comprehensive two-volume set.

Finally, I mention *Pallu de la Barrière* (1967), still in print. This book, by making mathematical demands on the reader, may act as a motivator for those who need a concrete reason for studying further mathematics.

19.9 Distributed parameter systems

Books on partial differential equations, such as the classic by *Sommerfeld* (1949) and *John* (1975), naturally tend to emphasise idealised situations leading to parabolic, elliptic or hyperbolic classical equations with known analytic solutions.

Readable literature on the modelling and control of less idealised distributed parameter systems is fairly rare. The best introductory reference is possibly *Wang* (1964). Other recommended references are *Banks* (1983), *Jai and Pritchard* (1988), and *Omatu and Seinfeld* (1989).

19.10 H_p spaces and H_∞ (robust) control

Please refer to Section 16.9 for recommendations

In addition, it will be worth becoming familiar with a different viewpoint based on Kharitonov's theorem (1979) and which is very straightforward in applications; process uncertainty is dealt with by defining parameters as *intervals* rather than by fixed numbers. A geometrically visualisable Hurwitz type test is then carried out on the edges of the hull representing all the possible Hurwitz polynomials. See *Tan and Atherton* (2000) for a useful summary.

Also relevant is the technique of quantitative feedback theory (QFT) pioneered by *Horowitz* (1993). QFT is a frequency response technique that uses feedback to compensate the effects of unmeasurable process uncertainties or non-linearities. See also *Yaniv* (1999).

Closely associated with robust control are the topics of sensitivity analysis, *Saltelli et al.* (2000) and algorithm fragility, *Istepanian and Whidborne* (2001).

19.11 Neural networks and support vector methods

On neural networks, some theoretical background can be found in *Kecman* (2001), *Vidyasagar* (2002) and *De Wilde* (1997). The application of neural networks in

dynamic modelling, estimation and control is treated in *Hovakimyan et al. (2000)*, *Norgaard et al. (2003)* and *Pham and Liu (1995)*.

Considerable claims are being made for the achievements of new rivals to neural networks in the form of support vector methods, kernel methods and adaptive logic networks. See sample references *Kecman (2001)*, *Lee and Verri (2002)*, *Cristianini and Shawe-Taylor (2000)* or *Schölkopf et al. (1999)*.

19.12 Fuzzy logic and fuzzy control

See *Chen and Pham (2001)* for an introduction and *Abonyi (2002)*.

Zadeh is generally regarded as the inventor of the theory of fuzzy logic; see *Zadeh (1969, 1972)* and *Bellman and Zadeh (1970)*.

Mamdani (1976) created the first laboratory application and *Holmblad and Ostergaard (1982)* pioneered the large-scale industrial application of fuzzy control.

19.13 Genetic algorithms, genetic programming and other parallel evolutionary search methods

Introductory references are *Banzhaf (1998)* and *Reeves (2002)*. *Zalzala and Fleming (1997)* gives a useful overview of applications in engineering. *Koza et al. (1999)* shows how a GP approach backed up by massive computer power can synthesise complex solutions for control applications. *Kalaganova (2000)* describes some of the computational specialism that is involved in solving realistically sized GA problems.

Examples of alternative approaches using multi-agents and swarm intelligence are to be found in *Ferber (1999)* and *Bonabeau et al. (1999)* respectively.

19.14 Intelligent and learning systems

Sources of foundation theory for learning systems are *Tsytkin (1971, 1973)*. Recent learning applications papers are *Hahn et al. (2002)* and *Huang et al. (2002)*.

Albus is a prominent author of forward-looking papers on intelligent machines and their architectures; see *Albus and co-workers (1995, 1996, 1997, 2001)*, *Meystel and Albus (2002)* and *Proctor and Albus (1997)*.

19.15 Adaptive and model-based control

Some of the most well-known model-based approaches are described in the following seminal references:

Dynamic Matrix Control (DMC), *Cutler (1982)*

Model Algorithmic Control (MAC), *Richalet et al. (1977)*

Internal Model Control (IMC), *Garcia and Morari (1982a, 1982b)*

Generalised Predictive Control (GPC), *Mohtadi (1987), Tsang and Clarke (1988)*
Generic Model Control (GMC), *Lee and Sullivan (1988)*

Model Inferential Control (MIC), *Parrish and Brosilow (1984)*

Fast Model Predictive Control (FMPC), *Coales and Noton (1956)*

Other references on predictive and model based control are *Camacho and Bordons (1999), Datta (1998), Forbes et al. (1983), Maciejowski (2001), Matausek et al. (2002), Mo and Billingsley (1990) and Soeterboek (1992)*.

19.16 Stochastic aspects of control

Jones (1988) has produced an interesting contribution linking deterministic with probabilistic design criteria. Most actual systems operate in a probabilistic environment (wind, waves, financial, political vagaries, etc.) whereas a large number of systems are designed, because it is easier, to satisfy simple deterministic criteria. The extent to which systems designed against deterministic criteria will/might satisfy probabilistic criteria is well discussed in the Jones paper.

Suggested references are *Aoki (1967), Papoulis (2002), Saridis (1995) and Söderström (2002)*.

19.17 Some other control topics

For modelling and identification see *Davidson (1988), Godfrey (1993), Sandefur (2002), Seborg et al. (1989) and Söderström and Stoica (1989)*. Large process models frequently need to be reduced in dimensionality as a prerequisite to control system design; some references on model reduction techniques are *Kowalski and Jin (2002), Obinata and Anderson (2000), Prasad (2000), Slone et al. (2002)*.

Control of linear time varying systems is covered by *Kostas and Ioannou (1993)* and of large scale systems by *Koussoulas and Groumpos (1999), Lunze (1991) and Pierre and Perkins (1993)*.

The control of overhead cranes travelling on horizontal tracks is important in sea-container and similar logistics. When such a crane needs to move from one position to another, the application of a simple step will often cause the suspended load to swing excessively. One approach is to apply a pre-shaped input function, designed to achieve a desired response. Such approaches are designated input shaping techniques, *Park et al. (2001), Sahinkaya (2001)*. Of course, input shaping finds application to a range of areas outside crane control.

19.18 General mathematics references

The books quoted here are meant to supply long term mathematics foundation material to indirectly support control theory at research level.

Rosenbrock (1970) gives a straightforward account of mathematics for control.

Hardy (1963), *Binmore* (1981), the old but still useful five-volume *Goursat* (1964) and the French series *Cartan* (1971), *Choquet* (1969), *Dieudonné* (1969), *Godement* (1969) are all recommended.

Further texts to explore are *Birkhoff and Maclane* (1965), *Jacobson* (1963), *Kelley* (1955), *Kelley and Namioka* (1963), *Mostow et al.* (1963), *Protter and Morrey* (1977) and *Halmos* (1950).

Many of the books quoted above are mathematics classics.

Both *Klein* (1924, 1948) and *Armitage and Griffiths* (1969) discuss elementary mathematics from an advanced, often geometric, viewpoint. Finally, mention must be made of the comprehensive high level authoritative works of that most mysterious of authors, *Nicolas Bourbaki* (1988).

19.19 Ordinary differential equations

The formulation, properties and solution of ordinary differential equations occupy a key role in system modelling and simulation. The structural and geometric properties of ordinary differential equations underlie stability theory, state space theory, controllability and optimisation and lend central support to a wide range of research topics in control theory.

A classical mainstream text is *Coddington and Levinson* (1955).

Cesari (1963), *Krasovskii* (1963), *Sanchez* (1968) and *Willems* (1970) are concerned with stability aspects.

Cartwright and Littlewood (1947) and *Descusse* (1989) are concerned with non-linear equations.

Hirsch and Smale (1974) is a superb book that is concerned with fundamental properties.

Arnold (1989) gives a quite different treatment than can be found elsewhere. His book might justifiably have been called ‘Differential equations made difficult’! However, it is a very worthwhile book dealing with elementary ideas from an advanced viewpoint.

Structural aspects are covered in different ways, in *Andranov et al.* (1966), *Bendixson* (1901), *Birkhoff* (1927), *Lefschetz* (1977), *Poston and Stewart* (1976) and *Nemitskii and Stepanov* (1960).

Two papers by *Abd-Ali et al.* (1975) and *Abd-Ali and Evans* (1975) are concerned with structural aspects.

As far as difference equations are concerned, *Van der Pol and Bremmer* (1955) is an admirable text. It is notable that this book is still frequently cited in the literature.

19.20 Differential topology/differential geometry/differential algebra

Heinz Hopf is generally considered to be the leading historic figure in the area. *Hopf* (1983) is a reprint of his classic lectures of some 40 years earlier. *Milnor* (1965),

Spivak (1965) and *Guillemin and Pollack (1974)* are recommended. Even a glance at any of these will make any mathematically inclined person appreciate the beauty of the topic. Differential topology is a beautiful and intuitively appealing subject that is concerned with smooth mappings from non-linear manifolds onto tangent spaces. The subject would appear to be designed for the local approximation of smooth non-linear systems but the take up in that direction was rather slow for some years although differential geometric approaches were used by, for instance, *Sussman and Jurdjevic (1972)* and *Brockett (1978)* to generalise linear systems attributes, such as controllability, to nonlinear systems. In particular, some of the geometric results of *Wonham (1985)* for linear systems have been made applicable to non-linear problems by *Isidori (1985, 1999)* and *Fliess and Glad (1993)*.

More recently, differential algebra has been applied to non-linear control problems, for instance by *Fliess (1985)*. A good self-contained reference to differential algebra and its application to non-linear control problems is *Conte et al. (1999)*. See also *Fliess and Hazewinkel (1986)*.

Other books that may be found useful are *Berger and Gostiaux (1988)*, *Curtis and Miller (1985)*, *Lang (1985)*.

19.21 Theory of equations

Several delightful old books on the theory of equations are: *Chrystal (1964)*, *Barnard and Child (1960)*, *Burnside and Panton (1892)*, *Hall and Knight (1964)* and *Todhunter (1904)*. The material in these references is scarcely to be found in later texts. Another book that contains much useful material not easy to discover elsewhere is *Archbold (1970)*.

19.22 Operator theory and functional analysis applied to linear control

Linear multivariable control models are specially labelled examples of mapping/space configurations. Thus, the natural setting for linear control theory is in one sort of linear space or another – it is only the use of limited horizons that sometimes masks this fact. Amongst the many attractive features that are produced by a function-analytic viewpoint is the very strong and obvious structure that is necessarily imposed on any control problem that is formulated within that framework. For instance, the hierarchy of spaces (topological, linear, metric, Banach, Hilbert) constitutes a range of settings, with decreasing generality, for control problems. The last of these, a Hilbert space setting, is the natural environment for a distributed parameter optimisation problem with quadratic cost function, whereas the first, a topological setting, is so general as to be a qualitative setting for a wide class of problems.

References quoted here are in three categories:

- (i) *Those that illustrate how functional analysis is applicable to control*
 Here we quote *Hermes and La Salle* (1969), *Leigh* (1980), *Leigh* (1988c), *Luenberger* (1969), *Porter* (1966), *Barratt* (1963) and *Rubio* (1971). Of these the book by Porter affords possibly the easiest entry into the topic. There is a very large literature in the form of papers (not quoted below) with principal authors being: *Balakrishnan*, *Butkovskii*, *Lions*, *Wang*, *P.K.C.*
- (ii) *Those that deal with application of functional analysis more generally*
 Here we quote *Curtain* (1977) and specially point out *Moore* (1985). This book, concerned as it is with numerical results, necessarily bridges the gap between an idea and the realisation of that idea because of its algorithmic viewpoint. Another ‘bridging’ reference is *Green* (1969), which is concerned with integral equations.
- (iii) *Those that are concerned with the subject of functional analysis per se*
 Books on operator theory, linear spaces and spectral theory can be considered, for our purposes, to fall into this category. Thus there is a large literature available from which I have selected personal favourites.
 These include: *Akhiezer and Glazman* (1961), *Balakrishnan* (1976), *Berberian* (1974), *Day* (1962), *Dunford and Schwarz* (two volumes 1958 and 1963), *Showalter* (1977) and *Chatelin* (1983).
 The standard works on linear operators are *Hille and Phillips* (1978), a monumental work, and *Riesz and Nagy* (1955).

19.23 Books of historical interest

Early references, *Poincaré* (1892), on celestial motion and on stability, *Maxwell* (1868), *Hurwitz* (1895), *Routh* (1877, 1930), are very interesting.

Maxwell set questions to students on the stability of spinning tops at a date before they had any stability criteria to help them and, while still a student, successfully proved that Saturn’s rings were made up of disparate fragments by a rather general stability argument. Dr Tom Fuller has extracted and edited a number of Maxwell’s works related to control and stability. They form a most valuable linked set of articles and include the topics cited above (*Fuller*, 1979–86). (The work of Hurwitz is discussed in Chapter 7 of this book.)

Bode (1945) and *Nyquist* (1932) are source references on frequency response methods.

Bellman and Kalaba (1964) contains 13 historic control papers. *Basar* (2000) contains 25 annotated seminal papers ending with a paper by Zames from 1981.

Other interesting references are *Evans* (1950, 1954) on the invention of the root locus, *Jury* (1958) on early work in sampled data and *Kochenburger* (1950) on relay control systems. Among other general references of historic interest are *Hazen* (1934a, b) and *Oldenbourg and Sartorius* (1948).

19.24 Miscellany

Guest (1961) is a pre-computer-era book containing highly practicable techniques for fitting curves to time series to achieve interpolation, extrapolation and smoothing.

Guillemin (1935, 1957) are concerned with filter synthesis. These techniques have relevance to the design of systems having particular frequency domain characteristics. (These references are chosen from a wide literature on the topic to be indicative of what is available.)

Kalman, Arbib and Falb (1969) is an example of a whole genre of references concerned with general systems ideas.

Shannon and Weaver (1972) is a slim book that gives an authoritative summary of information theory. The idea that the information represented by a changing situation can be quantified at different levels of approximation by Shannon's ideas is very appealing. Control would then be seen as information capture (measurement), information flow (through a channel of sufficient capacity), and information processing in a controller. However, there are few examples of the ideas having been brought conclusively to bear on a significant control problem.

The books by *Arnold Sommerfeld* (1949, 1950, 1952) are included because of their superb scholarly style.

Aulin (1989) *Brams* (1983), *Bunge* (1959), *Glansdorff and Prigogine* (1971), *Linderholme* (1972), *Segre* (1984), *Prigogine* (1980), *Rosen* (1985), *Toraldo* (1981), *Truesdell* (1984), *Wigner* (1960) are some examples of books that are recommended for stimulating general interest reading.

19.25 Useful tables

A few selected sets of tables are: *Dwight* (1961), contains very comprehensive integral tables; *Gardner and Barnes* (1942) and *McCollum and Brown* (1965) contain extensive tables of Laplace transform pairs. *Prudnikov et al.* (1992) is a very large two volume reference of Laplace transforms and inverses. *Jolley* (1961) is a comprehensive table of series together with information on their summation. *Burrington and May* (1958) is a useful set of statistical tables.

19.26 Alphabetical list of references and suggestions for further reading

- ABD-ALI, A. and EVANS, F. J. (1975): 'Structural aspects of stability in nonlinear systems', *International Journal Control*, **22**, (4), pp. 493–516
- ABD-ALI, A., FRADELLOS, G., and EVANS, F.J. (1975): 'Structural aspects of stability in nonlinear systems', *International Journal Control*, **22**, (4), pp. 481–91 (*The two papers describe the work of Frank Evans' work on Helmholtz decompositions of non-linear systems into two parts; governing stability behaviour and periodic behaviour respectively.*)

- ABONYI, J.: 'Fuzzy model identification for control' (Birkhäuser, Boston, 2002).
(Describes a new approach; instead of attempting to model the operator's decision making process, this new design strategy uses a fuzzy model of the process itself and imbeds this in a model-based control algorithm.)
- AGGARWAL, J. K.: 'Notes on nonlinear systems' (Van Nostrand Reinhold Company, New York, 1972)
- AHRENDT, W. R. and TAPLIN, J.: 'Automatic feedback control' (McGraw-Hill, New York, 1951)
- AKESSON, M. and HAGANDER, P.: 'A simplified probing controller for glucose feeding in *Escherichia coli* cultivations'. Proceedings of the IEEE Conference on *Decision and Control*, Sydney, 2000, vol. 5, pp. 4520–5
- AKHIEZER, N. I. and GLAZMAN, I. M.: 'Theory of linear operations in Hilbert space' (Frederick Ungar Publishing Company, New York, 1961)
- ALBUS, J. S.: 'The NIST real-time control system (RCS): an approach to intelligent systems research'. Special issue of the *Journal of Experimental and Theoretical Artificial Intelligence*, 1997, 9, pp. 157–74
- ALBUS, J. S. and MEYSTEEL, A. M.: 'A reference model architecture for design and implementation of intelligent control in large and complex systems', *International Journal of Intelligent Control and Systems*, 1996, 1(1), pp. 15–30, March
- ALBUS, J. S. and MEYSTEEL, A. M.: 'Engineering of mind: an introduction to the science of intelligent systems' (Wiley, New York, 2001)
- ALBUS, J. S., LACAZE, A., and MEYSTEEL, A.: 'Multiresolutional intelligent controller with unsupervised learning'. Proceedings of IEEE Conference on *Control Applications*, Albany, NY, 1995, pp. 543–8
- ALLEN, D.: 'Economic evaluation of projects' (Institute of Chemical Engineering, London, 1990)
- AMARI, S. I. and OZEKI, T.: 'Differential and algebraic geometry of multilayer perceptrons', *IEICE Transactions on Fundamentals of Electronics, Communications and Computer Sciences*, Tokyo, 2001, E84-A(1), pp. 31–8
- AMBROSETTI, A. and PRODI, G.: 'A primer of nonlinear analysis' (Cambridge Studies in Advanced Mathematics, Cambridge University Press, Cambridge, 1993)
- ANDERSON, B. D. O.: 'Optimal control, linear quadratic methods' (Prentice-Hall, Englewood Cliffs, 1989)
- ANDERSON, J. S. and BRISK, M. L.: 'Estimating the benefits of advanced process control'. Proceedings of IChemE symposium *Advances in Process Control*, York, 1992
- ANDRONOV, A. A. *et al.*: 'Qualitative theory of second order dynamic systems' (John Wiley, New York, 1973)
- ANDRONOV, A. A., WITT, A. A., and CHAIKIN, S. C.: 'Theory of oscillations' (Pergamon Press, Oxford, 1966)
- AOKI, M.: 'Optimization of stochastic systems' (Academic Press, New York, 1967)
- ARCHBOLD, J. W.: 'Algebra' (Pitman Publishing, Bath, 1970)

- ARMITAGE, J. V. and GRIFFITHS, H. B.: 'A companion to advanced mathematics: Parts 1 and 2' (Cambridge University Press, Cambridge, 1969) (*offers some interesting insights*)
- ARNOLD, V. I.: 'Mathematical methods of classical mechanics' (Springer-Verlag, New York, 1978)
- ARNOLD, V. I.: 'Ordinary differential equations' (MIT Press, Cambridge, MA, 1989)
- ÅSTRÖM, K. *et al.* (Eds): 'Control of complex systems' (Springer, London, 2001)
- AULIN, A.: 'Foundations of mathematical system dynamics' (Pergamon Press, Oxford, 1989)
- BALAKRISHNAN, A. V.: 'Applied functional analysis' (Springer-Verlag, New York, 1976)
- BALDWIN, B.: 'Economic justification of process improvement and automation projects'. IEEE Annual Textile, Fiber and Film Industry Technical Conference, Greenville, S. C., 1997, pp. 1–5
- BALMER, L. and LEWIS, C. P.: 'Solution of problems in control engineering' (Pitman Paperbacks, London, 1970)
- BANKS, S. P.: 'State-space and frequency-domain methods in the control of distributed parameter systems' (Peter Peregrinus, London, 1983)
- BANKS, S. P.: 'Mathematical theories of nonlinear systems' (Prentice-Hall, New York, 1988)
- BANZHAF, W. *et al.* (Eds): 'Genetic programming: an introduction' (Morgan Kaufmann, San Francisco, 1998)
- BARNARD, S. and CHILD, J. M.: 'Higher algebra' (Macmillan, London, 1960)
- BARNETT, S.: 'Polynomials and linear control systems' (Marcel Dekker, New York, 1983)
- BARRETT, J. F.: 'The use of functionals in the analysis of non-linear physical systems', *Journal of Electronics and Control*, 1963, **15**,
- BASAR, T.: 'Control theory: twenty five seminal papers (1932–1981)' (IEEE Press, New York, 2000)
- BECKENBACH, E. and BELLMAN, R.: 'An introduction to inequalities' (Random House, L.W. Singer Company, Berlin, 1961)
- BELLMAN, R.: 'Dynamic programming' (Princeton University Press, Princeton, NJ, 1957)
- BELLMAN, R. and KALABA, R.: 'The work of Lyapunov and Poincaré' (Dover Publications, New York, 1964)
- BELLMAN, R. and ZADEH, L. A.: 'Decision-making in a fuzzy environment' (National Aeronautics and Space Administration, Springfield, VA, 1970)
- BENDIXSON, I.: 'On curves defined by differential equations', *Acta Mathematica*, 1924, **24**
- BEQUETTE, W. B.: 'Chemical process control using Matlab' (Prentice Hall, Upper Saddle River, 2003)
- BERBERIAN, S. K.: 'Lectures in functional analysis and operator theory' (Springer-Verlag, New York, 1974)

- BERGER, M. and GOSTIAUX, B.: 'Differential geometry: manifolds, curves and surfaces' (Springer-Verlag, Berlin, 1988)
- BINMORE, K. G.: 'Topological ideas', Book 2 (Cambridge University Press, Cambridge, 1981)
- BIRKHOFF, G. D.: 'Dynamical systems' (AMS, Providence, RI, 1927)
- BIRKHOFF, G. and MACLANE, S.: 'A survey of modern algebra' (Macmillan, New York, 1965)
- BODE, H. W.: 'Network analysis and feedback amplifier design' (Van Nostrand, New York, 1945)
- BODE, H. W.: 'Feedback – the history of an idea'. Proceedings of the Symposium on *Active Networks and Feedback Systems*, Polytechnic Institute of Brooklyn, NY, 1960
- BONABEAU *et al.*: 'Swarm intelligence: from natural to artificial systems' (Santa Fe Institute Studies on the Sciences of Complexity) (Oxford University Press, Oxford, 1999)
- BOURBAKI, N.: 'Elements of mathematics' (eight interrelated textbooks) (Springer-Verlag, Berlin, 1988)
- BRAMS, S. J.: 'Superior beings – if they existed, how would we know?' (Springer-Verlag, New York, 1983)
- BRENNAN, D. J.: 'Process industry economics' (Institute of Chemical Engineering, London, 1997)
- BRISK, M. L.: 'Process control: Theories and profits'. Proceedings of IFAC Congress, Sydney, 1993, vol. 7, pp. 241–50
- BROCKETT, R. M.: 'Poles, zeros and feedback-state space interpretation', *IEEE Trans. Autom. Control*, 1965, **AC-10**, pp. 129–135
- BROCKETT, R. W.: 'Finite dimensional linear systems' (John Wiley, New York, 1970)
- BROCKETT, R. W.: 'Feedback invariants for nonlinear systems'. Proceedings of the VIIth IFAC World Congress, Helsinki, 1978, pp. 1115–20
- BROWN, G. S. and CAMPBELL, D. P.: 'Principles of servomechanisms' (John Wiley, New York, 1948)
- BROWN, J. W. and CHURCHILL, R. V.: 'Complex variables and applications' (McGraw-Hill, New York, 1996, 6th edn)
- BRYSON, A. E.: 'Applied linear optimal control: examples and algorithms' (Cambridge University Press, Cambridge, 2002)
- BRYSON, A. E. and HO, Y. C.: 'Applied optimal control' (John Wiley, New York, 1975)
- BUNGE, M.: 'Causality' (Harvard University Press, Cambridge, MA, 1959)
- BURL, J. B.: 'Linear optimal control: H_2 and H_∞ methods' (Addison Wesley Longman, Harlow, 1999)
- BURNSIDE, W. S. and PANTON, A. W.: 'The theory of equations' (Hodges, Figgis & Co., Dublin, 1892)
- BURRINGTON, R. S. and MAY, JR., D. C.: 'Handbook of probability and statistics with tables' (Handbook Publishers, Inc., Ohio, 1958)

- CAMACHO, E. F. and BORDONS, C.: 'Model predictive control' (Springer, Berlin, 1999)
- CARL, B.: 'Entropy, compactness and the approximation of operators' (Cambridge University Press, Cambridge, 1990)
- CARTAN, H.: 'Differential calculus' (Kershaw Publishing Company Ltd., London, 1971)
- CARTWRIGHT, M. L. and LITTLEWOOD, J. E.: 'On nonlinear differential equations of the second order', *Annals of Mathematics*, 1947, **2**, (48), pp. 472–94
- CESARI, L.: 'Asymptotic behaviour and stability problems in ordinary differential equations' (Springer-Verlag, Berlin, 1963)
- CHANG, S. S. L.: 'Statistical design theory for digital-controlled continuous systems', *AIEE, Trans. P.2*, 1958, **77**, pp. 191–201
- CHATELIN, F.: 'Spectral approximations of linear operators' (Academic Press, New York, 1983)
- CHEN, B. M.: 'Robust and H_∞ control' (Springer Series in Communications and Control Engineering, London, 2000)
- CHEN, C. T.: 'Linear system theory and design' (Holt–Saunders Japan, New York, 1984)
- CHEN, G. and PHAM, T. T.: 'Introduction to fuzzy sets, fuzzy logic, and fuzzy control systems' (CRC Press, Boca Ratan, 2001)
- CHEN, J. and GU, G.: 'Control-oriented system identification: an H_∞ approach' (John Wiley, New York, 2000)
- CHESTNUT, H. and MAYER, R. W.: 'Servomechanism and regulating system design' (John Wiley, New York, 1959)
- CHOQUET, G.: 'Geometry in a modern setting' (Kershaw Publishing Company Ltd, London, 1969)
- CHRYSAL, G.: 'Textbook of algebra', Vols. 1 and 2 (Chelsea Publishing Company, New York, 1964) (*This is a modern reprint of the 1886 original. The reference (like other similar ones in this list) is included because these wonderful old mathematics books are still relevant, are scholarly as opposed to glib, and (sometimes usefully) deal with specifics rather than with generalities.*)
- CLARKE, F. H., LEDYAEV, Y. S., STERN, R. J., and WOLENSKI, P. R.: 'Nonsmooth analysis and control theory' (Springer GTM series, New York, 1998)
- COALES, J. F. and NOTON, A. R. M.: 'An on-off servomechanism with predicted changeover', *Proc. IEE*, 1956, **128**, pp. 227–232
- CODDINGTON, E. A. and LEVINSON, N.: 'Theory of ordinary differential equations' (McGraw-Hill, New York, 1955)
- CONTE, G., MOOG, C. H., and PERDON, A. M.: 'Nonlinear control systems' (Springer Lecture Notes in Control and Information Sciences 242, 1999)
- CORMACK, R. S. and MANTEL, N.: 'Doubt and certainty in statistics', *Jnl. Royal Society of Medicine*, 1990, **83**, (3), pp. 136–7
- COUGHANOWR, L.: 'Process systems analysis and control' (McGraw-Hill, New York, 2002)
- COULSON, C. A. and BOYD, T. J. M.: 'Electricity' (Longmans, London, 1979)

- CRAIG, I. K. and HENNING, R. G. D.: 'Evaluation of advanced industrial control projects: a framework for determining economic benefits', *Control Engineering Practice*, 2000, **8**(7), pp. 769–80
- CRAMER,: 'Mathematical methods of statistics' (Princeton University Press, Princeton, NJ, 1966)
- CRISTIANINI, N. and SHAW-TAYLOR, J.: 'An introduction to support vector machines: and other kernel-based learning methods' (Cambridge University Press, Cambridge, 2000)
- CURTIS, W. D. and MILLER, F. R.: 'Differential manifolds and theoretical physics' (Academic Press, Orlando, FL, 1985)
- CUTLER, C. R.: 'Dynamic matrix control of imbalanced systems', *ISA Trans.*, 1982, **21**(1), pp. 1–6
- DATTA, A.: 'Adaptive internal model control' (Advances in Industrial Control Springer-Verlag, London, 1998)
- DAVIDSON, H.: 'Statistical methods for model development', in SAVAS, E. S. (Ed.): 'Computer control for industrial processes' (McGraw-Hill, New York, 1965)
- DAY, M.: 'Normed linear spaces' (Academic Press, New York, 1962)
- D'AZZO, J. J. and HOUPIS, C. H.: 'Linear control system analysis and design: conventional and modern' (McGraw-Hill, New York, 1995, 4th edn)
- De WILDE, P.: 'Neural network models: theory and projects' (Springer-Verlag, London, 1997, 2nd edn)
- DESCUSSE, J., FLIESS, M., ISIDORI, A. and LEBORGNE, D. (Eds): 'New trends in nonlinear control theory'. Proceedings of International Conference on Nonlinear Systems, Nantes, France (Springer-Verlag, Berlin, 1989)
- DESOER, C. A.: 'Notes for a second course on linear systems' (Van Nostrand Reinhold, New York, 1970)
- DIETRICH,: 'Is there a theory of everything?', *Bulletin of the IMA*, 1994, **30**(11/12) pp. 166–70
- DIEUDONNE, J.: 'Linear algebra and geometry' (Hermann, Publishers in Arts and Science, Paris, 1969)
- DIEUDONNE, J.: 'Infinitesimal calculus' (Hermann, Publishers in Arts and Science, Paris, 1971)
- DOETSCH, K. H.: 'The time vector method for stability investigations' (Royal Aircraft Establishment no. 2495, UDC no. 533.6.054, 1953)
- DORF, R. C. and BISHOP, R. H.: 'Modern control systems' (Prentice Hall, Upper Saddle River, NJ, 2001, 9th edn)
- DULLERUD, G. E. and PAGANINI, F. G.: 'A course in robust control theory: a convex approach' (Springer-Verlag, New York, 2000)
- DUNFORD, N. and SCHWARTZ, J. T.: 'Linear operators, Part 1: General theory' (Inter-science Publishers, New York, 1957)
- DUREN, P. L.: 'Theory of H_p spaces' (Dover Publications, New York, 2000)
- DWIGHT, H. B.: 'Tables of integrals and other mathematical data' (Macmillan, New York, 1961, 4th edn)
- EVANS, W. R.: 'Control systems synthesis by locus methods', AIEE Preprint, 50–51, January 1950 (*pioneering work on the root-locus method*).

- EVANS, W. R.: 'Control-system dynamics' (McGraw-Hill, New York, 1954)
- FERBER, J.: 'Multi-agent systems: an introduction to distributed artificial intelligence' (Addison-Wesley, Harlow, 1999)
- FLIESS, M.: 'A new approach to the non-interacting control problem in nonlinear systems theory, Proceedings of the 23rd Allerton conference, Monticello, 1985, pp. 123–9
- FLIESS, M. and GLAD, S. T.: 'An algebraic approach to linear and nonlinear control' (Birkhauser, Boston, 1993)
- FLIESS, M. and HAZEWINKEL, M. (Eds): 'Algebraic and geometric methods in nonlinear control theory' (Reidel, Dordrecht, 1986)
- FLÜGGE-LOTZ, I.: 'Discontinuous automatic control' (Princeton University Press, Princeton, NJ, 1953) (*Early relay control systems using a sliding mode control system were used in German WW2 flying bombs against London.*)
- FLÜGGE-LOTZ, I.: 'Investigation of a nonlinear control system' (U.S. Govt. Print. Office, Washington, 1959)
- FLÜGGE-LOTZ, I.: 'Discontinuous and optimal control' (McGraw-Hill, New York, 1968)
- FORBES, J. F., JACOBSON, B. A., RHODES, E., and SULLIVAN, G. R.: 'Model based control strategies for commercial grain drying systems.' *Canadian Journal of Chemical Engineering*, 1983, **62**(6), pp. 773–9
- FRADKOV, A.: 'A nonlinear philosophy for nonlinear systems'. Proceedings of the IEEE Conference on *Decision and Control*, Sydney, 2000, **5**, pp. 4397–402
- FRANKLIN, G. F. and POWELL, D. J.: 'Feedback control of dynamic systems' (Prentice Hall, Upper Saddle River, 2002)
- FRENCH, A. P.: 'Einstein: a centenary volume' (Heinemann, London, 1979)
- FREUDENBERG, J. and LOOZE, D.: 'Right half plane poles and zeros and design trade-offs in feedback systems', *IEEE Trans. Automatic Control*, 1985, **30**, (6), pp. 555–65
- FUHRMANN, P. A.: 'Linear systems and operators in Hilbert space' (McGraw-Hill, New York, 1981)
- FULLER, A. T.: 'James Clerk Maxwell's manuscripts relating to control and stability', *Int. Jnl. Control.*, 1979–86, **35**(5), pp. 729–44; **35**(5), pp. 785–805; **36**(4), pp. 547–74; **37**(6), pp. 1197–238; **39**(4), pp. 619–56; **43**(3), pp. 805–18; **43**(4), pp. 1135–68; **43**(5), pp. 1593–612
- GARASHCHENKO, F. G. and LYASHKO, V. I.: 'Adaptive control of linear systems based on a reference model with minimax estimation', *Journal Soviet Automatic Control* (English translation of *Avtomatika*), 1978, **11**(6), pp. 23–35
- GARCIA, C. and MORARI, M.: 'Internal model control – 1. Unifying review and some new results', *Journal Industrial and Engineering Chemistry, Process Design and Development*, 1982a, **21**(2), pp. 308–23
- GARCIA, C. and MORARI, M.: 'Multivariable internal model control'. Annual Meeting, American Institute of Chemical Engineers, paper N 10A, Los Angeles, CA, AIChE, 1982b
- GARDNER, M. F. and BARNES, J. L.: 'Transients in linear systems' (John Wiley and Sons, New York, 1942) (*Contains a large table of Laplace transforms.*)

- GIBSON, J. E.: 'Nonlinear automatic control' (McGraw-Hill, New York, 1963)
- GLAD, T. and JUNG, L.: 'Control theory: multivariable and nonlinear methods' (Taylor and Francis, London, 2000)
- GLANSDORFF, P. and PRIGOGINE, I.: 'Thermodynamic theory of structure, stability and fluctuations' (John Wiley, London, 1971)
- GODEMENT, R.: 'Algebra' (Kershaw Publishing Company, London, 1969)
- GODFREY, K. (Ed.): 'Perturbation signals for system identification' (Prentice Hall, New York, 1993)
- GOURSAT, E.: 'A course in mathematical analysis' (Dover Publications, New York, 1964)
- GRAHAM, D. and MCRUER, D.: 'Analysis of nonlinear control systems' (John Wiley, New York, 1961)
- GREEN, C. D.: 'Integral equation methods' (Nelson, London, 1969)
- GRENSTED, P. E. W.: 'Frequency response methods applied to non-linear systems' (Heywood & Company, London, 1962) (*A small pamphlet that explains the Describing Function very well.*)
- GRIMBLE, M. J.: 'Industrial control systems design' (John Wiley, Chichester, 2001) (*A very comprehensive work that explains a range of H_p methods in detail and then gives numerous detailed industrial examples.*)
- GRIMBLE, M. J. and JOHNSON, M. A.: 'Optimal control and stochastic estimation', Volumes I and II (John Wiley, Chichester, 1988)
- GROVER-BROWN, R. and HWANG, P. Y. C.: 'Introduction to random signals and applied Kalman filtering' (John Wiley, New York, 1992)
- GUEST, P. G.: 'Numerical methods of curve fitting' (Cambridge University Press, Cambridge, 1961) (*Highly practical numerical algorithms are given in detail.*)
- GUILLEMIN, E. A.: 'Communication networks' (John Wiley, New York, 1935)
- GIULLEMIN, E. A.: 'Synthesis of passive networks' (John Wiley, New York, 1957)
- GUILLEMIN, V. and POLLACK, A.: 'Differential topology' (Prentice-Hall, London, 1974)
- HAHN, J. *et al.*: 'Self-learning approach to automatic transmission shift control in a commercial construction vehicle during the inertia phase', *Proceedings of the Institution of Mechanical Engineers, Part D: Journal of Automobile Engineering*, 2002, **216**(11), pp. 909–19
- HAIRER, E. and WANNER, G.: 'Analysis by its history' (Springer UTM series, New York, 1996) (*A fascinating way of presenting the material.*)
- HALL, H. S. and KNIGHT, S. R.: 'Higher algebra' (Macmillan, London, 1964)
- HALMOS, P. R.: 'Measure theory' (Van Nostrand, New York, 1950)
- HALMOS, P. R.: 'Introduction to Hilbert space' (Chelsea Publishing Company, New York, 1957)
- HAND, D., MANNILA, H., and SMYTH, P.: 'Principles of data mining' (MIT Press, Cambridge, MA, 2001)
- HARDY, G. H.: 'A course of pure mathematics' (Cambridge University Press, Cambridge, 1963)

- HARDY, G. H., LITTLEWOOD, J. E., and POLYA, G.: 'Inequalities' (Cambridge University Press, Cambridge, 1967) (*Inequalities are the basis of many optimization methods.*)
- HARRIS, L. D.: 'Introduction to feedback systems' (John Wiley, New York, 1961)
- HAZEN, H. L.: 'Theory of servomechanisms', *J. Franklin Inst.*, 1934a, **218**, pp. 279–331
- HAZEN, H. L.: 'Design and test of a high-performance servomechanism', *J. Franklin Inst.*, 1934b, **18**, pp. 543–80
- HELTON, W. J.: 'Operator theory, analytic functions, matrices, and electrical engineering' (American Mathematical Society, Providence, RI, 1987)
- HELTON, W. J.: 'Classical control using H [infinity] methods: theory, optimization, and design' (Society for Industrial and Applied Mathematics SIAM, 1998)
- HELTON, W. J.: 'Extending H infinity control to nonlinear systems; control of nonlinear systems to achieve performance objectives' (Society for Industrial and Applied Mathematics, 1999)
- HENSON, M. A. and SEBORG, D. E.: 'Nonlinear process control' (Prentice-Hall, Upper Saddle River, 1997)
- HERMES, H. and LASALLE, J. P.: 'Functional analysis and time optimal control' (Academic Press, New York, 1969)
- HESTENES, M. R.: 'Calculus of variations and optimal control theory' (John Wiley, New York, 1966)
- HILLE, E. and PHILLIPS, R. S.: 'Functional analysis and semi-groups' (American Mathematical Society, Providence, RI, 1957)
- HIRSCH, M. W. and SMALE, S.: 'Differential equations, dynamical systems and linear algebra' (Academic Press, New York, 1974)
- HIRSCH, M. W., SMALE, S. and DEVANEY, R. L.: 'Differential equations, dynamical systems, and an introduction to chaos' (Academic Press, Boston, 2003)
- HOLMBLAD, L. P. and OSTERGAARD, J. J.: 'Control of a cement kiln by fuzzy logic' in GUPTA, M. M., and SANCHEZ, E. (Eds) 'Fuzzy information and decision processes' (North Holland, Amsterdam, 1982) pp. 389–99
- HOPF, H.: 'Differential geometry in the large' (Lecture Notes in Mathematics, Springer-Verlag, Berlin, 1983)
- HOROWITZ, I. M.: 'Synthesis of feedback systems' (Academic Press, New York, 1963)
- HOROWITZ, L. M.: 'Quantitative feedback design' (QFT Publications, Boulder, CO, 1993)
- HOVAKIMYAN, N., LEE, H., and CALISE, A.: 'Approximate NN realization of an unknown dynamic system from its input-output history', Proceedings of the American Control Conference, Chicago, IL, 2000, **2**, pp. 919–23 (*This paper considers the problem of using input/output data to realise the dynamic equation for a continuous time nonlinear system. The issue is of paramount importance in control theory, particularly for adaptive output feedback control of unknown plants, when the measurement equation and its derivatives, due to uncertain dynamics, are unknown. Using the universal approximation property of Rumelhart–Hinton–Williams' neural networks theorems are proved establishing the 'memory window*

length' for input(s) and output(s) for both SISO and MIMO systems, needed for approximate realization. This result can be used to solve output feedback problems for a class of nonlinear systems without the need for a state observer.)

- HUANG, S. N., TAN, K. K., and LEE, T. H.: 'Iterative learning algorithm with a quadratic criterion for linear time-varying systems', *Proceedings of the Institution of Mechanical Engineers. Part I: Journal of Systems and Control Engineering*, 2002, **216**(3), pp. 309–16
- HUREWITZ, W.: 'Lectures on ordinary differential equations' (MIT Press, Cambridge, MA, 1958)
- HURWITZ, A.: 'On the conditions under which an equation has only roots with negative real parts', *Mathematische Annalen*, 1895, **46**, pp. 273–80
- ISIDORI, A.: 'Nonlinear control systems' (Springer, Berlin, 1995)
- ISIDORI, A.: 'Nonlinear control systems II' (Springer, London, 1999)
- ISIDORI, A., LAMNABHI-LAGARRIGUE, F., and RESPONDEK, W. (Eds): 'Nonlinear control in the year 2000' (Springer, London, 2001)
- ISTEPANIAN, R. S. H. and WHIDBORNE, J. F.: 'Digital controller implementation and fragility' (Springer-Verlag, London, 2001)
- JACOBSON, N.: 'Lectures in abstract algebra' (Van Nostrand, Princeton, NJ, 1953)
- JAI, A. E. and PRITCHARD, A. J.: 'Sensors and controls in the analysis of distributed systems' (Ellis Horwood, Chichester, 1988)
- JAMES, H. M., NICHOLS, N. B., and PHILLIPS, R. S.: 'Theory of servomechanisms' (McGraw-Hill, New York, 1947)
- JOHN, F.: 'Partial differential equations' (Springer-Verlag, New York, 1982)
- JOLLEY, L. B. W.: 'Summation of series' (Dover Publications, New York, 1961)
- JONES, J. G.: 'An equivalence between deterministic and probabilistic design criteria for linear systems', *Journal of Sound and Vibration*, 1988, **125**(2), pp. 341–56.
- JOSEPH, B. and BROSILOW, C.: 'Inferential control of processes: construction of optimal and suboptimal dynamic estimators', *Journal AIChE J*, 1978, **24**(3), pp. 500–9
- JURY, E. I.: 'Sampled-data control systems' (Wiley, New York, 1958) (*Jury is credited with the invention of the Z transform.*)
- KAILATH, T.: 'Linear systems' (Prentice-Hall, Englewood Cliffs, NJ, 1980)
- KALGANOVA, T.: 'Bidirectional incremental evolution in evolvable hardware'. Proceedings of the Second NASA/DoD Workshop on *Evolvable Hardware*, Palo Alto, CA (IEEE Computer Society, 2000)
- KALMAN, R. E.: 'When is a linear control system optimal', *Trans. ASME Journal of Basic Engineering*, 1964, **86**, pp. 51–60
- KALMAN, R. E.: 'Mathematical description of linear dynamical systems'. Proceedings of the IFAC Congress, London (Butterworth, London, 1966)
- KALMAN, R. E. and BERTRAM, J. E.: 'Control system analysis and design via the second method of Lyapunov', *Trans. ASME Journal of Basic Engineering*, 1960, **82**, pp. 371–93
- KALMAN, R. E. and BUCY, R. S.: 'New results in linear filtering and prediction theory'. *Trans. ASME Journal of Basic Engineering*, 1961, **83**, pp. 95–108

- KALMAN, R. E., ARBIB, M., and FALB, P. L.: 'Topics in mathematical system theory' (McGraw-Hill, New York, 1969) (*Kalman probably did more than anyone to inspire and create the framework of modern control theory.*)
- KECMAN, V.: 'Learning and soft computing: support vector machines, neural networks, and fuzzy logic models' (MIT Press, Cambridge, MA, 2001)
- KELLEY, J. L.: 'General topology' (Van Nostrand, Princeton, NJ, 1955)
- KELLEY, J. L., NAMIOKA, I. *et al.*: 'Linear topological spaces' (Van Nostrand, Princeton, NJ, 1963)
- KHARITONOV, V. L.: 'Asymptotic stability of an equilibrium position of a family of systems of linear differential equations', *Differential Equations*, 1979, **14**, pp. 1483–5
- KLEIN, F.: 'Arithmetic, algebra, analysis' (Dover Publications, New York, 1924)
- KLEIN, F.: 'Geometry' (Dover Publications, New York, 1948) (*The two reprints contain Klein's masterly exposition of 'elementary mathematics from an advanced viewpoint'.*)
- KOCHENBURGER, R. J.: 'A frequency response method for analyzing and synthesizing contactor servomechanisms', AIEE Reprint, 50–51, January 1950 (*Pioneering work on the Describing Function approach.*)
- KOENIG, D.: 'Control and analysis of noisy processes' (Prentice-Hall, Englewood Cliffs, 1991)
- KOSTAS, S. T. and IOANNOU, P. A.: 'Linear time-varying systems: control and adaptation' (Prentice-Hall, Englewood Cliffs, 1993)
- KOUSSOULAS, N. T. and GROUMPOS, P. P. (Eds): 'Large scale systems – theory and applications 1998'. Proceedings of the 8th IFAC/IFORS/IMACS/IFIP Symposium, 15–17 July 1998 (IFAC Proceedings Volumes, Pergamon Press, Oxford, 1999)
- KOWALSKI, M. E. and JIN, J.-M.: 'Karhunen–Loeve based model order reduction on non-linear systems', *IEEE Antennas and Propagation Society, AP-S International Urbana (Digest)*, 2002, **2**, pp. 552–5
- KOZA, J. R. *et al.*: 'Automatic synthesis of both the topology and parameters for a robust controller for a non-minimal phase plant and a three-lag plant by means of genetic programming'. Proceedings of 1999 IEEE Conference on *Decision and Control*, pp. 5292–300. (*Koza and co-workers have been prolific in producing many other papers describing impressive feats of GA driven synthesis of filters, algorithms and metabolic pathways.*)
- KRANC, G. M. and SARACHIK, P. E.: 'An application of functional analysis to the optimal control problem', *J. Basic Eng.*, 1963, **85**, pp. 143–50
- KRASOVSKII, N. N.: 'Stability of motion' (Stanford University Press, Stanford, CA, 1963)
- KUO, B. C.: 'Automatic control systems' (John Wiley, New York, 2003, 8th edn)
- KWAKERNAAK, H.: 'Robust control and H-optimisation – tutorial paper', *Automatica*, 1993, **29**(2), pp. 255–73
- LANG, S.: 'Differential manifolds' (Springer-Verlag, New York, 1985)
- LAUER, H., LESNICK, R., and MATSON, L. E.: 'Servomechanism fundamentals' (McGraw-Hill, New York, 1947)

- LEE, P. L. and SULLIVAN, G. R.: 'Generic model control (GMC)', *Computers and Chemical Engineering*, 1988, **12**(6), pp. 573–80
- LEE, R. C. K.: 'Optimal estimation, identification, and control' (MIT Press, Cambridge, MA, 1964)
- LEE, S.-H., JEON, B.-S., SONG, C.-K. *et al.*: 'Controller design for the bilinear system', IEEE International Symposium on *Industrial Electronics*, Pusan, South Korea, 2001, **3**, pp. 1907–11
- LEE, S. W. and VERRI, A. (Eds): 'Pattern recognition with support vector machines'. First international workshop, SVM 2002, Niagara Falls, Canada (Springer Lecture Notes in Computer Science, 2002)
- LEFSCHETZ, S.: 'Differential equations: geometric theory' (Dover Publications, New York, 1977)
- LEIGH, J. R.: 'Functional analysis and linear control theory', Vol. 156, International Series, Mathematics in Science and Engineering (Academic Press, London, 1980)
- LEIGH, J. R.: 'Modelling and simulation', IEE Topics in Control Series (Peter Peregrinus, London, 1983*a*)
- LEIGH, J. R.: 'Essentials of nonlinear control', IEE Topics in Control Series (Peter Peregrinus, London, 1983*b*)
- LEIGH, J. R.: 'Modelling and control of fermentation processes' (Peter Peregrinus, London, 1987*a*)
- LEIGH, J. R.: 'Applied control theory', IEE Control Engineering Series (Peter Peregrinus, London, 1987*b*, 2nd edn)
- LEIGH, J. R.: 'Temperature measurement and control, with consideration of energy conservation and atmospheric pollution' (Peter Peregrinus, London, 1987*c*)
- LEIGH, J. R.: 'Multivariable systems: functional analysis' in SINGH, M. G. (Ed.): 'Systems and Control Encyclopaedia', pp. 3201–6 (Pergamon Press, Oxford, 1987*d*)
- LEIGH, J. R.: 'Applied digital control: theory, design and implementation' (Prentice-Hall International, New York, 1992, 2nd edn)
- LEIGH, J. R. and THOMA, M. (Eds): 'Control in bioprocessing', Special Issue of *IEE Proceedings*, Part D, 1986
- LI, T. Y. and YORKE, J. A.: 'Period three implies chaos' *Amer. Math. Monthly*, 1975, **82**, pp. 985–92
- LIBBY, C. C.: 'Motor selection and application' (McGraw-Hill, New York, 1960) p. 508
- LINDERHOLM, C. E.: 'Mathematics made difficult' (Wolfe Publishing, London, 1972)
- LUENBERGER, D. G.: 'Optimization by vector space methods' (John Wiley, New York, 1969)
- LUNZE, J.: 'Robust multivariable feedback control' (Prentice Hall, New York, 1989)
- LUNZE, J.: 'Feedback control of large scale systems' (Prentice-Hall International Series in Systems and Control Engineering, New York, 1991)
- MACFARLANE, A. G. J. and ROSENBROCK, H. H.: 'New vector-space structure for dynamical systems', *Electronics Letters*, 1970, **6**(6), pp. 162–3

- MACIEJOWSKI, J. M.: 'Predictive control: with constraints' (Prentice-Hall, Harlow, 2001)
- MACLANE, S. and BIRKHOFF, G.: 'Algebra' (Collier-Macmillan, London, 1967)
- MADDOCK, R. J.: 'Poles and zeros in electrical and control engineering' (Holt, Rinehart and Winston, London, 1982) (*Still useful as a source of simply-understood examples.*)
- MAMDAMI, E. H.: 'Applications of fuzzy algorithms for control of simple dynamic plant', *Proc. IEEE*, 1976, **121**, pp. 1585–8
- MARKUS, L. and LEE, E. B.: 'Foundations of the theory of optimal control' (John Wiley, New York, 1967)
- MARLIN, T. E., BRISK, M. L., BARTON, G. W., and PERKINS, J. D.: 'Experiences from an industry–university study on control benefits', Preprints of Control Systems Conference *Quantifying the Benefits of Process Control*, May 2000, pp. 5–9
- MARQUEZ, H. J.: 'Nonlinear control systems' (John Wiley, Hoboken, NJ, 2003)
- MARTIN, M. and BARTLETT, P. L.: 'Neural network learning: theoretical foundations' (Cambridge University Press, Cambridge, 1999)
- MATAUSEK, M. R., MACIC, A. D., and DACIC, D. B.: 'Modified internal model control approach to the design and tuning of linear digital controllers', *International Journal of Systems Science*, 2002, **33**(1), pp. 67–79
- MAXWELL, J. C.: 'On governors', *Proceedings of the Royal Society of London*, 1868, **16**, pp. 270–83
- McCOLLUM, P. A. and BROWN, B. F.: 'Laplace transform tables and theorems' (Holt, Rinehart and Winston, New York, 1965)
- McLEAN, D.: 'Automatic flight control systems' (Prentice-Hall, New York, 1990) (*Many interesting applications.*)
- MEYSTELE, A. M. and ALBUS, J. S.: 'Intelligent systems: architecture, design, and control' (Wiley, New York, 2002)
- MIDDLETON, R. H. and GOODWIN, G. C.: 'Digital control and estimation' (Prentice-Hall, Englewood Cliffs, 1990)
- MILNOR, J. W.: 'Topology from the differentiable viewpoint' (University Press of Virginia, Charlottesville, 1965)
- MINORSKY, N.: 'Introduction to non-linear mechanics' (J.W. Edwards, Ann Arbor, MI, 1947)
- MISAWA, E. A.: 'Fundamentals of sliding mode control' (John Wiley, New York, 2003)
- MISHKIN, E. and BRAUN, L.: 'Adaptive control systems' (McGraw-Hill, New York, 1961)
- MO, SONG-FENG and BILLINGSLEY, J.: 'Fast-model predictive control of multivariable systems', *IEE Proceedings, Part D: Control Theory and Applications*, 1990, **137**(6), pp. 364–6
- MOHTADI, C.: 'Generalised predictive control', *IEE Colloquium (Digest)*, 1987, **33**, pp. 1–9. IEE Fourth Workshop on Self-Tuning and Adaptive Control. Oxford

- MOLER, C.: '19 dubious ways to calculate the exponential of a matrix', *SIAM Review*, 1978, **204**, pp. 801–37 (*Anyone who sets out to perform the calculation from first principles or who wants to understand what is involved will appreciate this paper.*)
- MOORE, R. E.: 'Computational functional analysis' (Ellis Horwood, Chichester, 1985)
- MORARI, M. and ZAFIRIOU, E.: 'Robust process control' (Prentice Hall, New York, 1989)
- MOSTOW, G. D., SAMPSON, J. H., and MEYER, J.: 'Fundamental structures of algebra' (McGraw-Hill, New York, 1963)
- MUSTAFA, D. and GLOVER, K.: 'Minimum entropy H infinity control' (Springer-Verlag, Berlin, 1990)
- NAYLOR, A. W. and SELL, G. R.: 'Linear operator theory in engineering and science' (Holt, Rinehart and Winston, New York, 1971)
- NEMITSKII, V. V. and STEPANOV, A.: 'Qualitative theory of ordinary differential equations' (Princeton University Press, Princeton, NJ, 1960)
- NEWTON, G. C., GOULD, L. A., and KAISER, J. F.: 'Analytical design of linear feedback controls' (John Wiley, New York, 1957)
- NORGAARD, M., POULSEN, N. K., and RAVN, O.: 'New developments in state estimation for nonlinear systems', *Automatica*, 2000, **36**(11), pp. 1627–38
- NORGAARD, M., RAVN, O., POULSEN, N. K., and HANSEN, L. K.: 'Neural networks for modelling and control of dynamic systems: a practitioner's handbook' (Springer, London, 2003)
- NYQUIST, H.: 'Regeneration theory', *Bell System Tech. Journal*, 1932, **11**, pp. 126–47
- OBINATA, G. and ANDERSON, B. D. O.: 'Model reduction for control system design' (Springer, New York, 2000)
- OGATA, K.: 'Modern control engineering' (Prentice-Hall, Upper Saddle River, 2001, 4th edn)
- OLDENBOURG, R. C. and SARTORIUS, H.: 'Dynamics of automatic control' (ASME, New York, 1948)
- OMATU, S. and SEINFELD, J. H.: 'Distributed parameter systems: theory and applications' (Oxford University Press, Oxford, 1989)
- OMATU, S., KHALID, M., and YUSOF, R.: 'Neuro-control and its applications' (Springer, London, 1996)
- PALLU DE LA BARRIERE, R.: 'Optimal control theory' (Dover Publications, New York, 1967) (*It was an encounter with this book that was the initial motivator for the author to become interested in the operator-theoretic foundations of linear control theory.*)
- PAPOULIS, A.: 'Probability, random variables, and stochastic processes' (McGraw-Hill, Boston, 2002)
- PAPOULIS, A. and ANGELO, E. J.: 'Pole-zero patterns in the analysis and design of low-order systems' (McGraw-Hill, New York, 1964)
- PARK, B. J.: 'Time efficient input shaping control of container crane systems'. Proceedings of IEEE conference on *Control Applications*, September 2000, Anchorage, AK, **1**, pp. 80–5

- PARK, U.-H., LEE, J.-W., LIM, B.-D., and SUNG, Y.-G.: 'Design and sensitivity analysis of an input shaping filter in the z-plane', *Journal of Sound and Vibration*, 2001, **243**(1), pp. 157–71
- PARRISH, J. R. and BROSILOW, C. B.: 'Inferential control applied to industrial autoclaves'. Conference on *Real Time Digital Control Applications*, Proceedings of the IFAC/IFIP Symposium (code 04517), Guadalajara, Mex (IFAC Proceedings Series 1), Pergamon Press, Oxford, 1984
- PERRUQUETTI, W. and BARBOT, J.-P. (Eds): 'Sliding mode control in engineering' (Marcel Dekker, New York, 2002)
- PHAM, D. T. and KARABOGA, D.: 'Intelligent optimisation techniques: genetic algorithms, tabu search, simulated annealing and neural networks' (Springer, London, 2000)
- PHAM, D. T. and LIU, X.: 'Neural networks for identification, prediction and control' (Springer, London, 1995)
- PIERRE, C. and PERKINS, N. C. (Eds): 'Structural dynamics of large scale and complex systems', *American Society of Mechanical Engineers*, December 1993,
- POINCARÉ, H.: 'Les méthodes nouvelles de la mécanique celeste', vol. 1 (Gauthier-Villars, Paris, 1892)
- POLAK, E. and WONG, E.: 'Notes for a first course on linear systems' (Van Nostrand Reinhold, New York, 1970)
- PONTRYAGIN, L. S., BOLTYANSKII, V. G., GAMKRELIDZE, R. V., and MISHCHENKO, E. F.: 'The mathematical theory of optimal processes' (Pergamon Press, Oxford, 1964)
- PORTER, W. A.: 'Modern foundations of systems engineering' (Macmillan Company, New York, 1966)
- POSTON, T. and STEWART, I. N.: 'Taylor expansions and catastrophes' (Pitman, London, 1976) (*Contains useful material on the Inverse Function Theorem.*)
- PRASAD, R.: 'Padé type model order reduction for multivariable systems using Routh approximation', *Computers and Electrical Engineering*, 2000, **26**(6), pp. 445–59
- PRIGOGINE, I.: 'From being to becoming' (W.H. Freeman and Company, New York, 1980)
- PROCTOR, F. M. and ALBUS, J. S.: 'Open-architecture, controllers', *IEEE Spectrum*, 1997, **34**, pp. 60–4
- PROTTER, M. H. and MORREY, C. B.: 'Analytic geometry' (Addison-Wesley Pub. Co., Reading, MA, 1975, 2d edn)
- PRUDNIKOV, A. P. *et al.*: 'Integrals and series', Vols 4 and 5: 'Direct Laplace Transforms and Inverse Laplace Transforms' (Taylor and Francis, London, 1992)
- RAGAZZINI, J. R. and ZADEH, L. H.: 'The analysis of sampled data systems', *AIEE Trans.*, 1952, **71**(II), pp. 225–34
- REEVES, C. R.: 'Genetic algorithms: a guide to GA theory' (Kluwer, Dordrecht, 2002)
- REYNOLDS, T. S.: 'Stronger than a hundred men: a history of the vertical water wheel' (Johns Hopkins University Press, Baltimore, 1983)

- RICHALET, J., RAULT, A., TESTUD, J. L., and PAPON, J.: 'Model algorithmic control of industrial processes' (North-Holland, Amsterdam, 1977)
- RIESZ, F. and NAGY, B. S.: 'Functional analysis' (Frederick Ungar, New York, 1971)
- ROOTS, W. K.: 'Fundamentals of temperature control' (Academic Press, New York, 1969)
- ROSEN, R.: 'Anticipatory systems' (Pergamon Press, Oxford, 1985) (*Rosen dares to challenge the universality of the principle of causality.*)
- ROSENBROCK, H. H.: 'Progress in the design of multivariable control systems', *Meas. Contr.*, 1971, **4**(1), pp. 9–11
- ROSENBROCK, H. H.: 'Structural properties of linear dynamical systems', *Int. J. Control*, 1974, **20**(2), pp. 191–202
- ROSENBROCK, H. H. and MUNRO, N.: 'Alternatives for linear multivariable control! The inverse Nyquist array method' (National Engineering Consortium, Chicago, 1978), pp. 101–37 (*Describes pioneering work that uses Gershgorin circles to model the effects of loop interactions.*)
- ROSENBROCK, H. H. and STOREY, C.: 'Computational techniques for chemical engineers' (Pergamon Press, Oxford, 1966)
- ROSENBROCK, H. H. and STOREY, C.: 'Mathematics of dynamical systems' (Thomas Nelson and Sons, London, 1970)
- ROUTH, E. J.: 'A treatise on the stability of a given state of motion' (Macmillan, London, 1877)
- ROUTH, E. J.: 'Advanced part of the dynamics of a system of rigid bodies' (Macmillan, London, 1930)
- RUBIO, J. E.: 'The theory of linear systems' (Academic Press, New York, 1971) (*Function-analytic viewpoint.*)
- RUYMGAART, P. A. and SOONG, T. T.: 'Mathematics of Kalman–Bucy filtering' (Springer-Verlag, New York, 1985)
- SACCOMANI, M. P., AUDOLY, S., BELLU, G., and D'ANGIO, L.: 'A new differential algebra algorithm to test identifiability of nonlinear systems with given initial conditions'. Proceedings of the IEEE Conference on *Decision and Control*, Orlando, FL, 2001, **4**, pp. 3108–13
- SAGE, A. P. and WHITE, C. C.: 'Optimum systems control' (Prentice-Hall, Englewood Cliffs, NJ, 1977)
- SAHINKAYA, M. N.: 'Input shaping for vibration-free positioning of flexible systems', *Proceedings of the Institution of Mechanical Engineers. Part I: Journal of Systems and Control Engineering*, 2001, **215**(5), pp. 467–81
- SALTELLI, A., CHAN, K. E., and SCOTT, M. (Eds): 'Sensitivity analysis' (Wiley, Chichester, 2000)
- SANDEFUR, J.: 'Elementary mathematical modelling: a dynamic approach' (Brooks Cole, Pacific Grove, CA, 2000)
- SARIDIS, G. N.: 'Stochastic processes, estimation, and control: the entropy approach' (Wiley, New York, 1995)
- SARIDIS, J. S.: 'Entropy in control engineering' (World Scientific, Singapore, 2001)

- SASTRY, S.: 'Nonlinear systems analysis, stability and control' (Springer, New York, 1999)
- SCHIFF, J. L.: 'The Laplace transform: theory and applications' (Springer, New York, 1999)
- SCHÖLKOPF, B. (Ed.): 'Advances in kernel methods: support vector learning' (MIT Press, Cambridge, 1998)
- SCHÖLKOPF, B. J. C., BURGESS, C. J. C., and SMOLA, A. J. (Eds): 'Advances in kernel methods: support vector learning' (MIT Press, Cambridge, MA, 1999)
- SEBORG, D. E., EDGAR, T. F., and MELLICHAMP, D. A.: 'Process dynamics and control' (Wiley, Hoboken, NJ, 2003)
- SEGEL, L. A.: 'Mathematical models in molecular and cellular biology' (Cambridge University Press, Cambridge, 1980)
- SEGRE, E.: 'From falling bodies to radio waves' (W. H. Freeman and Company, New York, 1984)
- SERON, M. M., BRASLAVSKY, J. H., and GOODWIN, G. C.: 'Fundamental limitations in filtering and control' (Springer Series in Communications and Control Engineering, London, 1997)
- SHANNON, C. E. and WEAVER, W.: 'The mathematical theory of communication' (University of Illinois Press, Urbana, 1972) (*Explains quantification of information in a brilliant short book.*)
- SHINSKY, F. G.: 'Process-control systems' (McGraw-Hill, New York, 1979) (*Highly practical.*)
- SHOURESHI, R. A.: 'Intelligent control systems', Paper xx-06, 13th IFAC Triennial World Congress, San Francisco, 1996
- SHOWALTER, R. E.: 'Hilbert space methods for partial differential equations' (Pitman Publishers, London, 1977)
- SINGH, M. G.: 'Systems and control encyclopaedia: theory technology, applications' (Pergamon Press, Oxford, 1989)
- SINGH, M. G.: 'Systems and control encyclopaedia: supplementary volume 1' (Pergamon Press, Oxford, 1990)
- SINGH, M. G.: 'Systems and control encyclopaedia: supplementary volume 2' (Pergamon Press, Oxford, 1992)
- SLONE, R. D., LEE, J.-F., and LEE, R.: 'A comparison of some model order reduction techniques', *Electromagnetics*, 2002, **22**(4), pp. 275–89
- SMALE, S. and WILLIAMS, R. F.: 'The qualitative analysis of a difference equation of population growth', *J. Math. Biol.*, 1976, **3**, pp. 1–4 (*An early reference describing chaotic phenomena.*)
- SÖDERSTRÖM, T.: 'Discrete-time stochastic systems: estimation and control' (Springer, New York, 2002, 2nd edn)
- SÖDERSTRÖM, T. and STOICA, P.: 'System identification' (Prentice-Hall, New York, 1989)
- SOETERBOEK, R.: 'Predictive control: a unified approach' (Prentice-Hall, New York, 1992)
- SOMMERFELD, A.: 'Partial differential equations' (Academic Press, New York, 1949)

- SOMMERFELD, A.: 'Mechanics of deformable bodies', Lectures on Theoretical Physics, Vol. 2 (Academic Press, New York, 1950)
- SOMMERFELD, A.: 'Mechanics'. Lectures on Theoretical Physics, Vol. 1 (Academic Press, New York, 1952) (*Three masterly examples of the writings of Arnold Sommerfeld; he was active in Munich at about the same time that David Hilbert, based in Göttingen, was altering the face of twentieth-century mathematics.*)
- SPIVAK, M.: 'Calculus on manifolds' (W.A. Benjamin, Menlo Park, CA, 1965)
- SPURGEON, S. K. and EDWARDS, C.: 'Sliding mode control: theory and applications' (Taylor and Francis, London, 1998)
- STARK, L.: 'Neurological control systems' (Plenum, New York, 1968)
- STEEN, L. A. and SEEBACH, J. A.: 'Counter-examples in topology' (Holt, Rinehart and Winston, New York, 1970)
- SUSSMANN, H. and JURDJEVIC, V.: 'Controllability of nonlinear systems', *J. Differential Equations*, 1972, **12**, pp. 95–116
- TAKAHASHI, Y., RABINS, M. J., and AUSLANDER, D. M.: 'Control and dynamic systems' (Addison-Wesley, Reading, MA, 1970)
- TAN, N. and ATHERTON, D. P.: 'Stability and performance analysis in an uncertain world', *Computing and Control Engineering Journal*, April 2000, pp. 91–101
- THALER, G. J. and BROWN, R. G.: 'Servomechanism analysis' (McGraw-Hill, New York, 1953)
- TODHUNTER, I.: 'Theory of equations' (Macmillan, London, 1904)
- TORALDO DI FRANCIA, G.: 'The investigation of the physical world' (Cambridge University Press, Cambridge, 1981)
- TOU, J. T.: 'Digital and sampled-data control systems' (McGraw-Hill, New York, 1959)
- TOU, J. T.: 'Modern control theory' (McGraw-Hill, New York, 1964)
- TRENTELMAN, H. L., STOORVOGEL, A. A., and HAUTUS, M.: 'Control theory for linear systems' (Springer Series in Communications and Control Engineering, London, 2001)
- TRUESDELL, C.: 'An idiot's fugitive essays on science' (Springer-Verlag, New York, 1984)
- TRUXAL, J. G.: 'Automatic feedback control systems synthesis' (McGraw-Hill, New York, 1955)
- TSANG, T. T. C. and CLARKE, D. W.: 'Generalised predictive control with input constraints', *IEE Proceedings, Part D: Control Theory and Applications*, 1988 **135**(6), pp. 451–60
- TSIEN, H. S.: 'Engineering cybernetics' (McGraw-Hill, New York, 1954) (*Contains otherwise hard-to-find simple but valuable material about relay control systems.*)
- TSYPKIN, YA. Z.: 'Adaptation and learning in automatic systems' (Academic Press, New York, 1971)
- TSYPKIN, YA. Z.: 'Foundations of the theory of learning systems' (Academic Press, New York, 1973)
- TURNBULL, H. W.: 'Theory of equations' University Mathematical Texts (Oliver and Boyd, Edinburgh, 1963)

- VAN DER POL, B.: 'Forced oscillations in a circuit with nonlinear resistance', *London, Edinburgh and Dublin Philosophical Magazine and Journal of Science*, 1927, **3**, pp. 65–80 (*Pioneering analysis of limit cycle formation in certain types of non-linear second order systems.*)
- VAN DER POL, B. and BREMMER, H.: 'Operational calculus based on the two-sided Laplace integral' (Cambridge University Press, Cambridge, 1955)
- VERHULST, F.: 'Nonlinear differential equations and dynamical systems' (Springer, Berlin, 1996)
- VIDYASAGAR, A.: 'A theory of learning and generalisation: with applications to neural networks and control systems' (Springer series in Communications and Control Engineering, London, 2002)
- VINNICOMBE, G.: 'Uncertainty and feedback: H infinity loop-shaping and the v-gap metric' (Imperial College Press, London, 2001)
- WANG, P. C. K.: 'Control of distributed parameter systems', in LEONDES, C.T. (Ed.): 'Advances in control systems' (Academic Press, New York, 1964), Vol. 1, pp. 75–172
- WANG, Q. G.: 'Relay feedback' (Springer-Verlag, London, 2002)
- WIDDER, D. V.: 'The heat equation' (Academic Press, New York, 1975) (*Included because of its approach to a distributed parameter problem.*)
- WIENER N.: 'The interpolation extrapolation and smoothing of stationary time series' (John Wiley, New York, 1948) (*Because of its perceived value in tracking of enemy aircraft, the work was first published in 1942 during World War 2 as a classified report to Section D2, National Defense Research Committee.*)
- WIENER, N.: 'Cybernetics' (MIT Press, Cambridge, MA, 1961)
- WIGNER, E.: 'The unreasonable effectiveness of mathematics in the natural sciences' (John Wiley, New York, Communications in Pure and Applied Mathematics, Vol. 13, No. 1, 1960)
- WILLEMS, J. L.: 'Stability theory of dynamical systems' (Thomas Nelson, London, 1970)
- WINFREE, A. T.: 'The geometry of biological time' (Springer-Verlag, New York, 1990) (*What time is it at the North Pole, which belongs to all time zones simultaneously? Are there (Amphidromic) points in the oceans where the depth remains constant while the water pivots around like a rotating tilted plane? We live on one of several interacting spinning spheres in a world dominated by yearly, monthly and daily cycles. Additionally, all living organisms contain important biochemical clocks. The book considers all these aspects and more; from a deep but understandable geometric viewpoint.*)
- WONHAM, W. M.: 'Geometric state-space theory in linear multivariable control: a status report', *Automatica*, 1979, **15**, pp. 5–13
- WONHAM, W. M.: 'Linear multivariable control: a geometric approach' (Springer Applications of Mathematics Series, New York, 1985, 3rd edn) (*'the geometry was first brought in out of revulsion against the orgy of matrix manipulation which linear control theory mainly consisted of, not so long ago. But secondly and of greater interest, the geometric setting rather quickly suggested new methods of attacking synthesis which have proved to be intuitive and economical; they are*

also easily reduced to matrix arithmetic as soon as you want to compute' (from Wonham's sleeve note.)

- YANIV, O.: 'Quantitative feedback design of linear and nonlinear control systems' (Kluwer Academic Publishers, Dordrecht, 1999)
- ZADEH, L. A.: 'Toward a theory of fuzzy systems' (National Aeronautics and Space Administration, Springfield, VA, 1969)
- ZADEH, L. A.: 'A rationale for fuzzy control', *J. Dynamic Systems, Measurement and Control*, 1972, **94**, Series G, 3–4
- ZADEH, L. A. and DESOER, C. A.: 'Linear system theory: the state space approach' (McGraw-Hill, New York, 1963)
- ZAK, S. H.: 'Systems and control' (Oxford University Press, Oxford, 2003)
- ZALZALA, A. M. S. and FLEMING, P. J.: 'Genetic algorithms in engineering systems' (Institution of Electrical Engineers, London, 1997)
- ZAMES, G.: 'On the input-output stability of nonlinear time-varying feedback systems, Pts. I and II', *IEEE Trans. Auto. Control*, 1966, **AC-11**(2), pp. 228–38, and (3), pp. 465–77
- ZAMES, G.: 'Feedback and complexity, special plenary lecture addendum'. *IEEE Conference, Decision and Control*, Clearwater, FL, 1976
- ZAMES, G.: 'Optimal sensitivity and feedback: weighted semi-norms, approximate inverses, and plant invariant schemes'. *IEEE Proc. Allerton Conf.*, 1979
- ZAMES, G.: 'Feedback and optimal sensitivity: model reference transformations, multiplicative semi-norms, and approximate inverses', *IEEE Trans. Auto. Control*, 1981, **AC-26**, pp. 301–20
- ZHANG, B. S. and LEIGH, J. R.: 'Design and analysis of a learning control system'. *Proceedings of the IEEE International Conference on Systems, Man and Cybernetics*, 1993, **2**, pp. 618–23. Part 2 (of 5)
- ZHAO, L. *et al.*: 'Neural network based online self-learning adaptive PID control'. *Proceedings of the 3rd World Congress on Intelligent Control and Automation (WCICA)*, Hefei, China, 2000, **2**, pp. 908–10
- ZHOU, K., DOYLE, J. C. and GLOVER, K.: 'Robust and optimal control' (Prentice-Hall, Upper Saddle River, 1996)
- ZIEGLER, J. G. and NICHOLS, N. Z.: 'Optimum settings for automatic controllers', *Trans. ASME*, 1942, **64**(11), p. 69 (*Describes two tuning algorithms that are still the basis for almost all current practical three-term controller tuning.*)
- ZINOBER, A. S. I.: 'Deterministic control of uncertain systems' (Peter Peregrinus, London, 1990)

Notation

The notation conforms to ‘standard usage’ – there are no novel notations. However, the following list, in which symbols are defined with respect to the first chapter in which they appear, may be found useful.

Chapter	Symbol	Meaning
3	G	Operator representing a system to be controlled
	D	Operator representing a controller
	H	Operator representing the behaviour of a composite system
	v	The desired value for y
	y	The measured value of system output
	e	The error between v and y
4	$\mathcal{L}\{ \}$	The operation of Laplace transforming
	$\mathcal{L}^{-1}\{ \}$	The operation of inverse Laplace transforming
	s	The complex variable associated with the Laplace transform
	$\mathcal{F}\{ \}$	Fourier transformation
	*	Convolution
	$\mathcal{R}_{u,y}$	The correlation function between u and y
	ζ (zeta)	Damping factor
	ω	Frequency
	ω_n	Undamped natural frequency
	ω_d	Damped frequency
	ω_r	Resonant frequency
	$R(P)$	Real part of P
	$I(P)$	Imaginary part of P
	σ (sigma)	The real part of a complex number – often used to label the real axis while $j\omega$ is used to label the imaginary axis
5	\dot{y}	$\frac{dy}{dt}$
	\ddot{y}	$\frac{d^2y}{dt^2}$

Chapter	Symbol	Meaning
6	\mathbb{R}^n	n dimensional real space
	$x(k)$	The value of x after k sampling intervals has elapsed
7	$\langle \cdot, \cdot \rangle$	Inner product
	$\ x\ $	The norm of the vector x
	∇v	The gradient of the scalar v
9	δx	A small perturbation in x
	$\frac{\partial u}{\partial v}$	The partial derivative of u with respect to v
	$x_{\mathcal{N}}(t)$	A nominal trajectory that x is, <i>a priori</i> , expected to follow
10	(g_{ij})	The matrix whose typical element is g_{ij}
	Φ	The transition matrix (defined by eqn. 10.18)
	Ψ	The matrix defined by eqn. 10.18
	$\text{dom } L$	The domain of L
	$\text{ker } L$	The kernel of L
	$\text{dim } X$	The dimension of the space X
11	y^*	The signal y after being sampled
	$z\{ \}$	The operation of Z transformation
	z	The complex variable associated with the Z transform
	ω_s	Sampling frequency
	G_0	The transfer function of a zero order hold device
	$G'(s)$	$G_0(s)G(s)$
12	\hat{x}	An estimate of x
	\tilde{x}	The prediction error $x - \hat{x}$
	$x(j j-1)$	A prediction of the variable $x(j)$ made at time $(j-1)$
	$K(j)$	The Kalman gain at time j
	\mathcal{E}	Expected value
14	$[\cdot, \cdot]$	A closed interval
	λ	Lagrange multiplier (do not confuse with usual usage as eigenvalue)
	\mathcal{R}	The reachable set
	$\delta\mathcal{R}$	The boundary of the reachable set
	Ω	The admissible set of controls
	\mathcal{A}	The attainable set
	$\text{sign}(x)$	$= -1$ if $x < 0$, $= 0$ if $x = 0$, $= 1$ if $x > 0$
	sup	supremum
16	$H_p, p > 0$	The family of Hardy spaces
	H_∞	The Hardy space of all stable linear time-invariant continuous time system models
	ΔG	A perturbation to a plant transfer function G
	S	The system sensitivity coefficient
	T	The system complementary sensitivity coefficient
	$\sigma_i(A)$	The i th singular value of some matrix A
	$\bar{\sigma}(A)$ $\underline{\sigma}(A)$	The largest and smallest singular value of A , respectively
	$R(A)$	The range space of A

Chapter	Symbol	Meaning
	$N(A)$	The null-space of A
	A^*	The adjoint of A
	$\delta_\nu(G_1, G_2)$	The distance between two transfer functions as measured by the ν gap metric
	$b_{G,D}$	The distance between a transfer function G and a controller D as measured by the b metric
	$L^P[a, b]$	Lebesgue spaces defined on the interval $[a, b]$
	P	The space of all polynomials
	C^n	The space of all n times differentiable functions
	C	The space of all continuous functions
	\mathcal{C}	The set of all convergent sequences
	\mathcal{C}_0	The set of all sequences convergent to zero
	$l^p, p > 0$	A sequence space

Index

- absolute value norm 191
- adaptive logic networks (ALNs) 234
- additive uncertainty model 210
- AI (artificial intelligence)
 - methods 253–4
 - techniques 225
 - emergence of 252–3
 - taking over from mathematical techniques 253
- Aizerman's conjecture 170
- algorithm
 - choice, guidelines for 152
 - design, approaches to 148–52
- anthropomorphism, return to 262
- anticipatory systems 70–1
- artificial neural networks (ANN)
 - motivation 226–34
- automatic control
 - definition 6–8
 - schemes for industrial application,
 - methodologies for deciding scope and attributes 124
 - systems
 - realisation of 13
 - requirement for 12–14
- automatic feedback control 12–14
 - loops, synthesis of 19–28
- automatic feedback controllers 22
- automation projects 127
- autonomous agents and swarms as rivals to
 - genetic algorithms 242

- backlash 169
- back-propagation 230, 235
- bang-bang nature of unique time-optimal control 191
- bang-bang solution 188
- basis functions 197

- Bell Telephone Laboratories 122
- block-diagram algebra 167
- Bode
 - criterion 85
 - developments of Nyquist approach 86
 - diagram 48, 57, 58, 60
 - feedback amplifier 122
 - magnitude plot 205
 - plot check on stability 146
 - theorem 106, 158–9
 - design constraints caused by 105
 - on stability 102
- books
 - of historical interest 263–4
 - older mainstream control 256
- bounded input 157
- bounded output 157

- calculus of variations 185
- cancellation strategy for unstable pole 99
- carbon feed rate constraints in *e coli* based
 - expression systems 246
- CASE (Computer Aided Software Engineering) tools 16
 - role of 18
- catastrophe theory 136
- Cauchy's integral theorem 34
- Cauchy–Riemann conditions 108
- causality 73
- certainty 68
- chaos 71–3
- chaotic behaviour 71
- classical control theory 106
- classical techniques 251
- closed loop system 70, 154
 - behaviour 215
 - control 207

- closed loop system (*contd.*)
 - moving poles to desirable locations 39–40
 - response 120
 - robust stability of 205
 - step response of open loop system 105
- coherence of control theory 252
- commissioning and maintenance 17
- complex eigenvalues 173
 - see also* eigenvalues
- complex function $G(s)$
 - derivatives of 108
 - singularities of 108
- complex processes 164
- computers as system components 145–6
- conservation of dimension under linear transformations 143
- continuous process under digital control 147
- continuous time processes 163
- continuous typical feedback loop
 - with an integrator in forward path 145
 - laboratory experiment for 146–7
- control
 - algorithm, implementable, illustration of
 - how rule of thumb can be encoded to produce 236–7
 - applications, examples of 8
 - concepts 1–9
 - design
 - alternative approaches 124
 - broad task of 15
 - in frequency domain, basic ideas 47
 - ideas 11–18
 - prerequisites for 11
 - three elements needed for successful 5
 - using frequency response methods
 - general idea of 51–2
 - goals, setting 245
 - ideas, basic 15
 - laws
 - types 19–21
 - intelligent 22
 - loop 6, 7
 - performance limits on 94
 - robust methods, development of 252
 - strategy for biprocess 244
 - system/s
 - design, methodology for 11
 - designer 9
 - examples of 8–9
 - theory definition 3–6
- Control Virtual Library, website of 256
- controllability
 - for multivariable systems, concept of 143
 - tests for 144
- controller/s 19
 - error driven 19
 - fitting into closed loop with process to be controlled 121
 - non-linear 22
 - synthesis
 - methodology 209
 - to place closed loop poles in desirable positions 38–9
- convexity 190
- convolution 41
- coprime factorisation
 - model 211
 - uncertainty model 211
- crisp and fuzzy sets 235
- cruise (automatic highway speed)
 - control 218
- curve extrapolation 165
- damping
 - degree of, illustration of value of
 - derivative term to control 114
 - natural frequency, derivation of formula for 45
- decision making 245
 - model-assisted 165
- degraders of performance of control loops 169
- derivative of function as best linear approximation 134–5
- describing function method 169, 172
 - for analysis of control loops containing non-linearities 170–2
- design justification and implementation, practical aspects of 111
- development
 - affecting control theory 253
 - phases of 251
- Dewey system 255
- diagonal dominance, concept of 138
- digital to analogue convertor transferred for calculation purposes as part of process to be controlled 149–51
- dimensionless frequency 57
- direct controller synthesis 148
- discrete
 - discrete time
 - algorithms 147

- and computer control 145–58
 - difficulties in moving from differential equations to approximating difference equations 153
 - discretisation 153
 - quadratic behaviour 154–6
- and continuous time, models a unified approach 141–3
- devices that can change their state only at 145–6
- limit of 156
- loop 150
- distributed systems 195–9
 - modelling approaches 195
 - ‘Fourier type’ approach 197
- disturbance rejection 208
- disturbing signals 164
- Dodgson, Charles L. 79
- doubt 68
- Doyle, contributions to developing robust control methods 86
- dynamic programming, method of 185
- dynamic systems 2, 6
- dynamics of water-driven turbine systems 88

- economic dynamic programming 127
- economic element 24
 - under closed loop control 25
- economic justification of investment in automation
 - methodologies for 124
 - references on 130
- EI-Compendex data base 255
- eigenvalues 175
- eigenvectors 173, 175
- Einstein, A. 69
- equality constants 185
- error driven system 14
- Euclidian norm 190, 191
- Euler–Lagrange conditions 183
- Evans, root locus interpretation of Nyquist approach 86
- evolutionary pattern of
 - mechanisation/automation and control/organisation and logistics 249
- experimentation on plants to assist in model development 79–81

- failure detection 245
- feedback control 5
 - alternatives to 28
 - principle 24
 - of process with uncertainty 205
 - strategies general conditions for success of 27–8
 - systems, design of 139
 - working of 22–7
- feedback controllers, efficiency in controlling unknown phenomena 111
- feedback loop 14, 19–21, 24
 - design using frequency response and stability 50–1
- feedback systems 2
- feedforward control 28
- Ferrari’s method 87
- fictitious discontinuities 197
- filter synthesis 41
- Fisher’s criterion of maximum likelihood 67
- Fourier
 - expansion 171
 - transformation 41, 43, 214
 - models of linear dynamical systems 201
- ‘Fourier type’ modelling 196
- frequency response
 - curve 40
 - of a linear system 48
 - methods 47–60, 167
 - design using 47
 - obtained by calculation from a differential equation 53–5
 - of a second order system 56–9
 - and stability 49
 - of a system
 - obtaining experimentally 52
 - with poles and/or zeros near to the imaginary axis 58
 - testing 55–6
- friction characterisation 176
- future behaviour of systems 4
- fuzzy control in very complex and ill-defined problems 237
- fuzzy feedback 234
- fuzzy logic 225–46
 - characteristics of 237–8
 - disadvantages of control based on 238
- fuzzy set theory 235–8
 - and fuzzy logic, motivation 235–7

- GA *see* genetic algorithms
- gain 48
 - plus compensation approach 150

- Gauss's criterion of least squares 67
- Gaussian noises 160
- general form of all control systems 9
- general systems ideas 1–3
- generation of a control sequence 142
- genetic algorithms (GAs) 225–46
 - advantages 241
 - artificial crossover and mutation strategies 239
 - basic ideas 238–42
 - classical, main steps in 241
 - as design tools 240–1
 - as general purpose optimisation algorithms 239
 - summary 241
- Gershgorin's theorem from linear algebra 138
- Guillemin's technique 41

- H_∞ 202
 - control loop design simple view of 204–6
 - control references on 222
 - design approaches, specification of the ΔG envelope 210
 - effect of choice of p on nature of norm 202
 - frame design tool 214–18
 - loop shaping 218
 - metrics δ_v and b_{GD} 215, 218
 - use of the v gap metric 215
 - visualisation of triangle inequality 217
 - methods
 - introduction to robust control design using 201–22
 - motivation 201
 - norms deriving from dynamic process models 211–14
 - eigenvalues of rectangular matrix A 212–14
 - relations between frequency and time domains 213
 - singular values and eigenvalues 211–13
 - robust control design methods
 - using adaptivity versus robustness 219–22
 - using shape of unit ball in real 2-space for different values of p 203
 - suffix p 202
- Hardy spaces 220, 221
 - notation 222
 - references on 222
- and their relevance to control problems 201
- heating process under closed loop control 25
- high-fidelity amplifications of signals 122
- Hilbert space 262
- hill-climbing for estimation of unknown model parameters, principle of 65
- human temperature regulation system, representation of 2
- Hurwitz
 - criterion 88
 - method of 88
 - type test 258
- Hurwitz Routh
 - criteria 85
 - stability information from coefficients of differential equation 86
- hydraulic actuator 95
- hyperplane 193
- hysteresis 169

- ideal feedback controller 27
- ideal situation modelling system 62
- industrial processes, interlinked, set of 124
- inequality constraints 185
- infinite velocity spike 188
- innovation sequence 164
- input/output
 - characteristic 167
 - stability 205
 - system simple 31
- integrator 48
- intelligence systems, selected references 246–7
- intelligent control, definition 254
- intelligent systems 225–47
 - design architecture for 245
 - properties necessary 244–6
- interdeterminism 75
- internal energy storage, system with 6
- International Date Line 79
- International Federation of Automatic Control Connectedness (IFAC) Congress Proceedings of 255
 - meetings 244
- inverse Laplace transformation 30, 97, 140
- inverse Z transforms, non-uniqueness of 157
- investment strategy tool
 - for n linked processes 128
 - for six processes with three choices at each stage 128
- IT infrastructure control, applications embedded within 253

- iterative search in parameter space, visualisation of 65
- Jacobian matrix 134
- jump resonance 169
- jury sampled data formulations 86
- justification histogram 125, 127
- Kalman filter 160–2
 - connected to a process with inaccessible state 161
 - illustration of principle of 160
 - and prediction 159–66
 - prerequisites for successful application of 163–4
 - theory 163
- Kalman gain 162
 - matrix 161
- Kalman's conjecture 170
- kernel, loss of dimension into 144
- Kharitonov's theorem 258
- Lagrange multipliers 183, 184
- Laplace transformation 20, 43, 54, 97, 139, 213, 214
 - convergence of integral that defines 30–1
 - definition of 29
 - methods 140
 - models of linear dynamical systems 201
 - problems with 0^- and 0^+ 31
 - properties of 42
 - simplification of system, representation and manipulation 29
 - techniques 29
 - use in control theory 31–2
- Laurent series 109
 - and associated concept of residues 34
- learning system 225–46
 - abstract, structural characteristics of 243–4
 - learning versus adaptivity 243
 - with or without supervision 242–4
 - basic ideas 242–3
- Lebesgue spaces 220–1
 - integration, theory of 203
 - notation 222
- limits of control performance 27, 83–108
 - integral constraints in time domain 104–5
 - non-minimum phase systems 103
- linear control theory 176
- linear envelope that bounds class of non-linearities 170
- linear methods 168
- linear multivariable control models 262
- linear multivariable optimisation
 - problems 202
- linear second-order systems in state plane 172–4
- linear system 2
 - characteristics 2
 - stability tests 88, 89
- linear time-invariant continuous time system
 - models 202
- linearisation 131–6
 - concept of transversality 136
 - definition 131–2
 - inverse function theorem 135
 - motivation for 131
 - about nominal trajectory, illustration 133–4
- linearity/non-linearity, loose classification of systems 168
- literature, mainstream control 256
- local
 - and global stability 90
 - stability in phase plane, region of 91
- loop
 - containing linear dynamic system and non-linear non-dynamic system 171
 - shaping
 - concept 209, 210
 - techniques 102
- Lyapunov
 - first method 169
 - second (direct) method 169
 - geometric interpretation of 92–3
 - for stability determination 91–3
 - theorem 191
 - two stability theorems 85, 86
- Magellan, Ferdinand 79
- manually controlled process 7
- mapping
 - of complex functions 106–8
 - and encirclement 107
- Mason's rules 33
- mathematical modelling 61–81
 - approaches to 61
 - causality and time-ordering 73–4
 - determinism and predictability 75
 - illustration of difficulty of 76–9
 - reversibility and irreversibility 75
- mathematical models
 - analysis of residuals 68–81
 - of complex industrial processes 251

- mathematical models (*contd.*)
 - for the development of 62
 - fixing of parameters 67
 - parameter estimation 67
 - regression analysis 67
 - types of undesirable bias 68
- matrix
 - based multivariable theory 251
 - and vector methods 167
- maximum value norm 191
- Maxwell
 - Adam's Prize essay 85
 - exam question 85
 - milestones in stability theory 86
- minimum phase system 102
- mixed sensitivity approach 209
- modelling
 - complex physical systems 74
 - difficulties 66
 - of distributed systems
 - alternative approaches to 196–9
 - representation of a spatial region as the summation of elemental regions 196
 - procedure 66
 - social and political phenomena 76
 - system based on data obtained by experimentation 62–4
- models, construction from theoretical considerations 64
- multilayer networks 229–30
- multiplicative uncertainty model 210
- multivariable linear processes 137
- multivariable matrix formulations 137
- multivariate process 137

- 'natural' element spatial regions 197
- negative feedback systems 108
- neural element made dynamic 233
 - by feedback 232
- neural networks (nets) 225–46
 - architectures to represent dynamic processes 231–3
 - based self-organising maps using for data-reduction and clustering 233–4
 - basic abilities of 226
 - basic building block 227
 - dynamic, three ways to make 231
 - modelling 62
 - summary 234
 - training 230–1
 - 'weights' 226
- neuron 227
 - with n inputs properties of a single 229
 - simple properties demonstrated in two dimensional real plane 227–9
 - typical architecture of 227
- New York to San Francisco telephony 122
- NFL [No Free Lunch] syndrome 106–8
- Nichols chart 60
- NIST-RCS system 245
- non-Gaussian disturbance signals 164
- non-linear control 112
- non-linear dynamic systems 71
- non-linear input-output black box 226
- non-linear processes 163
- non-linear systems 167
 - approaches to analysis of 169–70
 - numerical simulation of 168
 - second-order, in state plane 174–5
- non-linearity 167–77
 - definition 167
- non-minimum phase systems 101–2, 105
- notation 283–5
- Nyquist
 - array methods 137
 - criterion 85, 108
 - diagram 60
 - illustrating stability inequality 208
 - graphical frequency response method 86

- off-the-shelf approach to control of unknown process 113–23
- on–off control 112
- open loop
 - models 215
 - optimisation strategies 186
 - step test 115
 - systems 70
- optimal feedback algorithm 186
- optimal gain matrix obtaining the 162–3
- optimisation 179–93
 - building blocks of 179–86
 - construction of time-optimal controls 192–3
 - development of algorithms 191
 - problems 179–85
- orthogonality 197
- oscillating and oscillating approximation of curves 199
- overtraining 230
 - illustrating phenomenon of 231

- parameter estimation,
 - methods/approaches/techniques for 64–6
- performance index 125

- planning 245
 - forecasting and prediction 164–6
- point, behaviour in region approximated at 198
- poles 167
 - cancellation 39
 - locations, meaning of 35–7
 - placement 38
 - and zeros of a transfer function 34
- Pontryagin's maximum principle 185
 - proof of 191
- power amplification obtained in hydro frequency control 96
- prediction
 - approaches to 165
 - by curve extrapolation 166
 - followed by control 28
 - physically based models for 166
- predictive control 166
- preprogrammed control 28
- probing controller, idea of 246
- process non-linearity
 - large signal problems 176
 - small signal problems 176
- project benefits 129

- quadratic cost functions 202
- quantitative feedback theory (QFT) 258
- quantitative insight into stabilisability and robust control 219

- rapid control development for a new batch process 244–5
- reachable regions in state space 189
- reasoning under uncertainty 245
- recursive network 232
- references 255–64
 - adaptive and model-based control 259
 - differential topology/differential geometry/differential algebra 261–2
 - distributed parameter systems 258
 - fuzzy logic and fuzzy control 259
 - general mathematics 260
 - genetic algorithms 259
 - genetic programming and other parallel evolutionary search methods 259
 - H_p spaces and H_∞ (robust) control 258
 - intelligent and learning systems 259
 - library books 255
 - neural networks and support vector methods 258
 - non-linear systems 257
 - operator theory and functional analysis applied to linear control 262–3
 - optimisation 257
 - ordinary differential equations 261
 - sliding mode control 257
 - state estimation 257
 - stochastic aspects of control 260
 - theory of equations 262
 - useful tables 264
- relay control systems 112, 169
- relay controller 111
- requirements
 - capture 16–17
 - needed for successful control three 4
 - of telephony 249
- resonant frequencies from pole-zero diagram, calculation of 43
- review of development of control theory and emergence of artificial intelligence (AI) techniques 249–54
- Riccati equation 186
- rivals to neural networks 234
- robustness against changes
 - control loop 96–8
 - in the process 96–8
- root loci 46, 155, 167
 - diagram 40
 - technique 39
- Routh array test 88
- Routh–Hurwitz criterion 88
 - see also* Hurwitz Routh
- Runge–Kutta
 - approach to numerical solution 133
 - methods 154

- sample cost calculations 126
- Saturn's rings 85
- scalar valued function 181
- science models 62
- sector bound methods 170
- self-learning 244
- self-reconfigurability 244
- self-tuning controller fitting into closed loop with process 121
- sequence
 - of objectives involved in typical control project 16
 - spaces P 221
- servomechanism
 - papillary 70
 - process control and aerospace applications 47

- Shannon's theorem 102
 - single feedback control in process changes,
 - robustness of 98
 - single-input single-output linear system
 - 138, 205
 - sinusoidal analysis 51, 54, 169
 - software engineering 15
 - spaces, hierarchy of 220
 - spatial discretisation 198
 - spiral
 - expanding 173
 - shrinking 173
 - stability 83
 - aspects of system models 87
 - for control systems quantification 86–8
 - of feedback loop, guaranteed 204
 - limited information 167
 - margins 88
 - need for 51
 - as property of system 157
 - tests for non-linear systems 89
 - theory 84, 250
 - milestones in 86
 - stabilisers of ship 207
 - stable oscillators 169
 - state estimation 159–66
 - applications 159
 - state estimator 186
 - working 160
 - state feedback
 - application of 159
 - use of 159
 - state plane 173
 - diagram for second-order system with
 - complex eigenvalues 174
 - state space
 - equation time solution of 139–41
 - form 138
 - representations 138–9
 - steel strip rolling mill rolls 218
 - step response, information from first
 - part 120
 - stepwise increases in control signal 24
 - stick-slip motion 169
 - strip rolling mill, characteristics
 - of 207
 - structure of system 1
 - support vector machines (SVMs) 234
 - Swedish hydro generating plant 95
 - switched systems 169
 - synthesis, limits and constraints on 98
 - systems
 - behaviour
 - questions related to 16
 - understanding from knowledge of pole
 - and zero locations in complex plane
 - 34–7
 - boundary 1
 - characterised by behaviour at point in
 - space 195–6
 - design 17
 - beginnings of methodology for 17
 - synthesis methods 167
 - top-down 16
 - model using inversely to synthesise
 - actions 12
 - performance, questions related to 16
 - response to arbitrary stimulus 2
 - simplification through block manipulation
 - 32–3
 - that are difficult to control 98–100, 101–2
 - transfer function 55–6
- Takahashi's algorithm 151–2
- Tartaglia's method 87
- Taylor series 108, 183, 199
 - approximation 133
 - expansions 199
- theoretical limitations on performance 102
 - sensitivity functions and their
 - interrelation 102
- thought experiments, effectiveness of 79
- three-term controllers 53, 113, 115
 - choosing three coefficients of 114
- throughput, matching to market
 - conditions 129
- time
 - optimal control 186–8
 - geometric view 188–91
 - optimality 191
 - varying processes 163, 164
- Toricelli, theorem of 76
- total internal stability and design for
 - disturbance rejection 206–10
- trajectories of stable system 173
 - crossing contour of V function 93
- transfer function
 - concept of 31–2
 - by cross-correlation determination of 43
 - obtained from differential equation 33–4
 - of process, obtaining 40–2
 - representations 137
 - transform methods 167
- transient response curve 40–2
- transition matrix 141
- trans-US telephone cable 122
- tuning procedure, on-line 121

- uncontrollable system 143
- unit step response 53
 - design based on 52–3
- universal constants 64
- universality of control theory 4
- unstable pole
 - cancellation by matching zero in the controller 99–100
 - shifting by feedback 100
- unstable systems 98–100
- upper limits on performance 124
- user
 - requirements converting into control specification 123–4
 - view of the control system 9
- V function contour 92, 93
- value of integral term in removing any constant error, illustration of the 113
- van der Pol equation 169
- velocity profile 187
- verification using reverse engineering, place of 18
- water wheel 76–9
 - modelling 77
- Watt, James 250
 - governor for steam engines 250
- Weierstrass' theorem 180, 234
- XOR function 228, 229
- Ziegler–Nichols
 - equations 116
 - methods 53
 - rules 116, 150